



JOHN DEERE

OPERATOR'S MANUAL

Tractor Mounted Sprayer
15 Gallon Sprayer

LP53283
Supplier ST43893
04/04/2022
English

Introduction

Using Your Operator's Manual

Read this entire operator's manual, especially the safety information, before operating. This manual is an important part of your machine. Keep all manuals in a convenient location so they can be accessed easily.

Use the safety and operating information in the attachment operator's manual, along with the machine operator's manual, to operate and service the attachment safely and correctly.

If your attachment manual has a section called Preparing the Machine, it means that you will have to do something to your tractor or vehicle before you can install the attachment.

The Assembly and Installation sections of this manual provide information to assemble and install the attachment to your tractor or vehicle. Use the Service section to make any needed adjustments and routine service to your attachment.

If you have any questions or concerns with the assembly, installation, or operation of this attachment, see your local John Deere dealer.

Warranty information on this John Deere attachment can be found in the warranty statement included in this manual.

Table of Contents

Introduction	2
Product Identification	2
Safety Labels	3
Safety	4
Assembly	8
Installing	10
Preparing Vehicle	10
Removing and Storage	11
Operating	12
Service	15
Troubleshooting	17
Specifications	18
Getting Quality Service	18
Warranty	18

Product Identification

Product Compatibility

The 15 Gallon Sprayer is designed for use with John Deere 100 Series and S240 Lawn Tractors.

Contact your John Deere dealer for specific tractor compatibility information.

Original instructions. All information, illustrations and specifications in this manual are based on the latest information available at the time of publication.

The right is reserved to make changes at any time without notice.

Safety Labels

Safety Label Locations

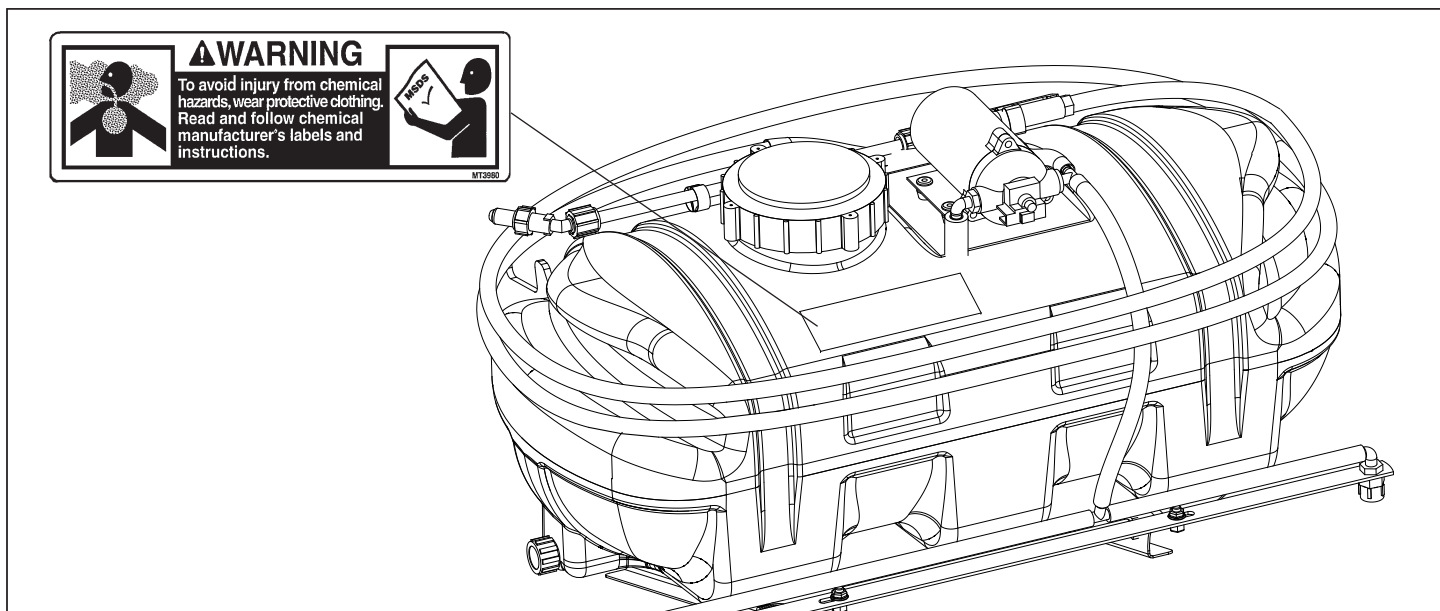

Understanding The Machine Safety Labels



The machine safety labels shown in this section are placed in important areas on your machine to draw attention to potential safety hazards.

On your machine safety labels, the words **DANGER**, **WARNING**, and **CAUTION** are used with this safety-alert symbol. **DANGER** identifies the most serious hazards.

The operator's manual also explains any potential safety hazards whenever necessary in special safety messages that are identified with the word, **CAUTION**, and the safety-alert symbol.

Replace missing or damaged safety labels. Use this operator's manual for correct safety label placement. There can be more safety information contained on parts and components sourced from suppliers that is not reproduced in this operator's manual.

French or Spanish Safety Labels and Operator's Manual

Operator's manuals and safety labels with content in French or Spanish are available for this machine through authorized John Deere dealers.

See your John Deere dealer. To avoid injury from chemical hazards, wear protective clothing. Read and follow chemical manufacturer's labels and instructions.



Safety

Read Safety in Machine Operator's Manual

Read the general safety operating precautions in your machine operator's manual for additional safety information.

Operating Safely

- Read the machine and attachment operator's manual carefully. Be thoroughly familiar with the controls and the proper use of the equipment. Know how to stop the machine and disengage the controls quickly.
- Do not let children or an untrained person operate machine.
- Make any necessary adjustments before you operate. Never attempt to make any adjustments while the engine is running, unless if recommended in adjustment procedure.
- Take all possible precautions when leaving the machine unattended. Shut off the engine before making any repairs, adjustments, or inspections. Lower the attachment, lock the parking brake, stop the engine, and remove the key.
- Look behind machine before you back up. Back up carefully.
- Do not let anyone, especially children, ride on machine or attachment. Riders are subject to injury such as being struck by foreign objects and being thrown off. Riders may also obstruct the operator's view, resulting in the machine being operated in an unsafe manner.
- Use only attachments and accessories approved by the manufacturer of this product.
- If the machine vibrates abnormally, stop the engine and check immediately for the cause. Vibration is generally a warning of trouble.
- Always refer to the Storage section of the operator's manual for important details if storing this product for a long period of time.

Operating Safely

- Keep people and pets out of the work area. Stop machine if anyone enters the area.
- If you hit an object, stop the machine and inspect it. Make repairs before you operate. Keep machine properly maintained and in good working order. Keep all shields and guards in place.
- Always inspect the sprayer completely before and after each use. Before pressurizing the system, check to be sure all fittings and hoses are tightly installed. Be sure guards and shields are in good condition and fastened in place. Make any necessary adjustments before you operate.
- Never use the sprayer during windy conditions.
- Always release pressure in the system before filling, cleaning or servicing the sprayer.
- Do not put nozzle tip or other sprayer parts to your lips to blow out dirt.

Parking Safely

1. Stop vehicle on a level surface, not on a slope.
2. Lock park brake.
3. Stop engine.
4. Remove key.
5. Before you leave the operator's seat, wait for engine and all moving parts to stop.

Safety

Mix and Handle Chemicals Safely

- It is best to wear full cover clothing and always wear protective goggles and rubber gloves to protect yourself while handling chemicals.
- Follow instructions on chemical container labels.
- Open all chemical containers carefully, using proper tools.
- Open, pour, weigh and mix chemicals in a well-ventilated area.
- Reserve all equipment used for the application of chemicals exclusively for that purpose.
- Prohibit all smoking, drinking and eating food in chemical-handling area.
- It is a good practice to take a soapy shower immediately after the using the sprayer to apply chemicals.
- Wash all clothing worn when using chemicals separately in the laundry after spraying is completed.

Read Chemical Container Label

- Chemicals can be dangerous. Improper selection or use can injure persons, animals, plants, soils or other property. Select the right chemical for the job and handle and apply with care.
- Read the instructions, precautions, and warnings on the container label before opening. Use the product strictly according to label directions for specific applications, in the amounts specified, at the times specified and only when needed.
- Keep the container closed tightly except when preparing the mix.
- Do not remove labels from chemical containers.
- Store all chemicals in their original containers.
- Do not mix chemicals unless stated on the container label.
- Store chemicals when not in use according to the container label.

Handle Chemical Products Safely

- Direct exposure to hazardous chemicals can cause serious injury. Potentially hazardous chemicals used with John Deere equipment include pesticides, herbicides and fungicides.
- A Material Safety Data Sheet (MSDS) provides specific details on chemical products: physical and health hazards, safety procedures, and emergency response techniques.
- The MSDS should be obtained from the chemical dealer at the time of the chemical purchase.
- Check the MSDS before beginning any job using a hazardous chemical. Know exactly what the risks are and how to do the job safely. Always wear recommended personal protection equipment.

Practice Safe Maintenance

- Only qualified, trained adults should service this machine.
- Understand service procedure before doing work. Keep area clean and dry.
- Do not operate the engine in a confined space where dangerous carbon monoxide fumes can collect.
- Never lubricate, service or adjust the machine or attachment while it is moving. Keep safety devices in place and in working condition. Keep hardware tight.
- Keep hands, feet, clothing, jewelry, and long hair away from any moving parts, to prevent them from getting caught.
- Lower any attachment completely to the ground or to an existing attachment mechanical stop before servicing the attachment. Disengage all power and stop the engine. Lock park brake and remove the key. Let machine cool.
- Disconnect battery or remove spark plug wire (for gasoline engines) before making any repairs.

Safety

Practice Safe Maintenance

- Before servicing machine or attachment, carefully release pressure from any components with stored energy, such as hydraulic components and springs.
- Release hydraulic pressure by lowering attachment or cutting units to the ground or to a mechanical stop and move hydraulic control levers.
- Securely support any machine or attachment elements that must be raised for service work. Use jack stands or lock service latches to support components when needed.
- Never run engine unless park brake is locked.
- Keep all parts in good condition and properly installed. Fix damage immediately. Replace worn or broken parts. Replace all worn or damaged safety and instruction decals.
- Check all hardware at frequent intervals to be sure the equipment is in safe working condition.
- Do not modify machine or safety devices. Unauthorized modifications to the machine or attachment may impair its function and safety.

Wear Appropriate Clothing



- Wear close fitting clothing and safety equipment appropriate for the job.
- Certain operating conditions may dictate that the operator and any passenger wear appropriate safety equipment while operating the vehicle. Be prepared for any existing and potential conditions before operating machine.
- Local safety or insurance regulations may require additional safety equipment such as eye protection or a hard hat.
- Always wear substantial footwear and long trousers. Do not operate the equipment when barefoot or wearing open sandals.
- Wear proper clothing and safety equipment while handling chemicals or using the sprayer. Refer to the MSDS for the chemicals being used to be sure the proper personal protection equipment is being used.



Avoid High Pressure Fluids

- Hydraulic hoses and lines can fail due to physical damage, kinks, age, and exposure. Check hoses and lines regularly. Replace damaged hoses and lines.
- Hydraulic fluid connections can loosen due to physical damage and vibration. Check connections regularly. Tighten loose connections.
- Escaping fluid under pressure can penetrate the skin causing serious injury. Avoid the hazard by relieving pressure before disconnecting hydraulic or other lines. Tighten all connections before applying pressure.
- Search for leaks with a piece of cardboard. Protect hands and body from high pressure fluids.
- If an accident occurs, see a doctor immediately. Any fluid injected into the skin must be surgically removed within a few hours or gangrene may result.

Doctors unfamiliar with this type of injury should reference a knowledgeable medical source.

Such information is available from Deere & Company Medical Department in Moline, Illinois, U.S.A.

Information may be obtained in the United States and Canada only by calling 1-800-822-8262.

Safety

Dispose of Chemicals Properly

- Proper disposal of excess spray material is very important. If you have excess tank solution, it is best to dilute it with water and apply it to the area you previously treated.
- Never dump solution into a drain or near a lake or stream.
- Chemicals containers should be triple-rinsed, with the rinse water added to the sprayer tank. Do not burn empty chemical containers. Dispose of containers at recycling centers.

Handling Waste Product and Chemicals

- Waste products, such as, used oil, fuel, coolant, brake fluid, and batteries, can harm the environment and people:
- Do not use beverage containers for waste fluids - someone may drink from them.
- See your local Recycling Center or authorized dealer to learn how to recycle or get rid of waste products.
- A Material Safety Data Sheet (MSDS) provides specific details on chemical products: physical and health hazards, safety procedures, and emergency response techniques. The seller of the chemical products used with your machine is responsible for providing the MSDS for that product.

Assembly

Assembly Parts List

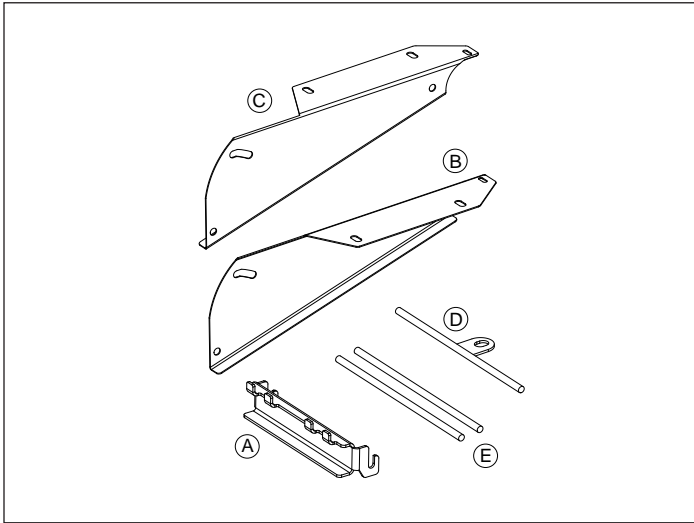

Parts List

Description	Qty
Mounting Bracket (A)	1
Tank Support, Right (B)	1
Tank Support, Left (C)	1
Rod with Drawbar (D)	1
Rod, 1/2-in (E)	2
Tank Assembly	1
Boom Assembly	1

Hardware Bag

Description	Qty.
Flange Head Bolt, 5/16 x 5/8	4
Truss Head Bolt, 5/16 x 1	2
Flat Washer, 3/8	4
Flange Nut, 5/16	2
Lockwasher, 1/2	4
Flange Nut, 1/2	4
Hex Nut, 1/2	8
Drawbar Pin, 3/4	1
Clip Pin	1
Wire Clip, Plastic	5
Wire Harness	1
Tie Wrap	2

Assembly Tank

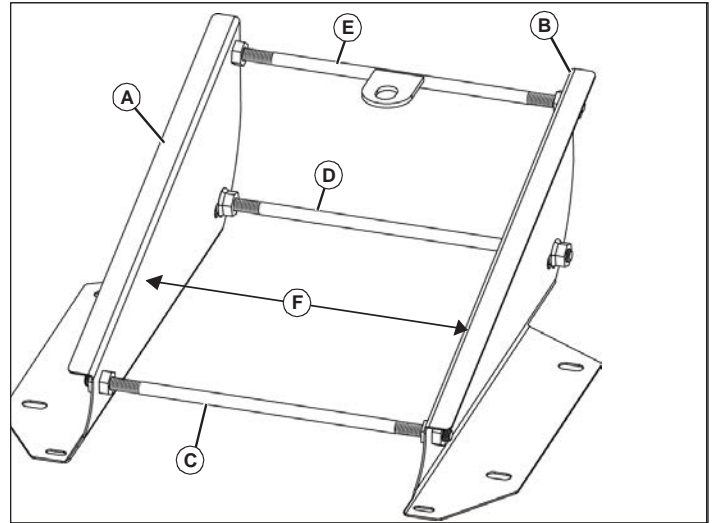

NOTE: Distance from inside face to face of tank supports must be 13-1/2 inches (E), and can be adjusted with 1/2-in. nuts.

1. Position left and right tank supports (A and B) as shown.
2. Install one 1/2-in. rod (C) in rear position with four 1/2-in. hex nuts and two 1/2-in. lockwashers.
3. Install one 1/2-in. rod (D) in front slotted position with four 1/2-in. flange nuts.
4. Install 1/2-in. rod with drawbar (E) in front top with four 1/2-in. hex nuts and two 1/2-in. lockwashers.
5. Adjust 1/2-in. nuts to obtain distance of 13-1/2 inches (F) from inside face to face of tank supports.

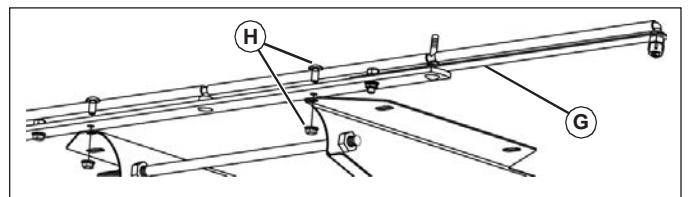

6. Install boom assembly (G) to frame with two 5/16 truss head bolts and 5/16 flange nuts (H).

Assembly

Assembly Tank

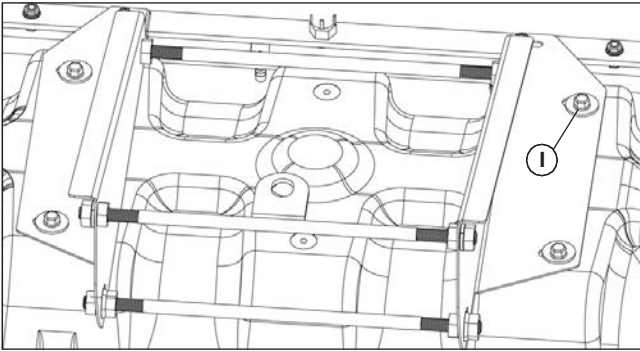

7. Secure tank assembly to left and right frames with four 3/8 flat washers and 5/16 x 5/8 flange bolts (I).
8. Position tank with spray wand to front. Tighten bolts to 14 N•m (10 lb-ft).

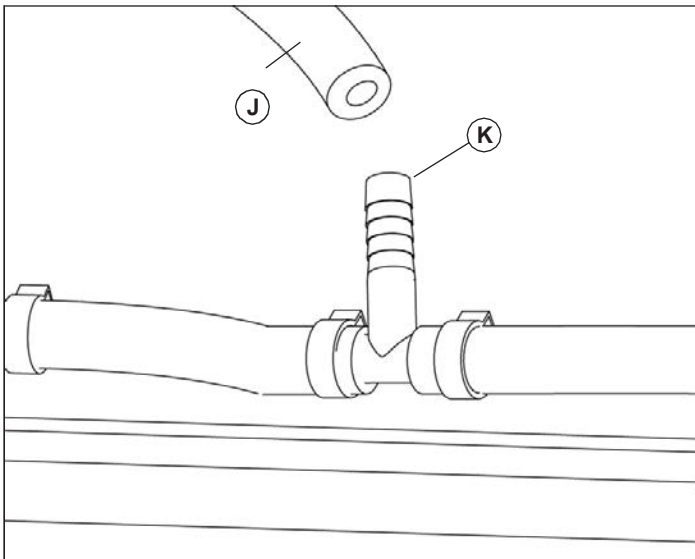

9. Connect boom hose (J) on tank assembly to tee fitting (K) on boom assembly (no clamp required).

Install Anchor Mount

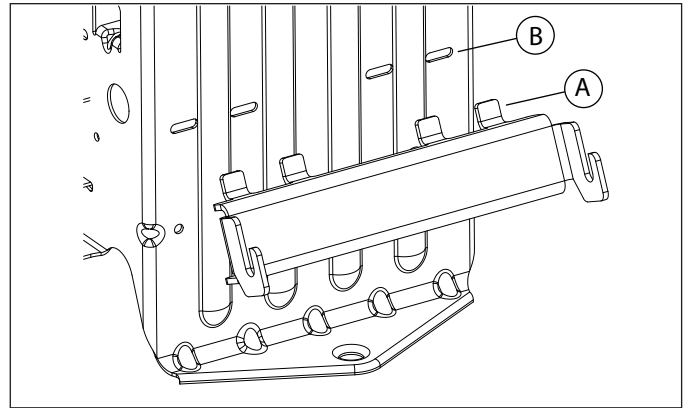

1. Tilt the anchor bracket slightly and install the four tabs (A) into the four slots (B) on the rear frame of the tractor.

Install Sprayer

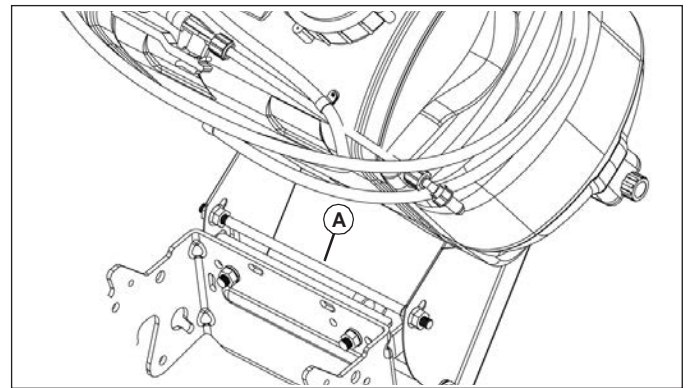

Angle sprayer and place top rod (A) into holding slots in anchor bracket.

1. Angle sprayer and place top rod (A) into holding slots in anchor bracket.

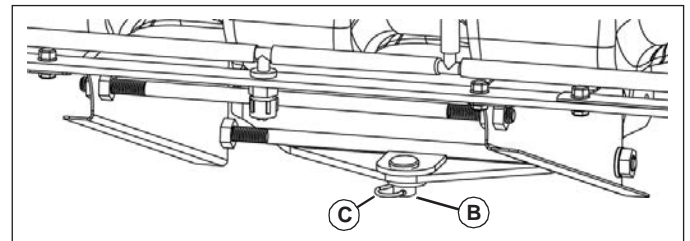

2. Place 3/4-in. drilled pin (B) through tractor hitch and slot of drawbar. Insert spring clip pin (C) to lock assembly in place.
3. Adjust rod positions in left and right frame slots to level sprayer.

Installing

Install Harness

IMPORTANT: Avoid damage! To help prevent electrical spark, install red wire to the positive (+) battery terminal first. Then install black wire to negative (-) battery terminal.

To prevent damage to wiring, make sure hood does not close on wires or connectors.

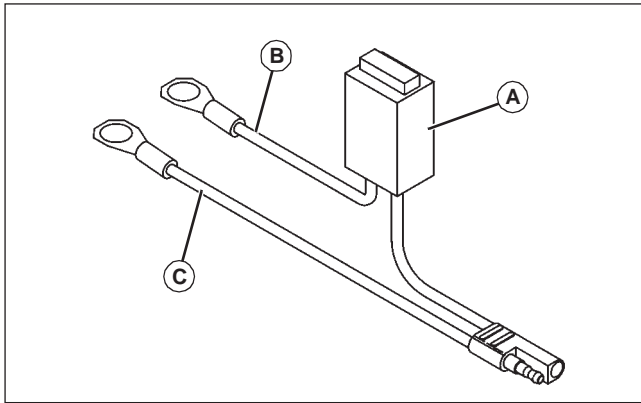

1. Fuse holder (A) should contain a 15 A / 12 V fuse. Make sure fuse filament is not broken.
2. Open hood. If battery is mounted low and behind the grille, carefully unsnap top of grille to provide access to battery terminals.
3. Remove nut from positive (+) battery cable clamp. Install red lead (B) through the rubber boot and then onto the clamp bolt. Tighten nut completely. Make sure that the rubber boot (D) is able to cover all the terminal connections.



4. Remove nut from negative (-) battery cable clamp. Install black lead (C) onto clamp bolt. Lay the wire. Install and tighten nut completely.

Install Wire Harness Extension

1. Open vehicle hood.
2. Connect wire harness extension to pump leads.
3. Route wire harness extension from the pump to the battery using the wire clips to secure the harness.

IMPORTANT: Avoid damage! Avoid damage to wiring. Make sure hood does not close on wiring harnesses. Keep wiring harnesses away from all moving parts and hot surfaces.

4. Close hood.

Install Wiring Clips

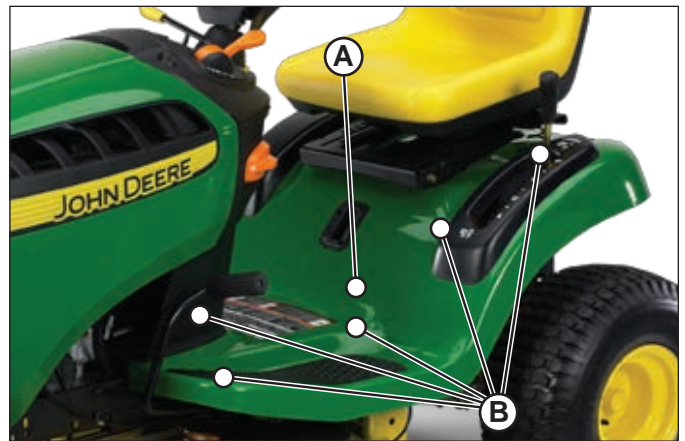

1. Clean foot rest side panel (A) at left side of machine with mild detergent or isopropyl alcohol. Dry thoroughly.
2. Attach wire clip to 5 locations (B) so the sprayer wiring harness will not interfere with the deck height adjustments, operators seat, or foot area.

Preparing Vehicle

Machine Requirements

Make sure machine tire pressure is correct for attachment weight. (See your machine operator's manual for the correct pressure.)

Your machine requires the following:

12-Volt battery and alternator

Ballast



CAUTION: Avoid injury! Machine can become unstable when operating with attachment. Ballast is required when the attachment is installed.

All machines using this sprayer require attachment of the Mid-mount mower for ballast.

Removing and Storing

Removing Sprayer

1. Park machine safely. (See Parking Safely in the Safety section.)



CAUTION: Avoid injury! To avoid chemical injury:

- Wear protective clothes, gloves and goggles when handling sprayer.
- Do not store sprayer with chemicals in tank.
- If spray comes in contact with your body, immediately follow directions on chemical container pertaining to spray material.

2. Empty the sprayer tank.

NOTE: Battery harness with fuse should not be removed.

3. Disconnect main wiring harness only. Leave all other harnesses installed on tractor.
4. Roll up main harness and store with sprayer.
5. Remove 3/4 in. pin (A).

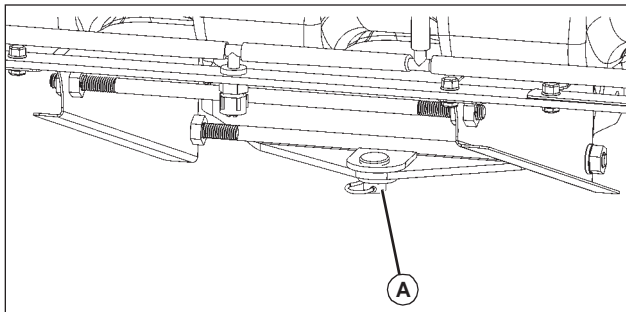

6. Lift sprayer (B) off tractor anchor (C).

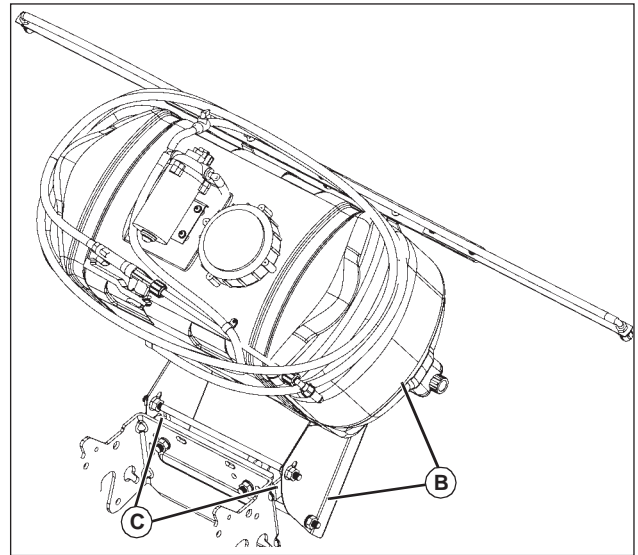

7. Tilt the anchor bracket slightly and remove the four tabs (D) from the four slots (E) on the rear frame of the tractor. Store the bracket with the sprayer.

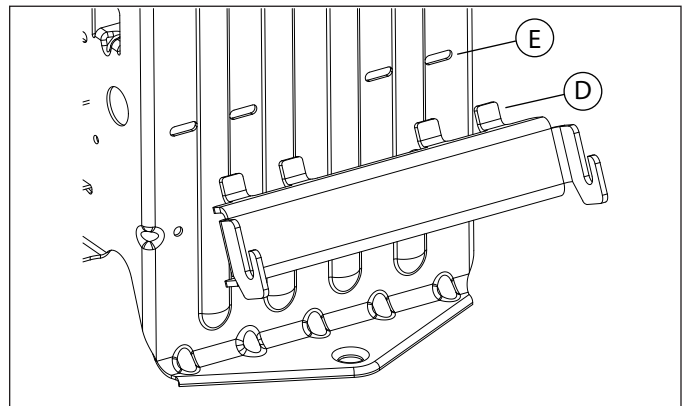

Operating

Store Sprayer Safely



CAUTION: Avoid injury! To avoid chemical injury:

- Wear protective clothes, gloves and goggles when handling sprayer.
- Do not store sprayer with chemicals in tank.
- If spray comes in contact with your body, immediately follow directions on chemical container pertaining to spray material.

1. Pump all spray material from tank. (See Dispose of Chemicals Properly in the SAFETY section.)
2. Rinse tank, pump, spray wand and all hoses thoroughly with fresh clean water.
3. Repeat step 2 several times.
4. Wipe out sump with a clean cloth or paper towel.
5. Drain hoses and pump filter.
6. Check sprayer for worn or damaged parts. Replace parts as needed.
7. Tighten loose hardware.
8. Store sprayer in a place where it will not freeze.

Operating

Filling Sprayer Tank



CAUTION: Avoid injury! Chemicals can be dangerous. Avoid injury to operator or bystanders:

- Read chemical container label for mixing and handling instructions. A Material Safety Data Sheet (MSDS) should be supplied by the chemical dealer and provides proper safety information.
- Wear proper clothing and safety equipment while handling or applying spray chemicals.
- Wear a full covering of clothing, protective goggles and rubber gloves.
- Prohibit all smoking, drinking, and eating around chemicals.
- When filling tank, never allow end of water hose to contact chemical mixture.

IMPORTANT: Avoid damage! Clean any spills immediately with clean water prior to operating the sprayer.

1. Clean area around tank filler cap to prevent tank contamination.
2. Remove tank filler cap and fill tank.
3. Install tank filler cap.

Draining and Cleaning Sprayer Tank

IMPORTANT: Avoid damage!

- Proper disposal of excess spray is very important. Dilute it with water and apply it to area previously treated.
- Never dump excess into a storm drain or near a lake or stream.

1. The preferred method of cleaning is to dilute remaining material with water and apply it to the area previously treated:
 - If excess material remains, remove drain cap and empty remaining material into an appropriate container for reuse or for disposal according to local regulations or as specified in the manufacturer's label.

NOTE: Be sure to visibly label the container contents for safety.

4. Spray all inside surfaces of tank with low pressure garden hose to remove any remaining solution. Replace the drain cap and run clean water through the pump, hoses and boom applying those contaminated contents on previously treated area.
5. Rinse outside of sprayer tank thoroughly with fresh clean water. Rinse several times to make sure sprayer tank is clean and free of chemicals.
6. Once the tank is empty, wipe out inside of sprayer tank with a clean cloth or paper towel.
7. Install drain cap and filler cap.

Operating

Operating Spray Wand

NOTE: It is not recommended to use wand while operating the machine. Turn machine on for wand use, but do not maneuver machine unless wand and hose are in normal storage position on the tank.

- Turn shut-off valve lever perpendicular to hose.

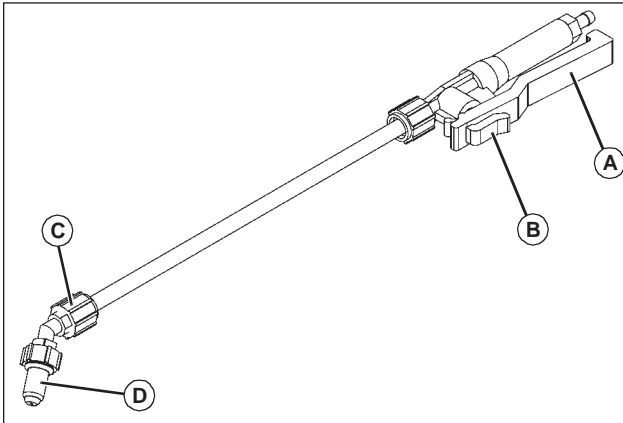

- Squeeze handle (A) to spray.
 - Push lock (B) forward to lock handle into the on position.
- Adjust nozzle:
 - Nozzle Angle - Loosen locknut (C). Turn nozzle (D) as desired and tighten locknut.
 - Nozzle Spray Pattern - To change spray pattern, tighten or loosen nozzle (D) as desired.

Spraying Tips

- Do not let sprayer run in one spot.
- Do not over spray when you use weed killers.
- Liquid spray material is recommended. Sprayer does not agitate wettable powders.
- Timely applications of a smaller dosage are better than large applications.
- Turn sprayer off during turns to avoid double spraying.
- Fill sprayer where spills cannot harm grass.
- Follow manufacturer's recommendations for application of specific chemicals.
- Stop sprayer when tank is empty.
- Always purge air from spray wand at start of spraying session.

Checking Machine Ground Speed

- Drive vehicle and sprayer (half-full is optimal) across a measured distance at a constant speed. There can be no change in speed while measuring time. Speed should be a comfortable speed for spraying.
- Measure the amount of time (in seconds) it takes to travel the measured distance.
- Speed can be found by entering data into the equation: $\text{speed (mph)} = \text{distance (ft)} \times 60 / \text{time (sec)} \times 88$, or by consulting the following table. It is helpful to note throttle location, gear and/or RPMs in order to maintain accuracy.

Speed in mph	Time (sec) required to travel a distance of:	
	200 ft	300 ft
1.0	136	205
1.5	91	136
2.0	68	102
2.5	55	82
3.0	45	68
3.5	39	58
4.0	34	51
4.5	30	45
5.0	27	41
5.5	25	37
6.0	23	34
6.5	21	31
7.0	19	29

Operating

General Spraying Information

Sprayer Application:

The sprayer operates at a fixed pressure through the boom and spray wand. Although the pressure can be adjusted to the boom by partially opening the boom control valve, it is recommended that the valve is operated in full open position. Use the chart below to select your desired speed and application rate.

GPA (gallons per acre per nozzle)					
Model	2 mph	3 mph	4 mph	5 mph	6 mph
Mounted	54.5	36.3	27.2	21.8	18.2
Gallons per 1000 sq ft per nozzle					
Model	2 mph	3 mph	4 mph	5 mph	6 mph
Mounted	1.25	0.83	0.63	0.50	0.42

Standard Hand Wand			
Pressure	Nozzle	GPM (cone)	GPM (stream)
80 psi	#18	0.4	1.25
Sprayer Capacity		Approximate Spray Time in Minutes	
25		62.5	20
15		37.5	12

Adjusting Spray Tips

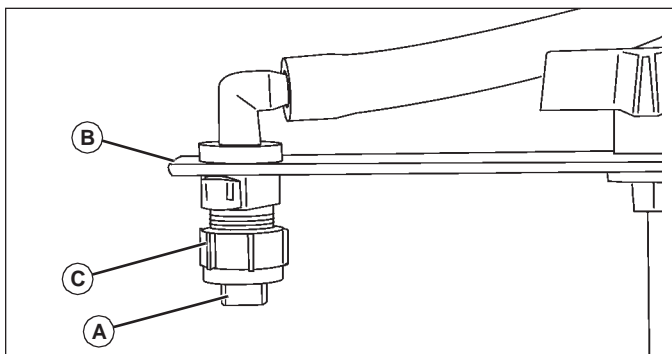

Check spray tips (A):

- Tips should be aligned with boom (B) as shown. If necessary, loosen spray tip cap nut (C). Align spray tip and tighten cap nut.

1. Test spray pattern with water on driveway or sidewalk, and adjust as necessary. Each spray tip pattern should spread out to the right and left sides, rather than to the front and back of the boom. There should be some spray overlap between each tip and the spray patterns should be consistent.

Starting and Stopping Sprayer

IMPORTANT: Avoid damage! Operate sprayer with transport vehicle running to avoid discharging the battery.

NOTE: The sprayer pump to battery hookup is a direct electrical connection. Shutting off the transport vehicle does not prevent operation of the sprayer pump. To avoid accidental spraying, disconnect the pump connection before leaving the sprayer.

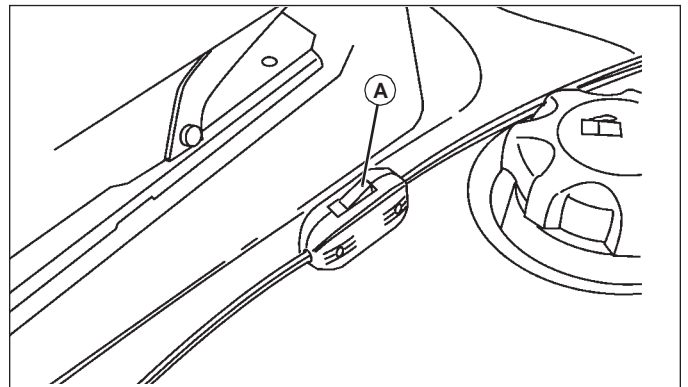

Push switch (A) to on or off position to start or stop sprayer.

Service

Selecting Spray Wand or Boom Nozzles

NOTE: Shut-off valve lever (A) has two positions:

- **ON POSITION** - Lever is parallel with hose. Pump flow is directed to the sprayer boom.
- **OFF POSITION** - Lever is perpendicular with hose. Pump flow is directed to the spray wand.

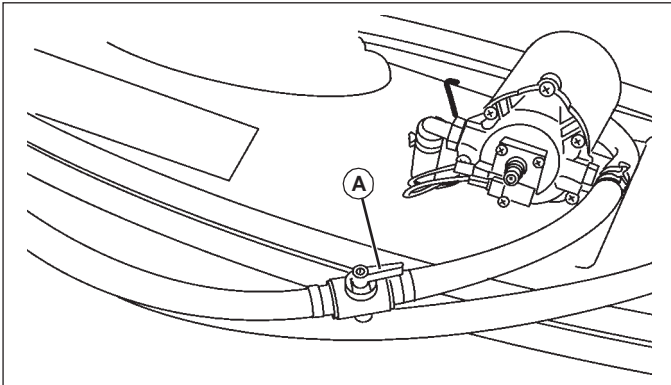

- To use spray wand: Turn lever (A) so that it is perpendicular with hose. You can now use the spray wand for spraying.
- To use sprayer boom: Turn lever (A) so that it is parallel with hose. Turn pump on and operate spray wand to remove all air from hose. After spray wand sprays liquid, turn pump off. Turn lever (A) so that it is parallel with hose. You can now use the boom nozzles for spraying.

Cleaning Spray Nozzle



CAUTION: Avoid injury! Do not put nozzle tip or other sprayer parts to your lips to blow out dirt. Use compressed air or clean water.

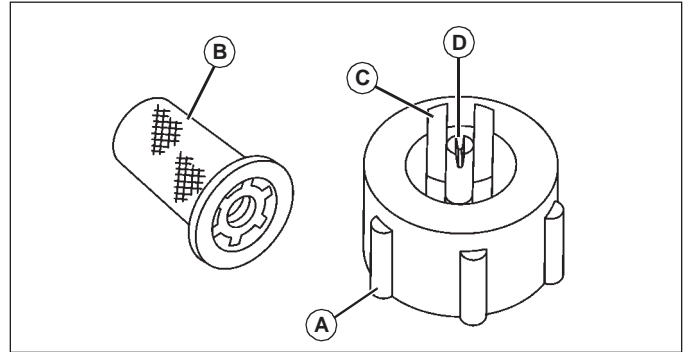

1. Remove spray nozzle (A) from sprayer.
2. Disassemble filter (B) and spray tip (C).

NOTE: Do not use a wire to clean opening (D) in spray tip.

3. Wash filter and spray tip in a non-flammable solvent.
4. Put spray tip in spray nozzle.
5. Put flat side of filter in spray nozzle.
6. Install assembly on sprayer and tighten nozzle.

Service

Cleaning Pump Suction Screen

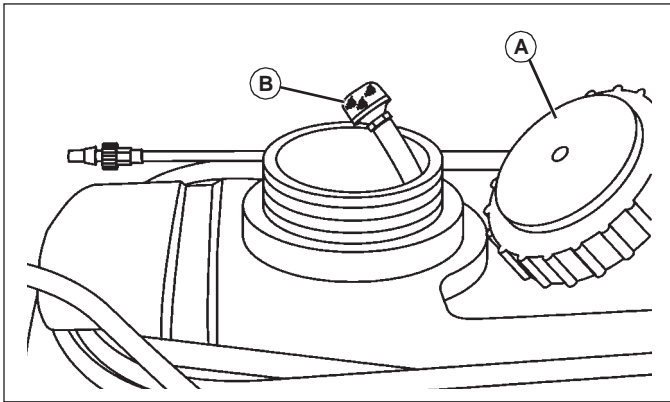

1. Remove tank cover (A).
2. Locate suction screen (B) inside sprayer tank.
3. If necessary, unscrew suction screen and clean with liquid detergent and warm water.
4. If suction screen was removed, install on suction hose and position in lowest depression inside tank.
5. Install and tighten tank cover.

Cleaning Spray Wand Nozzle

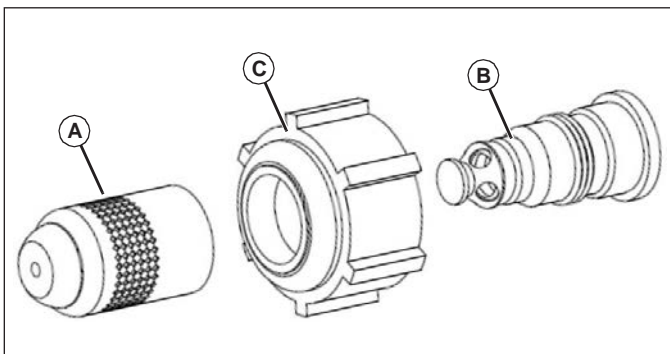

6. Unscrew nozzle (A) from spray tip (B).
7. Loosen nut (C) and remove spray tip (B) from angled fitting on wand.
8. Wash nozzle and spray tip with liquid detergent and warm water.
9. Inspect O-rings and replace as needed.
10. Slide nut Spray tip and install on angled fitting on wand.
11. Install nozzle on spray tip.

Changing Fuse

IMPORTANT: Avoid damage! The electrical system may be damaged if incorrect replacement fuses are used. Replace the bad fuse with a fuse of the same amp rating.

1. Open hood and locate battery harness and fuse holder that is attached to the battery.
2. Open cap on fuse holder and remove fuse.
3. Install new 15 amp fuse and reinstall cap.
4. Close hood.

Troubleshooting

Using Troubleshooting Chart

If you are experiencing a problem that is not listed in this chart, see your authorized dealer for service.

When you have checked all the possible causes listed and you are still experiencing the problem, see your authorized dealer.

IF	CHECK
Pump Loses Suction.	Clean Pump suction screen. Check tank fill level. Fill tank. Clean or replace pump. Check for loose pump fittings.
Pump Capacity Decreased.	Clean pump suction screen. Clean spray nozzle(s). Selection lever is not completely turned on, or is in the OFF position.
Poor Spray Pattern.	Clean spray nozzles. Adjust nozzle height. Align spray tips with boom.
Pump Does Not Work.	Check wiring connections. Check machine battery. Clean debris from pump. Check pump switch. Check pump motor. Check fuse on 12 volt plug adapter harness.

Specifications

Specifications

Model 15 Gallon Sprayer	
Tank Capacity	57 L (15 gallon)
Pump Type	Electric Motor and Diaphragm
Pump Manufacturer	Deere
Current Draw	7 amp
Fuse	15 amp
System Pressure	689 kPa (100psi)
Spray Rate	8.3 L/min (2.2 gal/min)
Suction Hose Strainer	Stainless Steel
Spray Tip Material	Plastic
Spray Wand Material	Plastic
Nozzle Tip Height	43cm (17 in)
Spraying Width	152 cm (60 in)
Empty Weight	13 kg (130 lb)
Full Weight	71 kg (157 lb)

Getting Quality Service

John Deere Quality Continues with Quality Service

John Deere provides a process to handle your questions or problems, should they arise, to ensure that product quality continues with quality parts and service support.

Follow the steps below to get answers to any questions you may have about your product.

1. Refer to your attachment and machine operator manuals.
2. In North America or Canada, call John Deere Special Services at 1-800-448-9282 and provide product serial number (if available) and model number.

Warranty:

Limited Warranty for New John Deere Licensed Products

Agri-Fab's sprayers are guaranteed to be free from defects in material and workmanship from the date of purchase for 2 years residential use, 6 months commercial use, provided that the purchaser properly assembles, installs, uses and maintains the products in accordance with this manual.

Purchaser's failure to adhere to such requirements will void the warranty. To the extent permitted by applicable law, all other warranties, representations, obligations and conditions, expressed or implied, including but not limited to implied warranties of merchantability, fitness for any particular purpose and non-infringement, are hereby disclaimed and excluded.

Any product which does not meet warranty shall, as purchaser's sole and exclusive remedy, be repaired or replaced by Agri-Fab. This warranty is non-transferable.

In addition, our warranty does not cover:

- Labor charges
- Loss or consequential, incidental or special damages of any kind

This page intentionally left blank

This page intentionally left blank