



JOHN DEERE

OPERATORS MANUAL
25 Gallon Tow Behind Sprayer

LP194791
Supplier 3-455
04/06/2026
English

Introduction

Using Your Operator's Manual

Read this entire operator's manual, especially the safety information, before operating.

This manual is an important part of your machine. Keep all manuals in a convenient location so they can be accessed easily.

Use the safety and operating information in the attachment operator's manual, along with the machine operator's manual, to operate and service the attachment safely and correctly.

If your attachment manual has a section called Preparing the Machine, it means that you will have to do something to your tractor or vehicle before you can install the attachment. The Assembly and Installation sections of this manual provide information to assemble and install the attachment to your tractor or vehicle. Use the Service section to make any needed adjustments and routine service to your attachment.

If you have any questions or concerns with the assembly, installation, or operation of this attachment, see your local John Deere dealer.

Table of Contents

Introduction	2
Product Compatibility	2
Safety Labels	4
Safety	5
Assembly - Parts in Carton	7
Assembly - Hardware Bag	8
Assembly	9
Installation	11
Preparing Vehicle.....	12
Operation.....	13
Removal and Storage	16
Service	17
Troubleshooting	18
Specifications	19
Parts Diagram.....	20
Good Quality Service.....	22
Warranty	23

Product Compatibility

This Sprayer is designed for use with John Deere riding lawn and garden products and John Deere utility vehicles.

Contact your John Deere dealer for specific machine compatibility information.

Original instructions. All information, illustrations and specifications in this manual are based on the latest information available at the time of publication.

The right is reserved to make changes at any time without notice.

NOTE: Retain these installation instructions with the machine operators manual.

Safety Labels

Safety Label Location

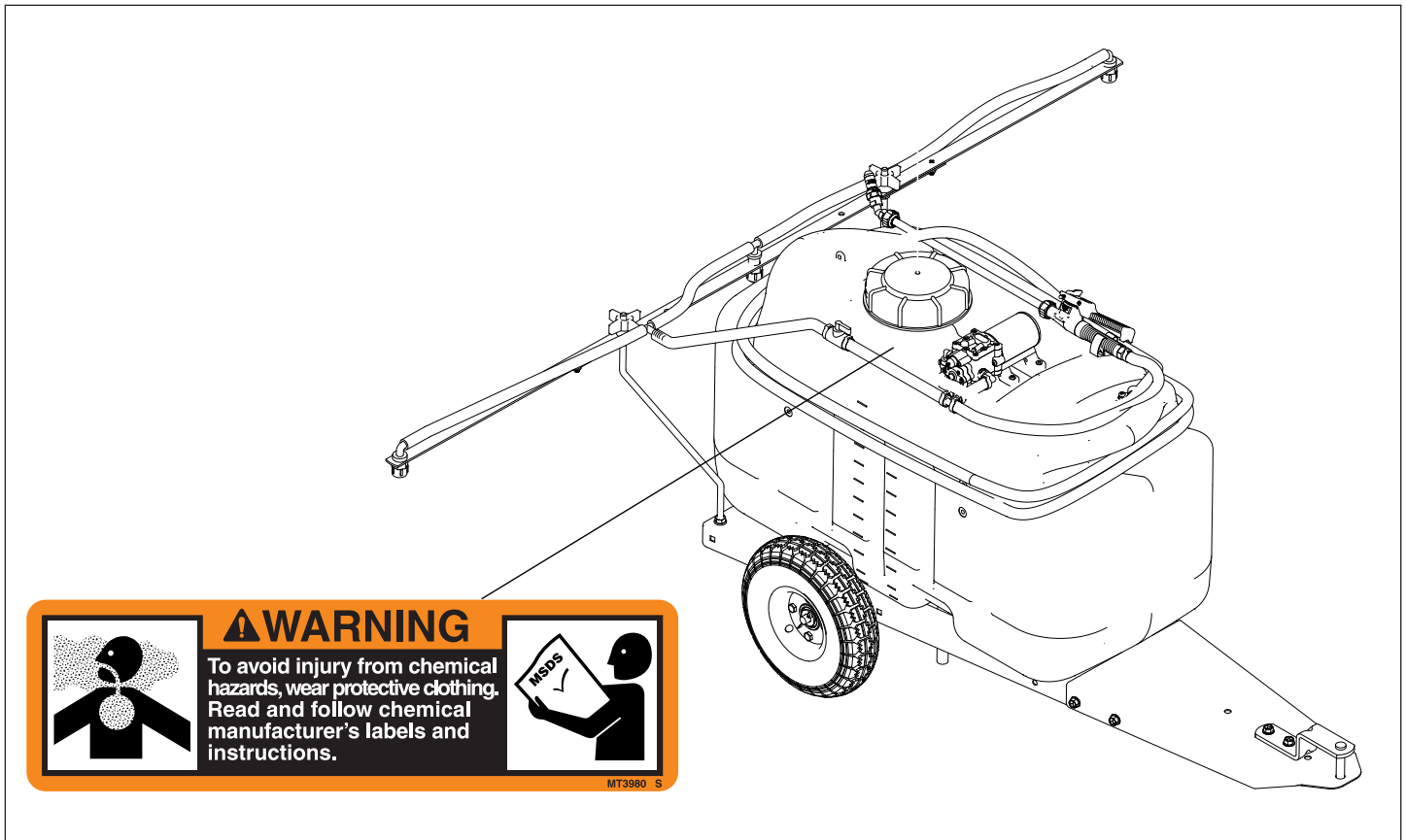

Understanding The Machine Safety Labels



The machine safety labels shown in this section are placed in important areas on your machine to draw attention to potential safety hazards.

On your machine safety labels, the words **DANGER**, **WARNING**, and **CAUTION** are used with this safety-alert symbol. **DANGER** identifies the most serious hazards.

The operator's manual also explains any potential safety hazards whenever necessary in special messages that are identified with the word, **CAUTION**, and the safety-alert symbol.

Replace missing or damaged safety labels. Use this operator's manual for correct safety label placement.

There can be more safety information contained on parts and components sourced from suppliers that is not reproduced in this operator's manual.

Warning

- To avoid injury from chemical hazards, wear protective clothing. Read and follow chemical manufacturer's labels and instructions.



Safety

Read Safety in Machine Operator's Manual

Read the general safety operating precautions in your machine operator's manual for additional safety information.

Operate Safely

- Read the machine and attachment operator's manual carefully. Be thoroughly familiar with the controls and the proper use of the equipment. Know how to stop the machine and disengage the controls quickly.
- Do not let children or an untrained person operate machine.
- Make any necessary adjustments before you operate. Never attempt to make any adjustments while the engine is running, unless if recommended in adjustment procedure.
- Take all possible precautions when leaving the machine unattended. Shut off the engine before making any repairs, adjustments, or inspections. Lower the attachment, lock the parking brake, stop the engine, and remove the key.
- Look behind machine before you back up. Back up carefully.
- Do not let anyone, especially children, ride on machine or attachment. Riders are subject to injury such as being struck by foreign objects and being thrown off. Riders may also obstruct the operator's view, resulting in the machine being operated in an unsafe manner.
- Use only attachments and accessories approved by the manufacturer of this product.
- If the machine vibrates abnormally, stop the engine and check immediately for the cause. Vibration is generally a warning of trouble.
- Always refer to the Storage section of the operator's manual for important details if storing this product for a long period of time.
- Keep people and pets out of the work area. Stop machine if anyone enters the area.
- If you hit an object, stop the machine and inspect it. Make repairs before you operate. Keep machine properly maintained and in good working order. Keep all shields and guards in place.
- Always inspect the sprayer completely before and after each use. Before pressurizing the system, check to be sure all fittings and hoses are tightly installed. Be sure guards and shields are in good condition and fastened in place. Make any necessary adjustments before you operate.
- Never use the sprayer during windy conditions.

- Always release pressure in the system before filling, cleaning or servicing the sprayer.
- Do not put nozzle tip or other sprayer parts to your lips to blow out dirt.
- Use compressed air.
- If the sprayer is mounted to the bed of a utility vehicle, never raise the bed with the sprayer installed. Empty the sprayer and remove it from the bed if you need to raise the bed for any reason.

Parking Safely

1. Stop vehicle on a level surface, not on a slope.
2. Lock park brake.
3. Stop engine.
4. Remove key.
5. Before you leave the operator's seat, wait for engine and all moving parts to stop.
6. Disconnect the negative battery cable or remove the spark plug wire (for gasoline engines) before servicing the machine.

Mix and Handle Chemicals Safely

- It is best to wear full cover clothing and always wear protective goggles and rubber gloves to protect yourself while handling chemicals.
- Follow instructions on chemical container labels.
- Open all chemical containers carefully, using proper tools.
- Open, pour, weigh and mix chemicals in a well-ventilated area.
- Reserve all equipment used for the application of chemicals exclusively for that purpose.
- Prohibit all smoking, drinking and eating food in chemical-handling area.
- It is a good practice to take a soapy shower immediately after the using the sprayer to apply chemicals.
- Wash all clothing worn when using chemicals separately in the laundry after spraying is completed.

Safety

Read Chemical Container Label

- Chemicals can be dangerous. Improper selection or use can injure persons, animals, plants, soils or other property. Select the right chemical for the job and handle and apply with care.
- Read the instructions, precautions, and warnings on the container label before opening. Use the product strictly according to label directions for specific applications, in the amounts specified, at the times specified and only when needed.
- Keep the container closed tightly except when preparing the mix.
- Do not remove labels from chemical containers. Store all chemicals in their original containers.
- Do not mix chemicals unless stated on the container label.
- Store chemicals when not in use according to the container label.

Handle Chemical Products Safely

- Direct exposure to hazardous chemicals can cause serious injury. Potentially hazardous chemicals used with John Deere equipment include pesticides, herbicides and fungicides.
- A Material Safety Data Sheet (MSDS) provides specific details on chemical products: physical and health hazards, safety procedures, and emergency response techniques.
- The MSDS should be obtained from the chemical dealer at the time of the chemical purchase.
- Check the MSDS before beginning any job using a hazardous chemical. Know exactly what the risks are and how to do the job safely. Always wear recommended personal protection equipment.

Towing Loads Safely

- Stopping distance increases with speed and weight of towed load. Travel slowly and allow extra time and distance to stop.
- Total towed weight must not exceed limits specified in towing vehicle operator's manual.
- Excessive towed load can cause loss of traction and loss of control on slopes. Reduce towed weight when operating on slopes.
- Never allow children or others in or on towed equipment.
- Use only approved hitches. Tow only with a machine that has a hitch designed for towing. Do not attach towed equipment except at the approved hitch point.

- Follow the manufacturer's recommendations for weight limits for towed equipment and towing on slopes. Use counterweights or wheel weights as described in the machine operator's manual.
- Do not turn sharply. Use additional caution when turning or operating under adverse surface conditions. Use care when reversing.
- Do not shift to neutral and coast downhill.

Keep Riders Off Towed Attachment

- Keep riders off of a towed attachment.
- Riders on a towed attachment are subject to injury, such as being struck by objects and being thrown off the attachment during sudden starts, stops and turns.
- Riders obstruct the operator's view, resulting in the attachment being used in an unsafe manner.
- Keep riders off of hitch bracket.

Avoid Injury From Drawbar

Before you disconnect an attachment from machine hitch plate:

- Unload attachment.
- Stop attachment on level ground.
- Stop machine engine.
- Lock machine park brake.
- Block attachment wheels.
- Make sure hands, feet or other body parts are not under drawbar.

Practice Safe Maintenance

- Only qualified, trained adults should service this machine.
- Understand service procedure before doing work. Keep area clean and dry.
- Do not operate the engine in a confined space where dangerous carbon monoxide fumes can collect.
- Never lubricate, service or adjust the machine or attachment while it is moving. Keep safety devices in place and in working condition. Keep hardware tight.
- Keep hands, feet, clothing, jewelry, and long hair away from any moving parts, to prevent them from getting caught.
- Lower any attachment completely to the ground or to an existing attachment mechanical stop before servicing the attachment. Disengage all power and stop the engine. Lock park brake and remove the key. Let machine cool.

Safety

- Disconnect battery or remove spark plug wire (for gasoline engines) before making any repairs.
- Before servicing machine or attachment, carefully release pressure from any components with stored energy, such as hydraulic components and springs.
- Release hydraulic pressure by lowering attachment or cutting units to the ground or to a mechanical stop and move hydraulic control levers.
- Securely support any machine or attachment elements that must be raised for service work. Use jack stands or lock service latches to support components when needed.
- Never run engine unless park brake is locked.
- Keep all parts in good condition and properly installed. Fix damage immediately. Replace worn or broken parts. Replace all worn or damaged safety and instruction decals.
- Check all hardware at frequent intervals to be sure the equipment is in safe working condition.
- Do not modify machine or safety devices. Unauthorized modifications to the machine or attachment may impair its function and safety.
- Death or serious injury will result from contact with overhead power lines. Keep clear of electrically charged power lines. Check the area before operating the spreader.

Wear Appropriate Clothing



Always wear eye protection when operating the machine.

Wear close fitting clothing and safety equipment appropriate for the job.

- While operating this machine, always wear substantial footwear and long trousers. Do not operate the equipment when barefoot or wearing open sandals.
- Wear a suitable protective device such as earplugs. Loud noise can cause impairment or loss of hearing.

Avoid High Pressure Fluids

- Hydraulic hoses and lines can fail due to physical damage, kinks, age, and exposure. Check hoses and lines regularly. Replace damaged hoses and lines.
- Hydraulic fluid connections can loosen due to physical damage and vibration. Check connections regularly. Tighten loose connections.
- Escaping fluid under pressure can penetrate the skin causing serious injury. Avoid the hazard by relieving pressure before disconnecting hydraulic or other lines.

Tighten all connections before applying pressure.

- Search for leaks with a piece of cardboard. Protect hands and body from high pressure fluids.
- If an accident occurs, see a doctor immediately. Any fluid injected into the skin must be surgically removed within a few hours or gangrene may result. Doctors unfamiliar with this type of injury should reference a knowledgeable medical source. Such information is available from Deere & Company Medical Department in Moline, Illinois, U.S.A. Information may be obtained in the United States and Canada only by calling 1-800-822-8262.

Dispose of Chemicals Properly

- Proper disposal of excess spray material is very important. If you have excess tank solution, it is best to dilute it with water and apply it to the area you previously treated.
- Never dump solution into a drain or near a lake or stream. Chemicals containers should be triple-rinsed, with the rinse water added to the sprayer tank. Do not burn empty chemical containers. Dispose of containers at recycling centers.

Handling Waste Product and Chemicals

- Waste products, such as, used oil, fuel, coolant, brake fluid, and batteries, can harm the environment and people:
- Do not use beverage containers for waste fluids - someone may drink from them.
- See your local Recycling Center or authorized dealer to learn how to **recycle or get rid of waste products**.
- A Material Safety Data Sheet (MSDS) provides specific details on chemical products: physical and health hazards, safety procedures, and emergency response techniques. The seller of the chemical products used with your machine is responsible for providing the MSDS for that product.

Assembly

Parts in Carton

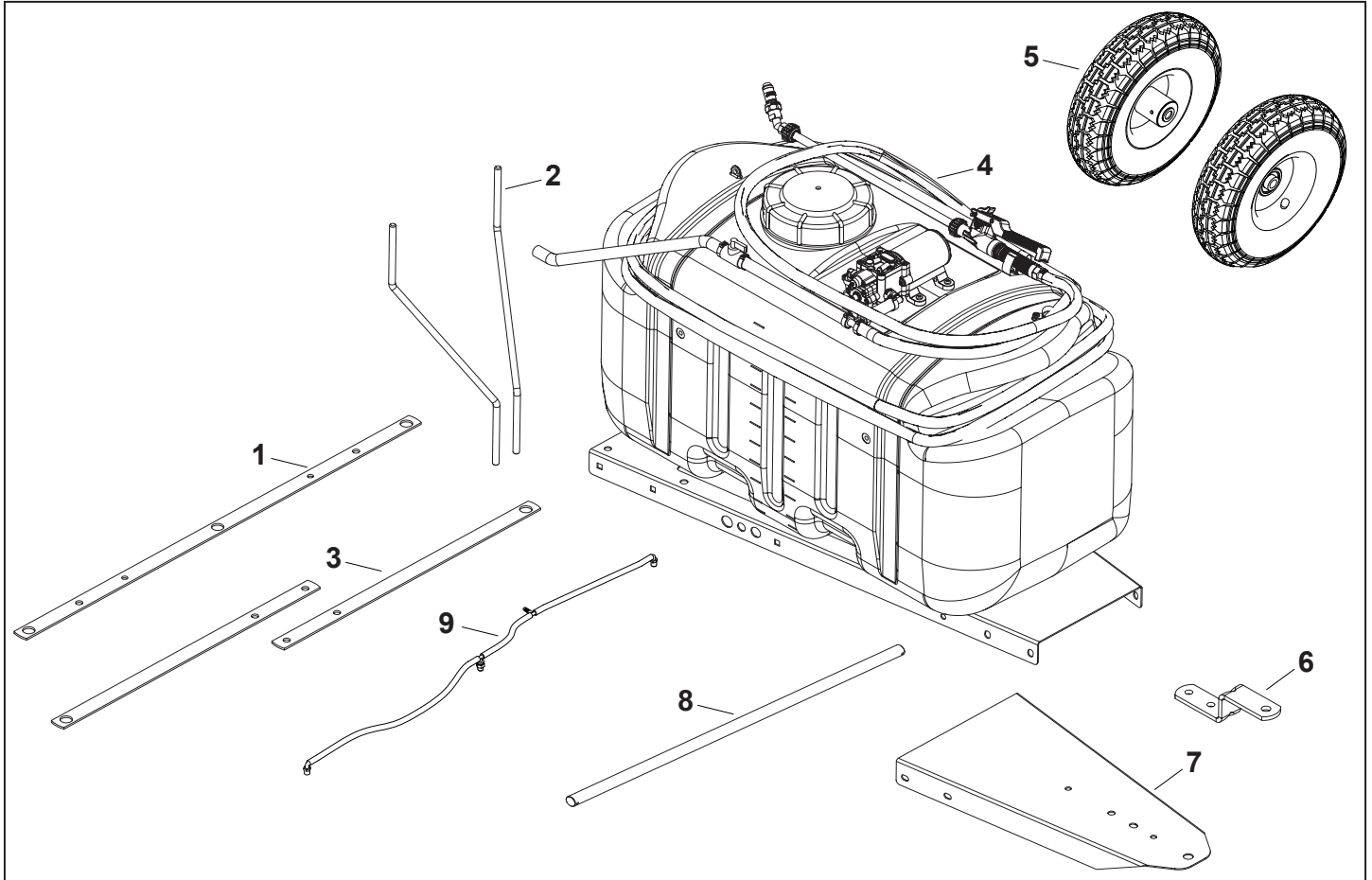

REF.	QTY.	PART NO.	DESCRIPTION
1	1	ST43169BL3	CENTER BOOM
2	2	ST43532	BOOM SUPPORT ROD
3	2	ST43170BL3	BOOM EXTENSION
4	1	-	SPRAYER ASSEMBLY
5	2	45702Y	WHEEL & TIRE ASSY. 4.10/3.5-4
6	1	23014BL1	HITCH BRACKET
7	1	2-896BL3	HITCH TRIANGLE
8	1	2-746	1/2" AXLE
9	1	-	BOOM HOSE ASSEMBLY

Assembly

Hardware Bag

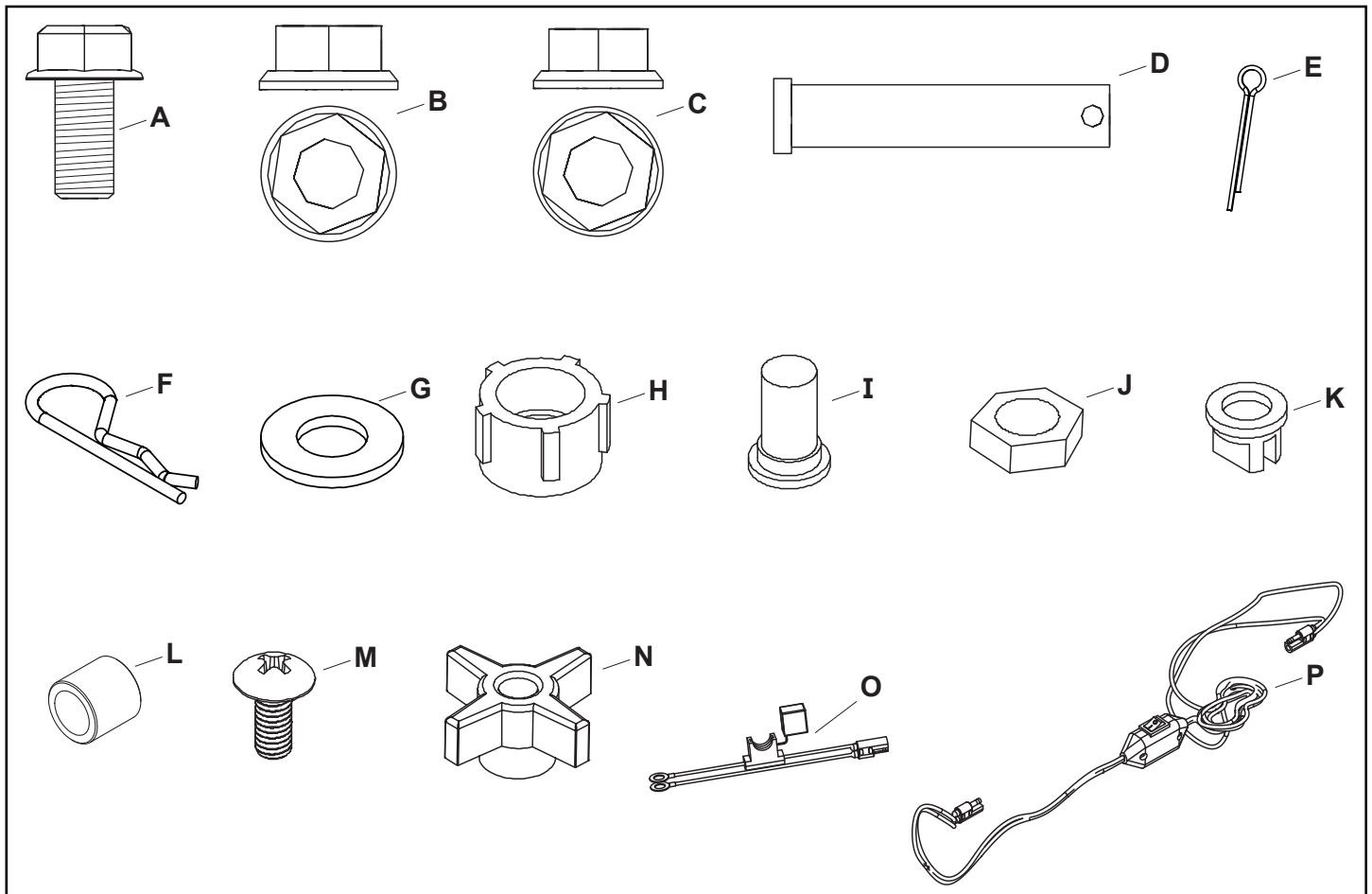

REF.	QTY.	PART NO.	DESCRIPTION	REF.	QTY.	PART NO.	DESCRIPTION
A	6	ST65007	5/16" X 3/4" HEX FLANGE BOLT	J	3	2-866	11/16" NOZZLE RETAINING NUT
B	8	44072	3/8" HEX WHIZLOCK NUT	K	3	2-882	110° FLAT FAN .4 SPRAY TIP
C	6	46584	5/16" HEX WHIZLOCK NUT	L	2	28324	.510ID X .750OD X .70 SPACER
D	1	ST43468	1/2" X 2-1/4" CLEVIS PIN	M	2	43814	5/16" X 3/4" TH PHILLIPS SCREW
E	2	43010	1/8" X 1-1/4" COTTER PIN	N	2	ST43289	3/8" LOCKING KNOB
F	1	714-0117	5/32" X 3" HAIR COTTER PIN	O	1	ST43483	BATTERY WIRE HARNESS
G	4	1540-59	.52 X 1.062 X .09 WASHER	P	1	ST43472	SWITCH WIRE HARNESS
H	3	ST43012	TIP FITTING CAP NUT	-	2	ST43314	PLASTIC WIRE HARNESS CLIP
I	3	ST43016	SPRAY TIP SCREEN W/ CHECK				

Assembly

Attach Hitch Frame

1. Remove hardware bags and wiring harness from inside tank.

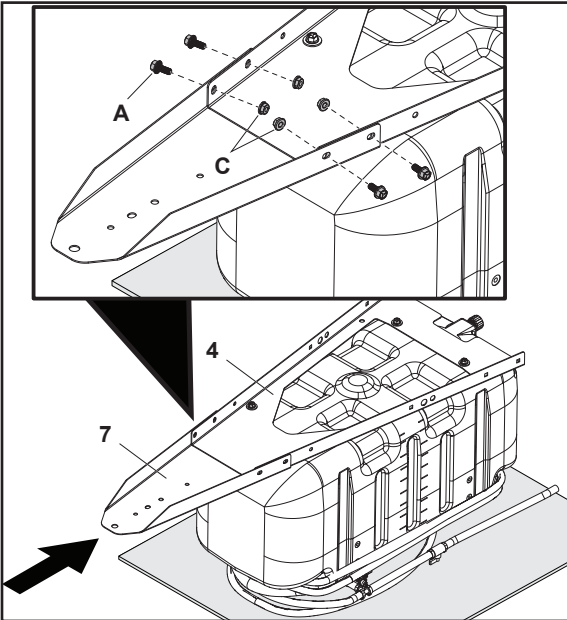

2. Place sprayer assembly, with tank frame on top, onto top of shipping box for installing hitch frame.

NOTE: When installing hardware, always install with nuts to the inside.

3. With tank frame (4) mounted to the inside of the hitch frame (7), align mounting holes on tank frame to mounting holes in hitch frame.
4. Install and tighten hardware:
 - (4) 5/16 in. x 5/8 in. Hex Flange Bolts (A)
 - (4) 5/16 in. Hex Whizlock Nuts (C)

Install Wheels

NOTE: Install wheels so tire valve stems face to the outside of the sprayer frame.

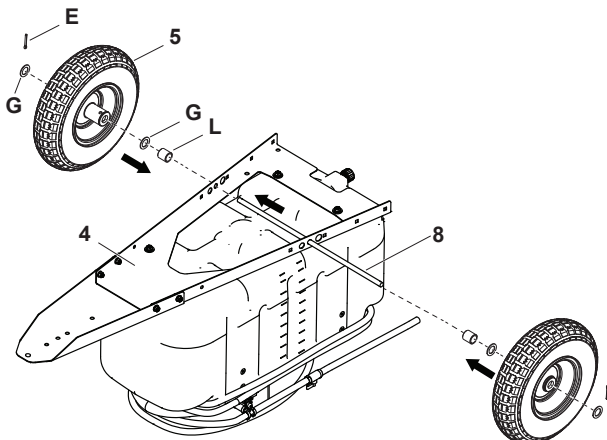

1. Install and center axle (8) into rear smaller holes of tank frame (4).
2. Install axle spacer (L) and flat washer (G).
3. Install wheel (5), and then additional washer (G).
4. Secure with cotter pin (E) by bending the ends.
5. Repeat for opposite wheel.

Wheel hardware:

- (2) Axle Spacers (L)
 - (4) Flat Washers (G)
 - (2) Cotter Pins (E)
6. Lubricate wheel bearing grease fittings with recommended grease.
 7. Set sprayer on wheels.

Install Hitch Assembly

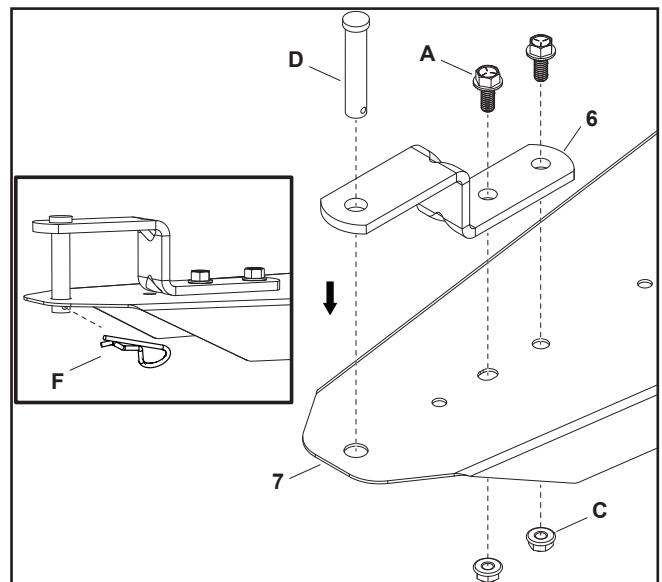

1. Install hitch bracket (6) on top of hitch triangle (7) aligning mounting holes.
2. Install and tighten hardware:
 - (2) 5/16 in. x 3/4 in. Hex Flange Bolts (A)
 - (2) 5/16 in. Hex Whizlock Nuts (C)
3. Install clevis pin (D) through hitch bracket (6) and hitch triangle (7).
4. Secure with hair cotter pin (F)

Assembly

Install Boom Assembly

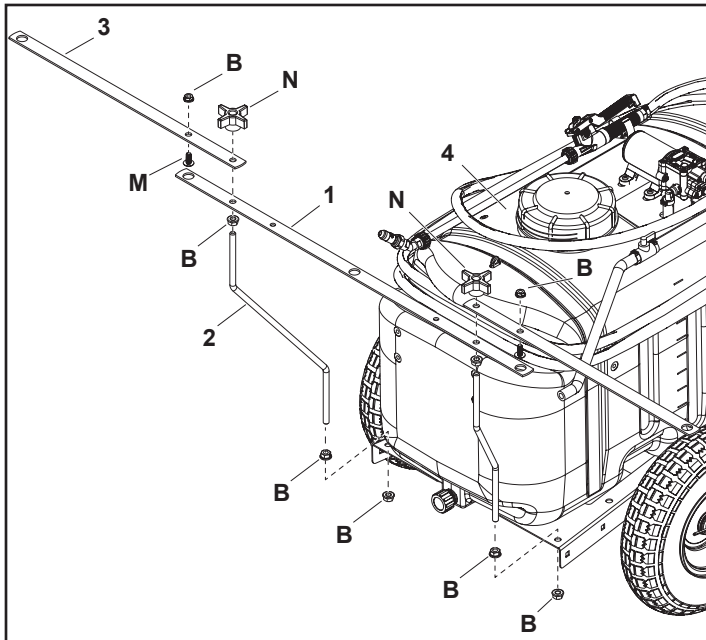

1. Install two hex whizlock nuts (B) on each of the boom support rods (2). (One on each side the the top of the nut facing the support rod.) Thread the nut to the inner end of the threads.
2. Insert the bottom of the boom support rod (2) into the tank frame and then secure with a hex whizlock nut (B). Repeat on other side.
3. Install the center boom (1) onto the boom support rods (2). (Make sure the rods go into the outer most small hole on the center boom.)
4. Tighten hardware from Step 2.
5. Insert phillips screw (M) into inner hole on the boom extension (3) and secure with a hex whizlock nut (B). Tighten hardware. Repeat on other boom extension (3).
6. With the nut facing up on the boom extension (3) insert the outer hole on boom extension onto the boom support rod (2). Tighten with a locking knob (N). Repeat on other side.

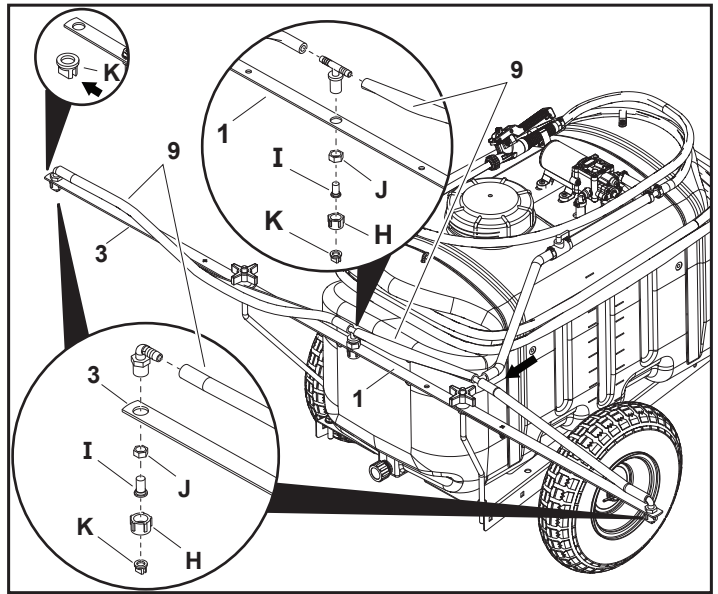

1. Orient the boom hose assembly (9) so the barbed T-fitting is on the right side.
2. Insert the all three nozzle bodies into the holes on flat boom pieces. Route the hose around the knobs (N) like shown in image above.
3. Secure each nozzle body with a nozzle retaining nut (J). Tighten each by hand.
4. Place the spray tip (K) into the tip fitting cap nut. Repeat for the other two spray tips.
5. Install the screen (I) and spray tip/cap nut onto the nozzle body. Tighten by hand. Repeat for other two nozzle bodies.
6. Install the boom hose (coming from sprayer) to the T-fitting on the boom hose assembly (9).

Installation

Install Wiring Harness to Battery

IMPORTANT: Avoid damage! To help prevent electrical spark, install red wire to the positive (+) battery terminal first. Then install black wire to negative (-) battery terminal. To prevent damage to wiring, make sure hood does not close on wires connectors

NOTE: Depending on the location of your battery, a wiring harness-extension may be required. Part numbers are AM105666 (John Deere) or ST43485 -2ft, ST43509-8ft (Agri-Fab). See your John Deere dealer to order parts.

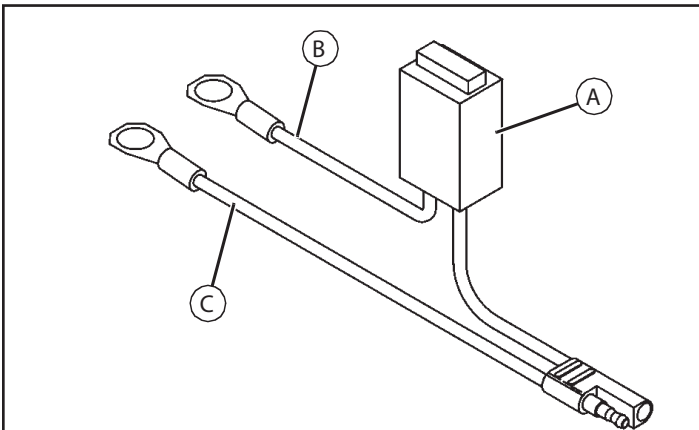

1. Fuse holder (A) should contain a 15 A / 32 V fuse. Make sure fuse filament is not broken.
2. Open hood. If battery is mounted low and behind the grille, carefully unsnap top of grille to provide access to battery terminals.
3. Remove nut from positive (+) battery cable clamp. Install red lead (B) onto clamp bolt. Install and tighten nut completely.
4. Remove nut from negative (-) battery cable clamp. Install black lead (C) onto clamp bolt. Install and tighten nut completely.

Install Wiring Harness (For Machines With Mid-Mounted Battery)

1. Open hood.

NOTE: Switch (A) is not located at center of main wiring harness. The harness plug connector nearest to the switch gets connected to the pump leads.

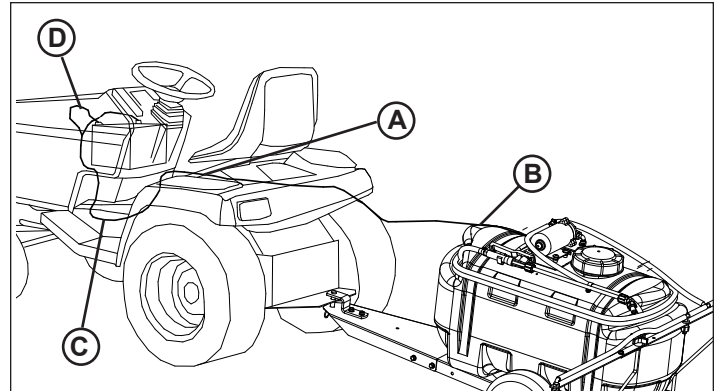

2. Connect main wiring harness to pump leads (B).
3. Route main harness as shown and clip in place at foot rest side panel (C). On some units route harness on right side of fuel tank filler neck.

IMPORTANT: Avoid damage! Avoid damage to wiring. Make sure hood does not close on wiring harnesses. Keep wiring harnesses away from all moving parts and hot surfaces.

4. Connect other end of main harness to fused battery lead (D).
5. Close hood.

Install Wiring Harness Extension (For Machines With Front-Mounted Battery)

1. Connect wiring harness extension (A) to fused harness (B) at battery. Make sure the harness passes between the left side hood rods.

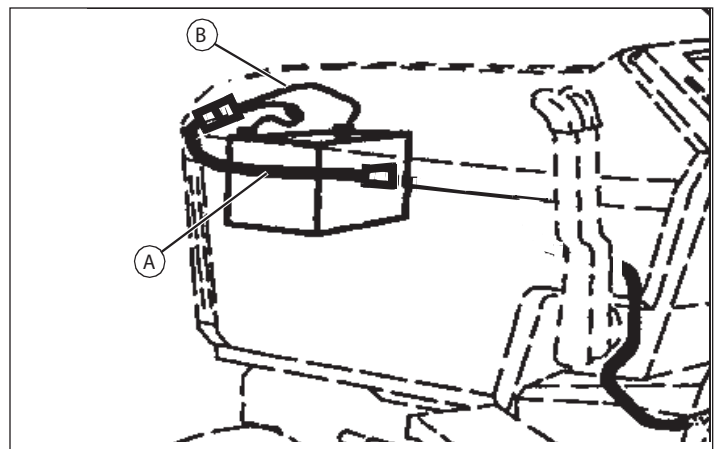

2. Route wiring harness extension through front frame hole.
3. Connect extension to battery lead plug. Then snap front grille in place.

Installation

Install Wire Clips

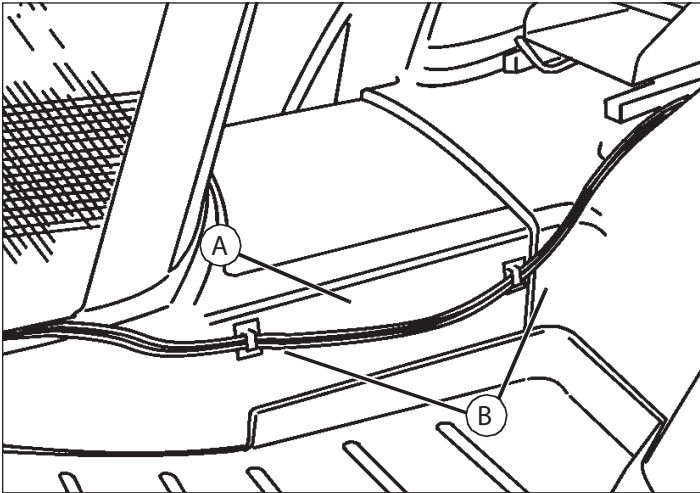

1. Clean foot rest side panel (A) at left side of machine with mild detergent or isopropyl alcohol. Dry thoroughly.
2. Attach wire clips (B) to panel. Position the clips as shown so that sprayer main wiring harness will not interfere with deck height adjustment crank, if equipped.

Preparing Vehicle

Machine Requirements

Sprayer Weight:

- 25 Gallon Sprayer, Filled with liquid is 115 kg (253 lb)

IMPORTANT: Avoid damage! No rear suitcase weights or grass bagging attachments should be installed on machine while using sprayer

Make sure machine tire pressure is correct. (See your machine operator's manual for the correct pressure.)

Machine weights improve stability. Add front weights for better front-end stability and steering. See your John Deere dealer for these weights. Instructions to install will come with the weights.

Your machine requires the following:

- 12-Volt Battery and Alternator
- Wiring Harness Extension: This part is required for all machines with the battery mounted near the front grille. Order this wiring harness from your John Deere dealer. ST43485-24in or ST43509-8ft

Operation

Filling Sprayer Tank

CAUTION: Avoid injury! Chemicals can be dangerous. Avoid injury to operator or bystanders:

- Read chemical container label for mixing and handling instructions. A Material Safety Data Sheet (MSDS) should be supplied by the chemical dealer and provides proper safety information.
- Wear proper clothing and safety equipment while handling or applying spray chemicals.
- Wear a full covering of clothing, protective goggles and rubber gloves.
- Prohibit all smoking, drinking, and eating around chemicals.
- When filling tank, never allow end of water hose to contact chemical mixture.

1. Clean area around tank filler cap to prevent tank contamination.
2. Remove tank filler cap and fill tank.

Transporting Tow Behind Safely

- Push pump switch to off position.

Fold boom extensions in their transport position.

Sprayer weight:

25 Gallon Sprayer - Filled with liquid is 115 kg (253 lb)

Spraying Tips

- Check sprayer tip height. Adjust sprayer tip height, if needed, before operating. 25 Gallon Sprayer, 43 cm (17 in.)
- Do not let sprayer run in one spot.
- Do not over spray when you use weed killers.
- Liquid spray material is recommended. Sprayer does not agitate wettable powders.
- Timely applications of a smaller dosage are better than large applications.
- Turn sprayer off during turns to avoid double spraying.
- Fill sprayer where spills cannot harm grass.
- Follow manufacturer's recommendations for application of specific chemicals.
- Stop sprayer when tank is empty.

Adjusting Tip Height

1. Attach sprayer to machine.
2. Measure from spray tip to ground. Distance to ground should be approximately: 43 cm (17 in.)

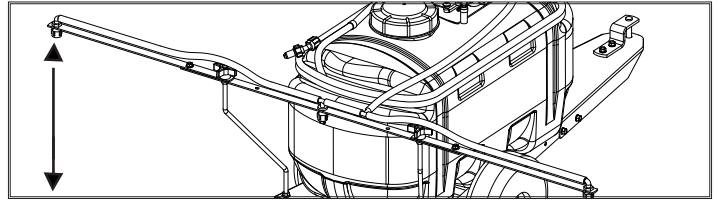

If necessary, adjust boom height by raising or lower the boom on the threaded boom supports (2).

3. Check spray tips (K). Tips should be aligned with boom as shown. If necessary, loosen spray tip cap nut (H). Align spray tip (K) and tighten cap nut.

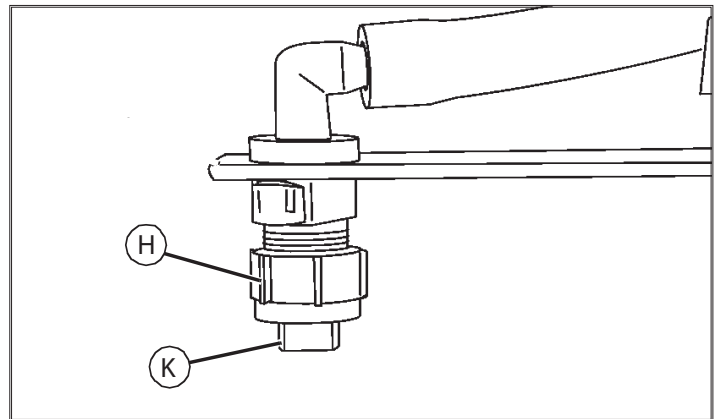

4. Test spray pattern with water on driveway or sidewalk. Each spray tip pattern should spread out to the right and left sides, rather than to the front and back of the boom. There should be some spray overlap between each tip and the spray patterns should be consistent.

Operation

Starting and Stopping Sprayer

IMPORTANT: Avoid damage! Operate sprayer with transport vehicle running to avoid discharging the battery.

NOTE: The sprayer pump to battery hookup is a direct electrical connection. Shutting off the transport vehicle does not prevent operation of the sprayer pump. To avoid accidental spraying, disconnect the pump connection before leaving the sprayer.

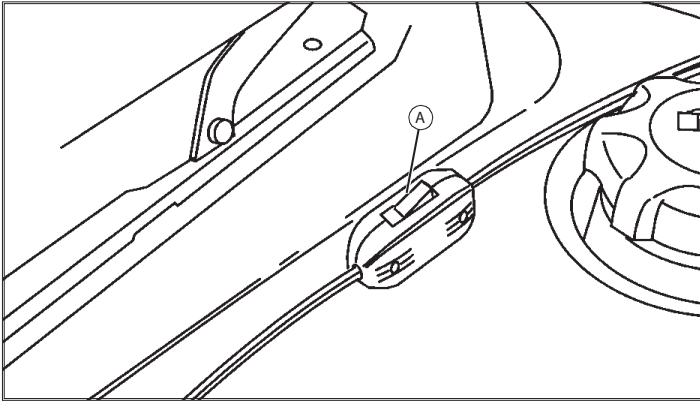

Push switch (A) to on or off position to start or stop sprayer

Boom On/Off

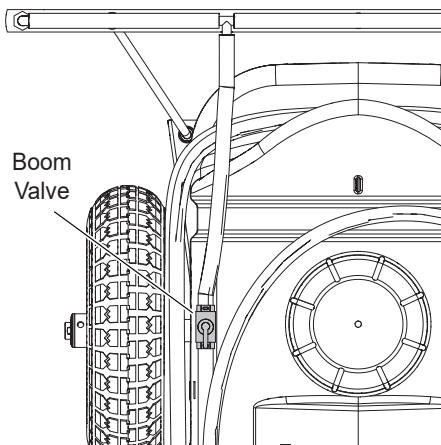

Boom Valve is used to control the boom:

- In the open position (valve in line with hose) fluid will flow to the boom.
- In the closed position (handle perpendicular to hose), fluid will flow to spray wand only.

Pump Pressure Switch

The pump pressure switch turns off the pump when it reaches its maximum pressure setting. Very low flow demand may cause the switch to rapidly cycle the pump on and off. Rapid on and off cycling must be limited to no more than 6 times per minute. Cycling could cause the motor to heat beyond the recommended maximum temperature and reduce the operational life of the pump and pressure switch.

Operating Spray Wand

NOTE: It is not recommended to use wand while operating the machine. Turn machine on for wand use, but do not maneuver machine unless wand and hose are in normal storage position on the tank.

1. Turn shut-off valve lever perpendicular to hose.
2. Squeeze handle (A) to spray.
 - Push lock (B) forward to lock handle into the on position.
3. Adjust nozzle:
 - Nozzle Angle - Loosen locknut (C). Turn nozzle (D) as desired and tighten locknut.
 - Nozzle Spray Pattern - To change spray pattern, tighten or loosen nozzle (D) as desired.

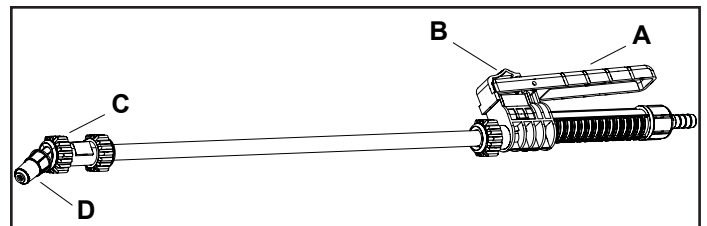

Operation

General Spraying Information

25 Gallon Sprayer Application:

The 25 gallon sprayer operate at a fixed pressure through the boom and spray wand. Although the pressure can be adjusted to the boom by partially opening the boom control valve, it is recommended that the valve is operated in full open position. Use the chart below to select your desired speed and application rate.

Spray Tip Application Chart

GPA & Gal/1000 Sq. Ft.								
Sprayer	Tip Size	PSI	GPM One Nozzle	GPA				
				2 mph	3 mph	4 mph	5 mph	6 mph
25 Gallon	TP11008VP	30	0.69	68.3	45.6	34.2	27.3	22.8

Sprayer	Tip Size	PSI	GPM One Nozzle	Gallons per 1000 Sq. Ft.				
				2 mph	3 mph	4 mph	5 mph	6 mph
25 Gallon	0.4 gpm 110 deg.	30	0.33	.75	.50	.37	.30	.25

NOTICE: Avoid contamination when switching from one chemical to another chemical in the sprayer where contamination must be prevented. Wash with tank cleaner and water throughout the tank, pump, and all hoses. Flush with water two to three times. Herbicides such as 2-4D are hard to remove. Follow instructions on procedures noted on all labels.

Lifting Sprayer Safely

- Use caution when lifting the sprayer to help prevent possible injury.
- Empty tank before attempting to lift.

Transporting Sprayer Safely

- Use caution when transporting the sprayer to help prevent possible injury.
- Push pump switch to OFF position.
- When sprayer is filled with liquid, the extra weight on the back of a machine could change the stability of the machine.

Hand Wand

Pressure	Nozzle	GOM (cone)	GPM (Stream)
60 psi	#18	0.34	1.1
Sprayer Capacity		Approximate Spray Time in Minutes	
25 Gallon		62.5	20

Useful Formulas

GPA = gallons per acre

GPM = gallons per minute

MPH = miles per hour

GAL/1000ft² = gallons per 1000 sq. ft.

W = nozzle spacing in inches

GPM/per nozzle = gpa x mph x w / 5940

GPM/per nozzle = gal/1000ft² x mph x w / 136

GPA = 5940 x gpm (per nozzle) / mph x w

GPA = gallons per 1000 sq. ft. / .023

GAL/1000ft² = 136 x gpm (per nozzle) / mph x w

Removing and Storing

Removing Sprayer

1. Park machine safely. (See Parking Safely in the Safety section.)
2. Empty the sprayer tank.
3. Disconnect the main wiring harness only. Leave all other harnesses installed on machine.
4. Roll up the main harness and store with sprayer.
5. Remove Sprayer:

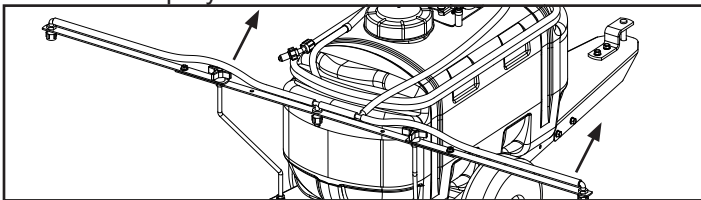

- Loosen locking knob and then fold in boom extensions.

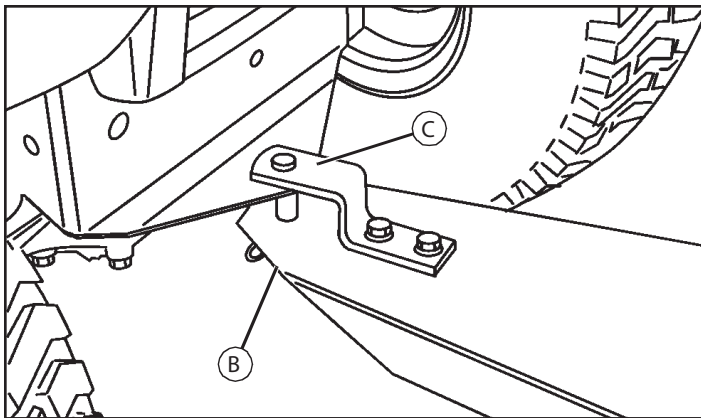

- Pull spring locking pin (B) out of hitch pin (C). Remove hitch pin (C).
- Pull sprayer back from machine.
- Put hitch and spring locking pin in sprayer hitch for storage.

Draining and Cleaning Sprayer Tank

IMPORTANT: Avoid damage!

- **Proper disposal of excess spray is very important. Dilute it with water and apply it to area previously treated.**
- **Never dump excess into a storm drain or near a lake or stream..**

1. Remove tank drain cap, and empty sprayer tank:
 - Empty remaining solution into an appropriated container for proper disposal.
 - Pump 2 gallons of clean water through all wet components.

Note: Fold boom in or use individual containers to catch water from spray tips. Properly dispose of clean out fluid.

2. Spray all inside surfaces of tank with low pressure garden hose to remove any remaining solution. Rinse several times to make sure sprayer tank is clean and free of chemicals.
3. Replace drain cap and run fresh, clean water through pump, sprayer wand and all hoses thoroughly.
4. Once the tank is empty, wipe out inside of sprayer tank with a clean cloth or paper towel.

Store Sprayer Safely

1. Ensure sprayer tank is cleaned and drained.
 - Loosen locking knob and then fold in boom extensions.
2. Remove sprayer from transport vehicle.
3. Check sprayer for worn or damaged parts. Replace parts as needed.
4. Tighten loose hardware.

Service

Checking Tire Pressure

Use tire pressure stamped on side wall of tire.

Tire Size: 4.10 x 3.50 - 4

Clearing Spray Nozzle

CAUTION: Avoid injury! Do not put nozzle tip or other spray parts to your lips to blow out dirt. Use compressed air or clean water.

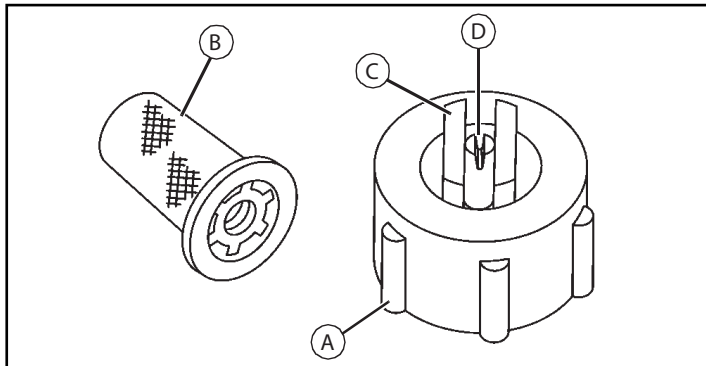

1. Remove spray nozzle (A) from sprayer.
2. Disassemble filter (B) and spray tip (C).

NOTE: Do not use a wire to clean opening (D) in spray tip.

3. Wash filter and spray tip in a non-flammable solvent.
4. Put spray tip in spray nozzle.
5. Put flat side of filter in spray nozzle.
6. Install assembly on sprayer and tighten nozzle.

Cleaning Spray Wand Nozzle

NOTE: There are two different styles of nozzles for your sprayer. See below for explanation of each style.

CAUTION: Avoid injury! Do not put nozzle tip or other spray parts to your lips to blow out dirt. Use compressed air or clean water.

1. Unscrew nozzle (A) from spray tip (B).
2. Loosen nut (C) and remove spray tip (B) from angled fitting on wand.
3. Wash nozzle and spray tip with liquid detergent and warm water.
4. Inspect O-ring (D) and replace as needed.
5. Slide nut over spray tip and install on angled fitting on wand.
6. Install nozzle on spray tip.

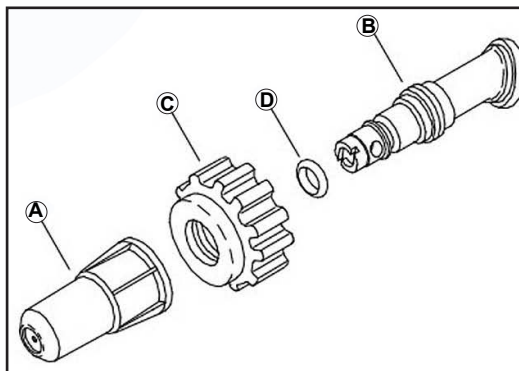

Cleaning Pump Suction Screen

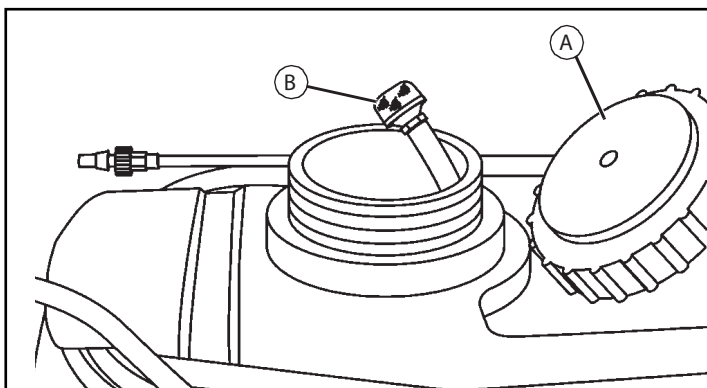

1. Remove tank cover (A).
2. Locate suction screen (B) inside sprayer tank.
3. If necessary, unscrew suction screen and clean with liquid detergent and warm water.
4. If suction screen was removed, install on suction hose and position in lowest depression inside tank.
5. Install and tighten tank cover.

Changing Fuse

IMPORTANT: Avoid damage! The electrical system may be damaged if incorrect replacement fuses are used. Replace the bad fuse with a fuse of the same amp rating.

1. Open hood.
2. Remove fuse from battery harness.
3. Install new 15 amp fuse.
4. Close hood.

Troubleshooting

Using Troubleshooting Chart

If you are experiencing a problem that is not listed in this chart, see your authorized dealer for service.

When you have checked all the possible causes listed and you are still experiencing the problem, see your authorized dealer.

IF	CHECK
Pump Loses Suction	Clean Pump suction screen. Check tank fill level. Fill tank. Clean or replace pump. Check for loose pump fittings.
Pump Capacity Decreased	Clean pump suction screen. Clean spray nozzle(s). Selection lever is not completely turned on, or is in the OFF position.
Poor Spray Pattern	Clean spray nozzles. Adjust nozzle height. Align spray tips with boom.
Pump Does Not Work	Check wiring connections. Check machine battery. Clean debris from pump. Check pump switch. Check pump motor. Check fuse at battery. Adjust pump.

Specifications

Model 25 Gallon Tow Behind Sprayer

Tank95 L (25 gallon)

Pump:

Type Electric Motor and Diaphragm

ManufacturerRemco

Current Draw7 amp

Fuse15 amp

System Pressure 689 kPa (100 psi)

Spray Rate 6 L/min. (1.6 gal./min.)

Suction Hose Strainer. Stainless Steel

Spray Tip Material Plastic

Handgun:

Material. Plastic with Plastic Tip

Adjustment. Fan To Stream

Sprayer:

Nozzle Tip Height 43 cm (17 in.)

Spraying Width 229 cm (90 in.)

Weight:

Empty. 24 kg (53 lb)

Full. 115 kg (253 lb)

Parts Diagram

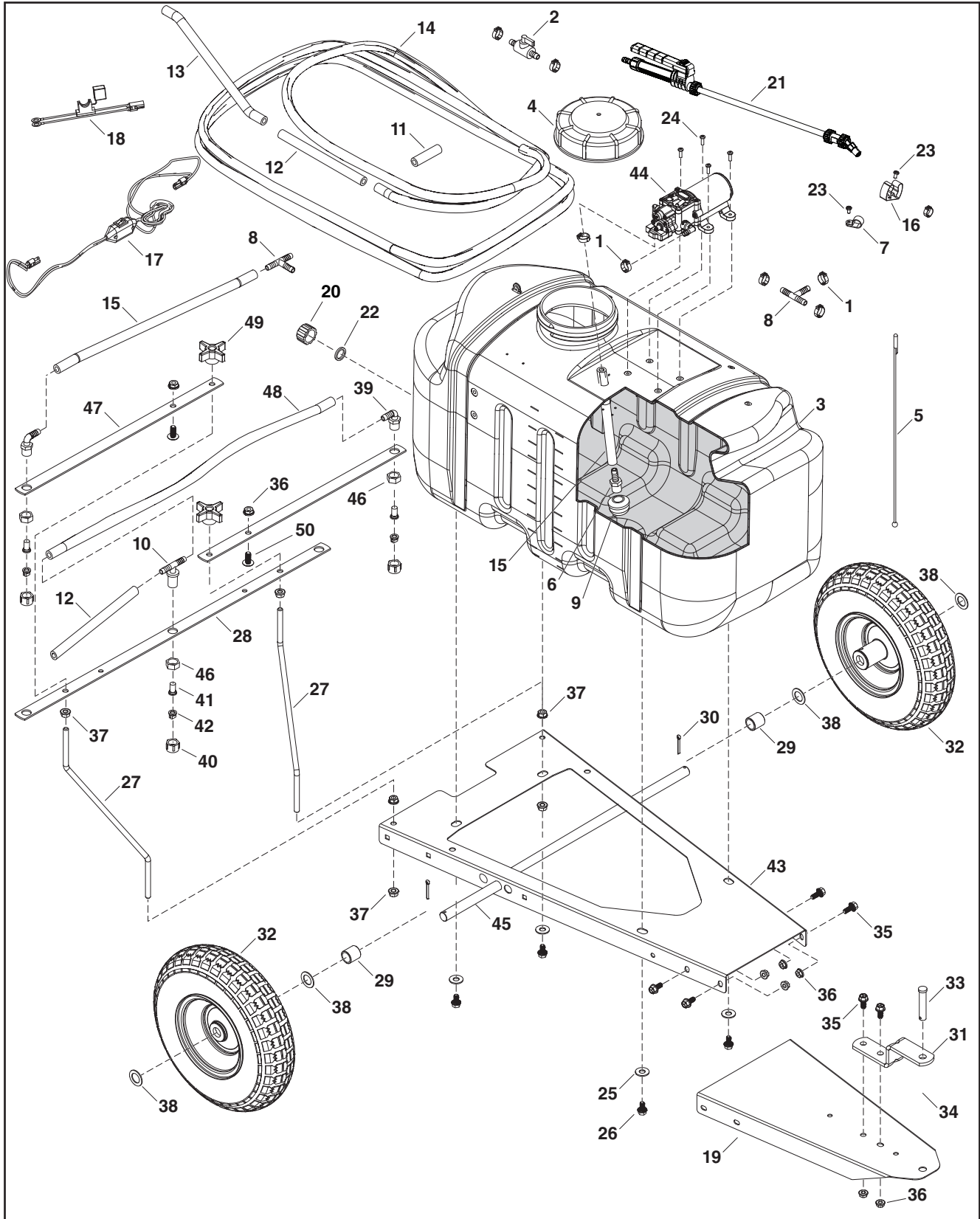

Parts Diagram

REF. NO.	PART NO.	QTY.	DESCRIPTION	REF. NO.	PART NO.	QTY.	DESCRIPTION
1	ST43652	8	HOSE CLAMP, 1/2"	28	ST43169BL3	1	CENTER BOOM
2	ST43014	1	IN LINE VALVE 3/8" BARB	29	28324	2	SPACER, .510ID X .750OD X .70
3	2-1054	1	25 GALLON TANK, DRILLED	30	43010	2	PIN, COTTER 1/8" X 1-1/4"
4	ST43175	1	TANK FILL CAP	31	23014BL1	1	BRACKET, HITCH
5	ST44017	1	LANYARD FOR TANK FILL CAP	32	45702Y	2	WHEEL & TIRE ASS'Y 4.10/3.5-4
6	ST43182	1	SUMP FITTING 3/8" BARB	33	ST43468	1	PIN, CLEVIS 1/2" X 2-1/2"
7	ST43191	1	HOSE HOLDER 3/8"	34	714-0117	1	PIN, 5/32" X 3/4" HAIR COTTER
8	ST43013	2	TEE 3/8" BARBS	35	ST65007	6	BOLT, FLANGE 5/16-18 X 3/4" GR
9	ST43258	1	SUMP STRAINER 3/8"	36	46584	6	NUT, HEX 5/16-18 WHIZ LOC
10	ST43192	1	TEE 3/8" BARBS TIP FITTING	37	44072	8	NUT, HEX 3/8-16 WHIZLOC
11	2-317	1	HOSE, 3/8" X 2.5"	38	1540-31	4	WASHER, .78 X 1.25 X .062
12	2-319	2	HOSE, 3/8" X 8.5"	39	ST43011	2	ELBOW, 3/8" BARB TIP FITTING W
13	2-324	1	HOSE, 3/8" X 15.5"	40	ST43012	3	TIP FITTING CAP NUT
14	2-1049	1	HOSE, 3/8" X 180"	41	ST43016	3	SPRAY TIP SCREEN W/CHECK
15	2-314	2	HOSE, 3/8" X 22"	42	2-882	3	SPRAY TIP, 110 FLAT FAN, 0.4
16	ST43287	1	SPRAY WAND HOLDER, LARGE	43	2-805BL3	1	MAIN FRAME
17	ST43472	1	WIRE HARNESS, SWITCH	44	ST43790	1	PUMP, REMCO 1.6 GPM 100 PSI
18	ST43483	1	WIRE HARNESS, BATTERY	45	2-746	1	AXLE, 1/2" DIA.
19	2-896BL3	1	HITCH TRIANGLE	46	2-866	3	NUT, 11/16" NOZZLE RETAINING
20	48719	1	CAP, 3/4" GHT DRAIN	47	ST43170BL3	2	BOOM EXTENSION
21	2-1050	1	SPRAY WAND, PLASTIC TIP X 18	48	2-325	1	HOSE, 3/8" X 31"
22	ST43684	1	WASHER FOR DRAIN CAP	49	ST43289	2	KNOB, 3/8" LOCKING
23	46677	2	SCREW, 10-24 X 3/8" PL	50	43814	2	SCREW, 5/16-18 X 3/4"
24	ST65258	4	SCREW, PAN #10-24 X 5/8" PHIL.	-	ST43314	2	CLIP, PLASTIC WIRE HARNESS*
25	43070	4	WASHER, .438 X 1 X .083	-	MT3980	1	LABEL, WARNING - CHEMICAL HAZARD*
26	ST65011	4	BOLT, FLANGE 5/16-18 X 5/8" GR	-	3-455	1	OWNERS MANUAL*
27	ST43532	2	BOOM SUPPORT ROD	-	ST50749	1	FUSE 32V 15A ATO/ATC (SERVICE PART)*

* Not Shown

Warranty

Limited Warranty for New John Deere Licensed Products

Agri-Fab's sprayers are guaranteed to be free from defects in material and workmanship from the date of purchase for 2 years residential use, 6 months commercial use, provided that the purchaser properly assembles, installs, uses and maintains the products in accordance with this manual. Purchaser's failure to adhere to such requirements will void the warranty. To the extent permitted by applicable law, all other warranties, representations, obligations and conditions, expressed or implied, including but not limited to implied warranties of merchantability, fitness for any particular purpose and non-infringement, are hereby disclaimed and excluded. Any product which does not meet warranty shall, as purchaser's sole and exclusive remedy, be repaired or replaced by Agri-Fab. This warranty is non transferrable.

In addition, our warranty does not cover:

- Breakage of parts resulting from failure to follow the proper storage procedure, including temporary or seasonal, according to the owner's manual such as draining liquid.
- Loss or consequential, incidental or special damages of any kind

Getting Quality Service

John Deere Quality Continues with Quality Service

John Deere provides a process to handle your questions or problems, should they arise, to ensure that product quality continues with quality parts and service support.

Follow the steps below to get answers to any questions you may have about your product.

1. Refer to your attachment and machine operator manuals.
2. In North America or Canada, call Agri-Fab at 800-448-9282 and provide product serial number (if available) and model number.

This product was manufactured by Agri-Fab, Inc, a John Deere Licensee, located at 809 S Hamilton Street Sullivan, IL 61951. If you have any questions or concerns with the assembly, installation, or operation of this attachment, see your local John Deere dealer or call Agri-Fab at 800-448-9282 for assistance.

