

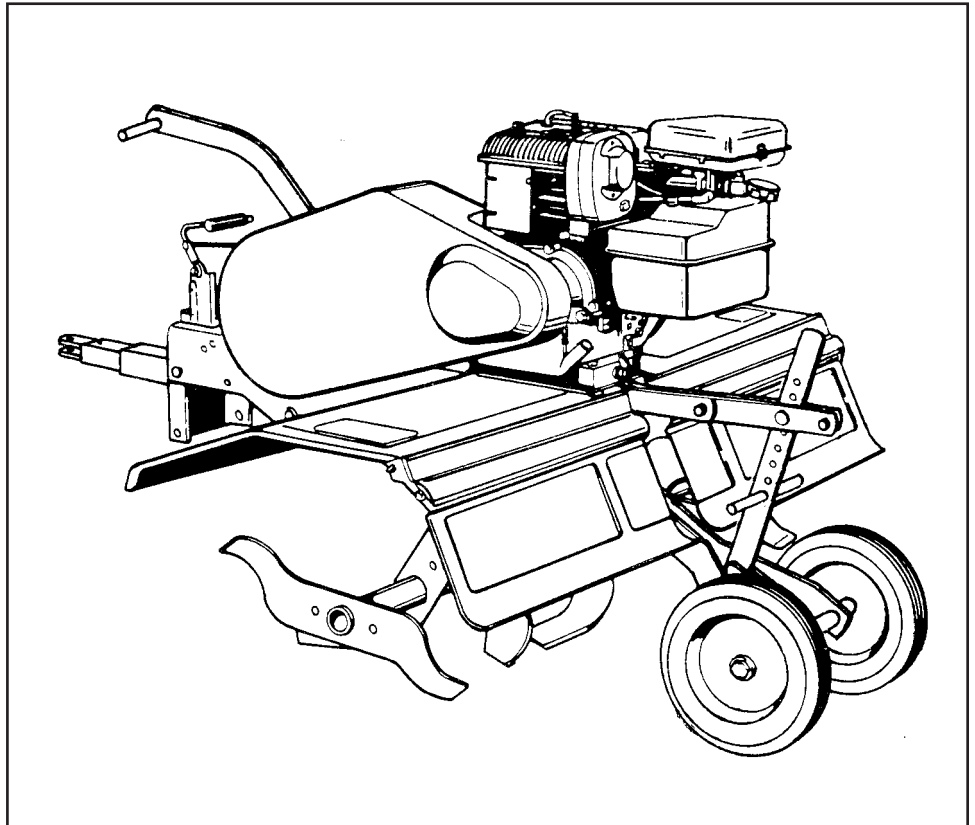

## OWNER'S MANUAL

**MODEL NO.  
45-03085  
45-03086**



## UNIVERSAL TOW BEHIND TILLER

**IMPORTANT!** The engine is shipped without oil. Oil must be added before starting the engine. See Engine Maintenance on page 9 of this manual for instructions.

**CAUTION:**  
Read Rules for  
Safe Operation  
and Instructions  
Carefully

- **Assembly**
- **Operation**
- **Customer Responsibilities**
- **Service and Adjustment**
- **Repair Parts**

**SpeedPart** *the fastest way to purchase parts* [www.speedepart.com](http://www.speedepart.com)

# TABLE OF CONTENTS

**SAFETY RULES** ..... 3  
**ASSEMBLY** ..... 4  
**OPERATION** ..... 5-7  
**MAINTENANCE** ..... 8-9  
**SERVICE AND ADJUSTMENT** ..... 10-11

**STORAGE** ..... 11  
**TROUBLESHOOTING** ..... 12  
**REPAIR PARTS** ..... 13-15  
**PARTS ORDERING/SERVICE** ..... Rear Cover

Congratulations on your purchase of a tow behind tiller. It has been designed, engineered and manufactured to give you the best possible dependability and performance.

Please read and retain this manual. The instructions will enable you to assemble and maintain your tiller properly. Always observe the **SAFETY RULES**.

## CUSTOMER RESPONSIBILITIES

- Read and observe the safety rules.
- Follow a regular schedule in maintaining, caring for and using your tiller.
- Follow the instructions under **MAINTENANCE** and **STORAGE** sections of this Owners Manual.

**MODEL NUMBER:** 45-03085, 45-03086

**SERIAL NUMBER:** \_\_\_\_\_

**DATE OF PURCHASE:** \_\_\_\_\_

THE MODEL AND SERIAL NUMBER WILL BE FOUND ON THE MODEL PLATE ATTACHED TO THE RIGHT HAND CHASSIS.

YOU SHOULD RECORD BOTH SERIAL NUMBER AND DATE OF PURCHASE AND KEEP IN A SAFE PLACE FOR FUTURE REFERENCE.

## PRODUCT SPECIFICATIONS

<b>OIL (20 oz. Capacity):</b>	Above 32 F: SAE 20 Below 32 F: SAE 5W30
<b>TILLING GROUND SPEED:</b>	Approx. 2 MPH
<b>TILLING WIDTH:</b>	36 in.
<b>TILLING TINE SPEED:</b>	230 RPM

This unit is equipped with an internal combustion engine and should not be used on or near any unimproved forest covered, brush covered, or grass covered land unless the engine's exhaust system is equipped with a spark arrester meeting applicable local or state laws (if any). If a spark arrester is used, it should be maintained in effective working order by the operator.

In the state of California the above is required by law (Section 4442 of the California Public Resources Code). Other states may have similar laws. Federal laws apply on federal lands. A spark arrester muffler is available at your nearest authorized engine service center.



# SAFETY RULES



## IMPORTANT

Warnings, Cautions and Notes are a means of attracting attention to important or critical information in this manual.



**LOOK FOR THIS SYMBOL TO POINT OUT IMPORTANT SAFETY PRECAUTIONS. IT MEANS — ATTENTION! BECOME ALERT! YOUR SAFETY IS INVOLVED**

## TRAINING

- Read Assembly and Service instructions carefully. Be thoroughly familiar with the controls and the proper use of the equipment.
- Never allow children to operate the machine. Do not allow adults to operate the machine without proper instruction.
- Keep the area of operation clear of all persons, particularly small children and pets.

## PREPARATION

- Check the fuel and lubrication before starting the engine. Do not fill the gasoline tank indoors when the engine is running or while the engine is still hot. Wipe off any spilled gasoline before starting the engine.
- Inspect the area to be tilled. Remove glass, wire, metal objects, large sticks and stones. Avoid underground pipes and wiring.
- Have a complete working knowledge of your tractor and know how to handle your tractor with a tiller or other attachment attached.

## OPERATION

- Give complete and undivided attention to the job at hand. Operate the tiller in daylight or good artificial light.
- Personal injury may result from contact with the tines or debris thrown by this machine. Therefore, always stay a safe distance away from tines.
- Stop the tiller engine when leaving your tiller unattended.
- Check before each use for loose fasteners or parts.
- Always stop engine and disconnect spark plug lead wire before cleaning tines, removing obstacles or making adjustments unless specifically told by the instructions to leave the engine running.

- Never place hands or feet under or into rotating parts or concealed areas. Keep hands and feet clearly away from tine elements, belts, pulleys, etc., while engine is running.
- Wear substantial shoes and eye protection while using tiller.
- Never attempt to make a maintenance adjustment except on the carburetor while engine is running.
- Do not run the engine indoors; carbon monoxide fumes are dangerous to inhale.
- Never operate machine without proper guards, plates or other safety protective devices in place.
- Disengage the Tine Drive Clutch, stop tiller and tractor engines before getting off the tractor.
- Disengage the Tine Drive Clutch and stop the tiller engine during transportation to and from the work area.

## MAINTENANCE AND STORAGE

- Never store the equipment with gasoline in the tank inside of a building where fumes may reach an open flame or spark. Allow the engine to cool before storing in an enclosure.
- Follow maintenance instructions as outlined in this manual and your Engine Owners Manual supplied with the unit.
- Disconnect spark plug wire before making any maintenance adjustment or repair.
- Store gasoline in an approved metal container in a cool, dry place.
- Keep all nuts, bolts and screws tight. Keep machine in good operating condition and keep safety devices in place.
- Safety and performance levels can be assured only by the use of specified replacement parts.

# ASSEMBLY

## TO REMOVE UNIT FROM CARTON

- Cut from top to bottom all four corners of the carton and lay panels flat. See figure 1.
- Remove the lag screw that holds the floating hitch to the packing skid.
- Disassemble and discard carton's wood top and side supports.
- Remove four hex bolt, hex nuts and flat washer from the hold down brackets at the rear of the carton.
- Remove and save the two Flat Washers and Cotter Pins from rear axle. Reuse when attaching gauge wheels.
- Discard all other packing hardware and hold down brackets.

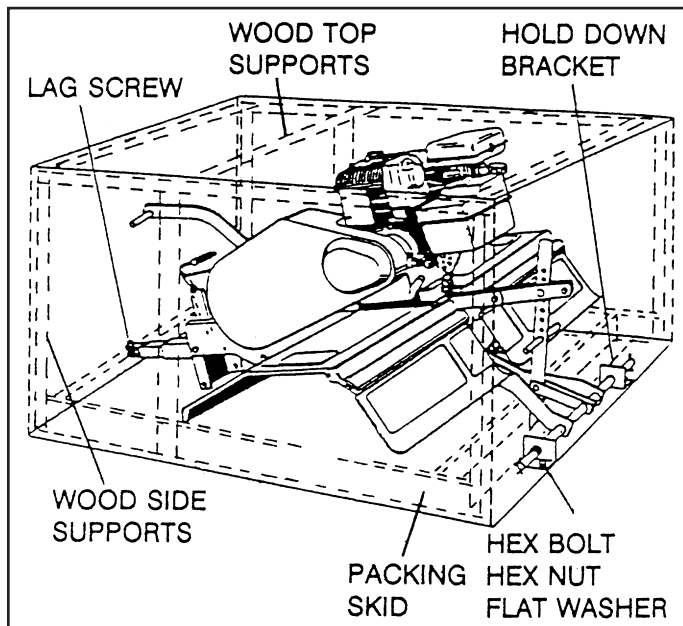

FIGURE 1

## TO INSTALL THE TILLER GAUGE WHEELS

- Assemble Gauge Wheels onto the Rear Axle with the extended end of Hub facing inward. Secure with the Flat Washers and Cotter Pins which you removed from the axle during unpacking. See figure 2.

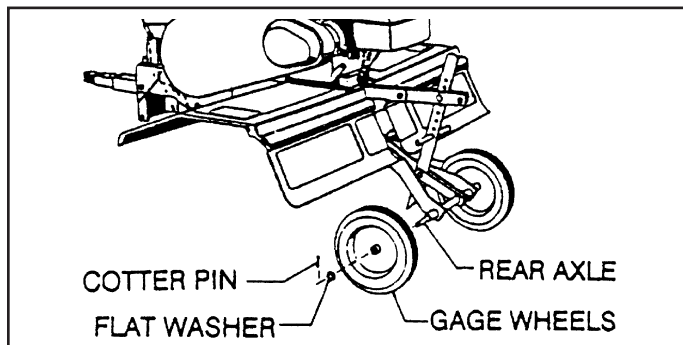

FIGURE 2

## TO INSTALL THE TILLER TINE ASSEMBLIES

- Attach the floating hitch to the tractor's draw bar. Refer to **OPERATING INSTRUCTIONS** on page 6.
- Remove the preassembled 3/8" x 2" hex bolt and 3/8" nylock nut from the L.H. Tine Assembly. Slide the tine assembly onto the Transmission Axle on the left side of the tiller and secure with the hex bolt and nylock nut. See figure 3. Repeat for the R.H. side.

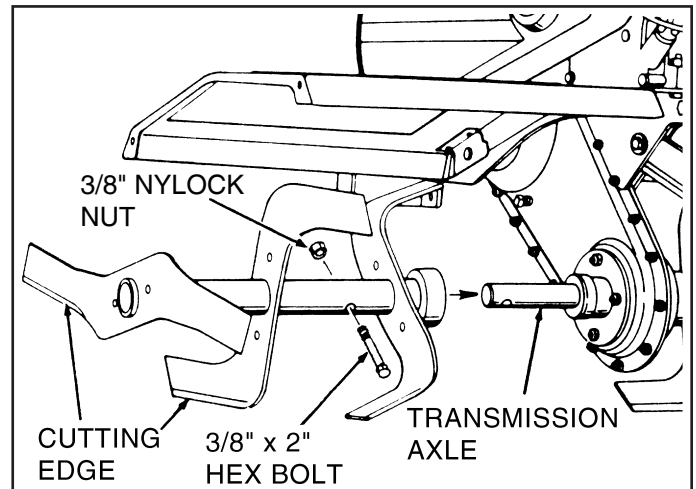

FIGURE 3

## TO INSTALL (WHEEL) WEIGHTS TO TILLER

**NOTE:** Weights are not furnished with Tiller. 30 lb. tractor wheel weights may be purchased to mount to Tiller if extra weight is required. (Refer to **OPERATION** section.)

- Remove two Hex Bolts and Nuts from each Tine Shield, located approximately 3-1/2" from front edge. See figure 4.
- Place (Wheel) Weights on Tine Shield and secure with long Bolts and Nuts furnished with Weights. See figure 4.

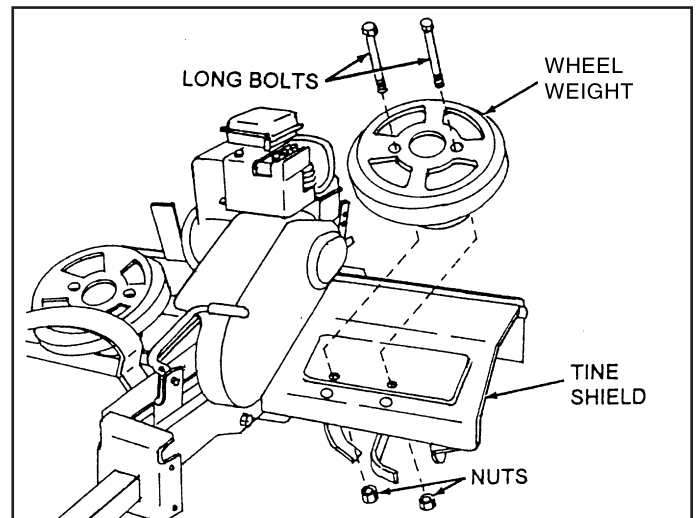

FIGURE 4

# OPERATION

RIGHT HAND (RH) AND LEFT HAND (LH) ARE DETERMINED FROM THE DRIVERS POSITION WHILE SEATED ON THE TRACTOR.

WE RECOMMEND THAT YOU REMOVE THE MOWER DECK BEFORE USING THE TILLER. REFER TO YOUR TRACTOR OWNER'S MANUAL.

## KNOW YOUR TILLER

Compare the illustration below with your tiller to familiarize yourself with the location of various controls and adjustments.

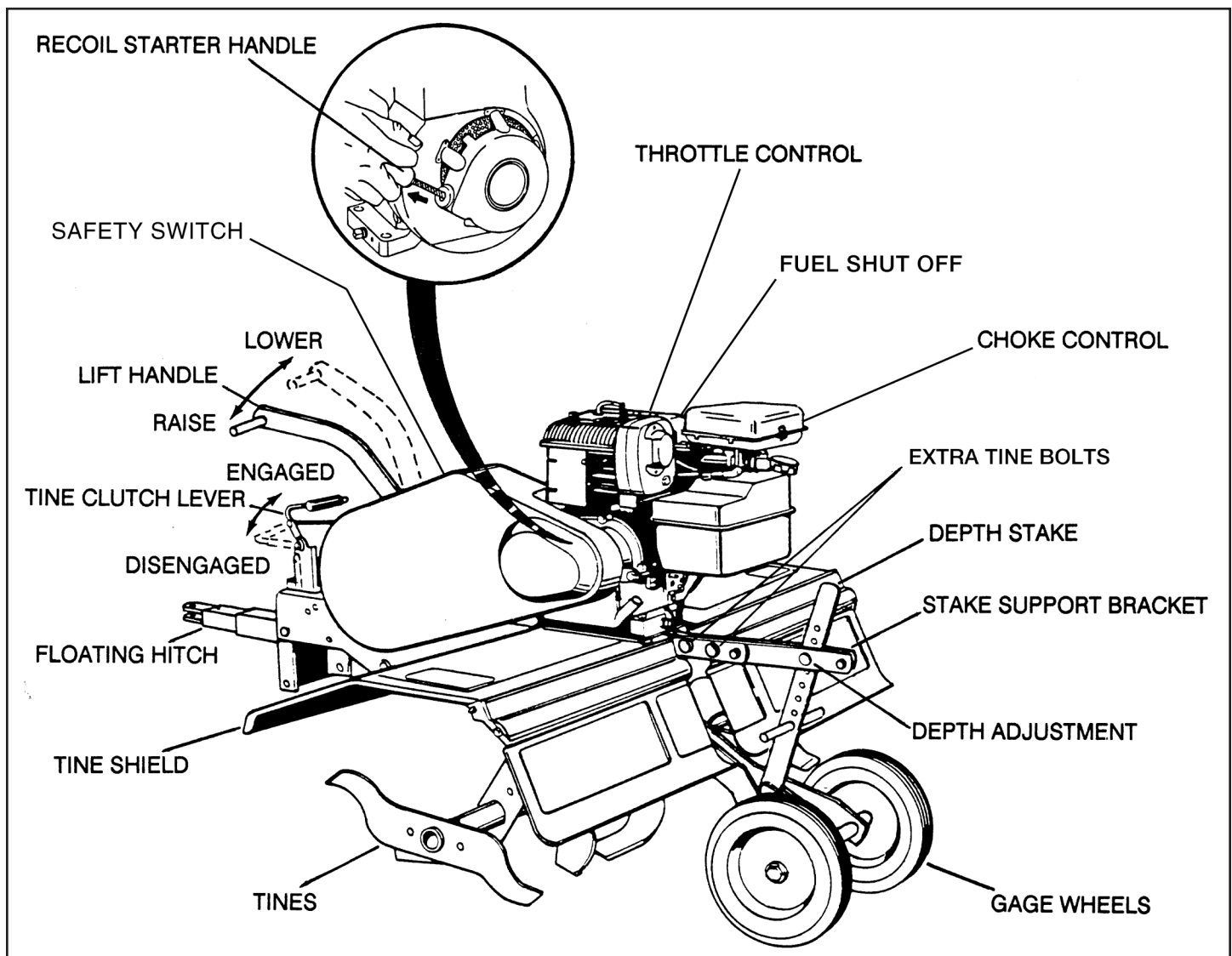

FIGURE 5

**SAFETY SWITCH** - prevents engine from starting while tine clutch lever is engaged

**LIFT HANDLE** - selects tilling or transport position by moving gage wheels

**TINE CLUTCH LEVER** - starts and stops tine rotation

**FLOATING HITCH** - telescoping hitch limits shock loads to tractor

**RECOIL START HANDLE** - used to start the engine

**THROTTLE CONTROL** - controls engine speed

**FUEL SHUT OFF** - shuts off fuel to engine

**CHOKE CONTROL** - used when starting a cold engine

**DEPTH STAKE** - controls tilling/cultivating depth

# OPERATION



The operation of any tiller can result in foreign objects thrown into the eyes, which can result in severe eye damage. Always wear safety glasses or eye shields before starting your tiller and while tilling. We recommend a wide vision safety mask for over the spectacles or standard safety glasses.

## HOW TO USE YOUR TILLER

### BEFORE STARTING YOUR TILLER

**FILL THE ENGINE WITH OIL!** Your tiller engine is shipped without oil or gasoline. Add oil as instructed in Engine Maintenance on page 9 of this manual. Add gas as instructed in the separate engine manual.



**WARNING:** Never fill fuel tank indoors, or with the engine running, or while the engine is hot. Do not smoke while filling tank.

### STOPPING YOUR TILLER

#### TINES

- Raise tiller to transport position.
- Pull forward on tine clutch lever.

ENGINE (Refer to separate engine manual.)

- Move throttle control to "STOP" position.
- Turn shut off to "OFF" position.
- Never use choke to stop engine.

### STARTING YOUR TILLER

(Refer to separate engine manual.)



**CAUTION:** The muffler and adjacent areas are hot!

- Check oil and gas in Tiller engine.
- Attach spark plug wire to spark plug.
- Pull forward on tine clutch lever to disengage tines. A safety switch prevents engine from starting while tines are engaged.
- Turn shut off to "ON" position.
- Move choke lever on engine to CHOKE position. (A warm engine may not require choking.)
- Move throttle control lever on engine to FAST position.
- Grasp starter handle and pull rope out slowly until engine reaches start of compression cycle (rope will pull slightly harder at this point). Let the rope rewind slowly.
- Pull rope with a rapid, continuous, full arm stroke. Keep a firm grip on starter handle. Let rope rewind slowly. Do not let starter handle snap back against starter.

- Repeat instructions in two preceding paragraphs until engine fires. When engine starts, move choke control gradually to RUN position.
- Allow engine to warm up for a few minutes before engaging tines.

### ATTACHING TILLER TO TRACTOR

(See Figure 6)

- Rear wheel weights and tire chains can be used on tractor if additional traction is required for tilling.
- Place Tiller on ground level and back up tractor to it.
- Attach Hitch Bracket Extension to Floating Hitch of tiller with a Hitch Pin and Hair Cotter Pin
- Fasten Hitch Bracket Extension to Tractor Drawbar with a 1/2-13 x 1-1/4" Hex Bolt and 1/2" Nylock Nut.

**HITCH BRACKET EXTENSION CAN BE ATTACHED AS SHOWN IN FIGURE 6 OR TURNED UPSIDE DOWN FOR TRACTORS WITH SHORTER DRAWBARS.**

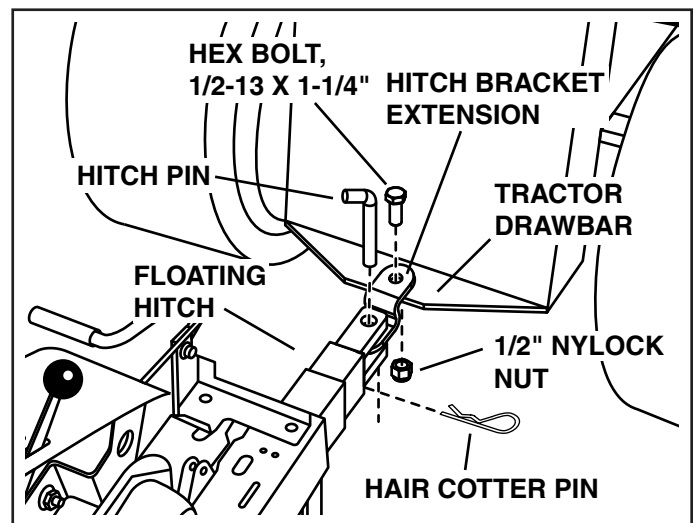

FIGURE 6

### BREAKING IN YOUR TILLER

Break-in your belts, pulleys and the control before you actually begin tilling.

- Start engine with tiller attached to tractor in transport position. Engage Tine Clutch Lever to start tine rotation. Allow tines to rotate for five minutes.
- Check tine operation and adjust if necessary. See tine section in the **SERVICE AND ADJUSTMENTS** section of this manual.



---

# OPERATION

---

## TRANSPORTING YOUR TILLER AROUND THE YARD

- Pull forward on lift handle until it locks in the up, transport position.

## AROUND TOWN

- Disconnect spark plug wire.
- Drain fuel tank.
- Transport in upright position to prevent oil leakage.

## TO ADJUST DEPTH STAKE

- Depth stake has five position holes to select tilling depth from 1 to 5 inches.
- The top stake hole selects the shallowest tilling depth and the bottom stake hole selects the deepest position.
- To change depth remove the hair cotter pin from the clevis pin which is connecting the depth stake to the stake support bracket.
- Grasp the top of the depth stake, remove the clevis pin and reposition the depth stake. Insert clevis pin and hair cotter pin.

**IMPORTANT:** The depth stake should never be removed from the tiller. It is designed to protect the tractor transaxle from thrusting action of the tiller.

## TILLING

- The most efficient tillage is obtained when tiller engine is operated at full throttle. The sound of the tiller engine will tell you. When tiller engine is lightly loaded, raise gauge wheels to increase tilling depth. If engine seems to be overloaded or stalls out, lower gauge wheels for shallower tilling.
- Operate tiller engine at full throttle and operate tractor in slowest forward speed, with tractor engine at idle speed or just above idle. You will soon learn the proper combination of tilling depth and speed for good tillage.
- Soil conditions will determine how deep tiller can penetrate on the first pass. In extremely hard ground, several passes may be necessary to till to a depth of 6 inches. While in soft ground, tiller may penetrate to a depth of 6 inches in the first pass.

## TILLING HINTS

Important operating hints

**NOTE:** The following is a general guideline of tilling, but may vary depending upon soil conditions.

- In virgin soil, the tiller should be started in the shallowest depth position and lowered one position at a time after each pass in each position.

- If the soil is extremely hard and dry, it may be desirable to cross till an area at shallow depth first, then till in the direction of planting rows on the second pass at the final depth.
- Where possible, we recommend tilling in a pattern similar to that shown in Figure 7. Make the first pass, then skip a space equal to the width of the tiller, and make the return pass. Then till the skipped area. Tilling in this pattern will enable you to maintain better control. If the passes were made side-by-side, the tractor and tiller would tend to pull toward the tilled (soft) side.
- Check ground moisture: If you can make a ball in your hand out of the ground to be tilled, do not till soil as it is too wet. This causes lumps which are difficult to work up.
- When operating for the first time, proceed slowly and carefully until you become familiar with the proper method of operating the tiller.
- In soil that was tilled the year before, select the tilling depth at which the tiller engine runs comfortable and does not stall or pull down. Lower depth for additional passes if greater depth is desired.
- Whenever working multiple passes, go perpendicular to the previous tilling direction.
- In cases where the soil is too hard to get proper penetration or if the tilling action causes tiller to hop or bounce, it will be necessary to purchase a set of tiller (wheel) weights.

## CULTIVATING

- Your tiller may be used for cultivating which requires a minimum of two (2) inches of soil penetration.
- Set depth stake so the tiller will penetrate soil to a depth of 2 to 3 inches. The tiller engine should be run at full throttle except when cultivating small plants. A slower engine is necessary to prevent burying the plants. See Figure 8.

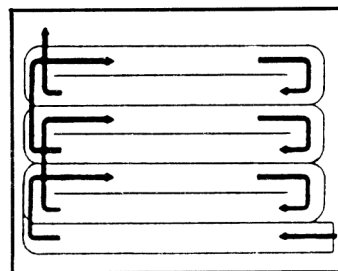

FIGURE 7

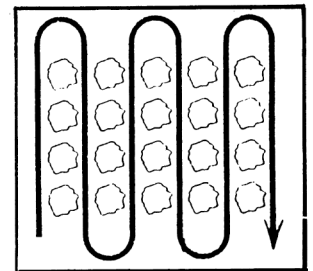

FIGURE 8

# MAINTENANCE

## GENERAL RECOMMENDATIONS

The warranty on this tiller does not cover items that have been subjected to operator abuse or negligence. To receive full value from the warranty, operator must maintain unit as instructed in this manual.

Some adjustments will need to be made periodically to properly maintain your unit. All adjustments in the **SERVICE AND ADJUSTMENTS** section of this manual should be checked at least once each season.

- Once a year you should replace the spark plug, clean or replace air filter and check tines and belts for wear. A new spark plug and clean air filter assure proper air-fuel mixture and help your engine run better and last longer.

## BEFORE EACH USE

- Check engine oil level.
- Check tine operation.
- Check for loose fasteners.

## LUBRICATION

Keep unit well lubricated (See **LUBRICATION CHART**.)

Refer to the engine manual for instructions on engine maintenance.

MAINTENANCE SCHEDULE Fill in dates as you complete regular service.	Before each use	First 5 to 8 hrs.	25 hrs. or every season	50 hrs. or every season	100 hrs or every season	Yearly	Service Dates											
Check Engine Oil Level	X																	
Change Engine Oil		X		X*														
Service air cleaner precleaner			X**															
Service air cleaner cartridge					X**													
Replace spark plug					X													
Clean cooling system					X**													
Check valve clearance						X												
Check for loose fasteners	X																	
Lubricate Tiller			X															

\*Change oil every 25 hours when operating the engine under heavy load or in high temperatures.

\*\*Clean more often under dusty conditions or when airborne debris is present. Replace air cleaner parts, if very dirty.

- REFER TO SEPARATE ENGINE OPERATING & MAINTENANCE INSTRUCTIONS
- REFER TO **MAINTENANCE, TILLER LUBRICATION** SECTION.
- GENERAL PURPOSE GREASE

**IMPORTANT:** DO NOT OIL OR GREASE PIVOT POINTS. VISCOUS LUBRICANTS WILL ATTRACT DUST AND DIRT THAT CAN CAUSE WEAR ON PIVOT POINTS. IF YOU FEEL THEY MUST BE LUBRICATED, USE ONLY A DRY POWDERED GRAPHITE TYPE LUBRICANTS.

## LUBRICATION CHART

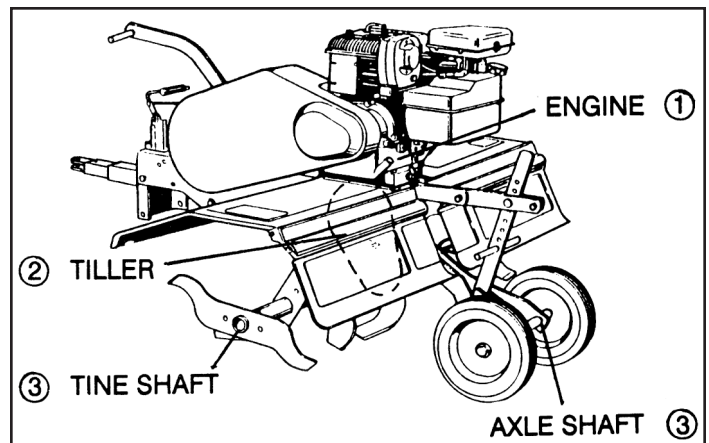

FIGURE 9



# MAINTENANCE

## TRANSMISSION LUBRICATION

Check the transmission oil level after first 5 hours of operation. Remove oil fill plug (figure 10). Oil level must be even with the plug hole (with tiller level). If necessary, add oil. Use SAE 30 non-detergent motor oil. Replace oil fill plug.

Check the transmission oil level after each 10 hours of operation.

**NOTE:** It is not necessary to change the oil in this tiller transmission. If for any reason it must be changed, oil capacity is 22 oz.

## BEARING LUBRICATION

Grease the tine shaft bearings every 8-10 hours. Use a grease gun to apply about 10 pumps of General Purpose grease in the grease fittings. Wipe off excess grease that is forced out of the bearings. For dry and dusty environments, perform this lubricating procedure more often.

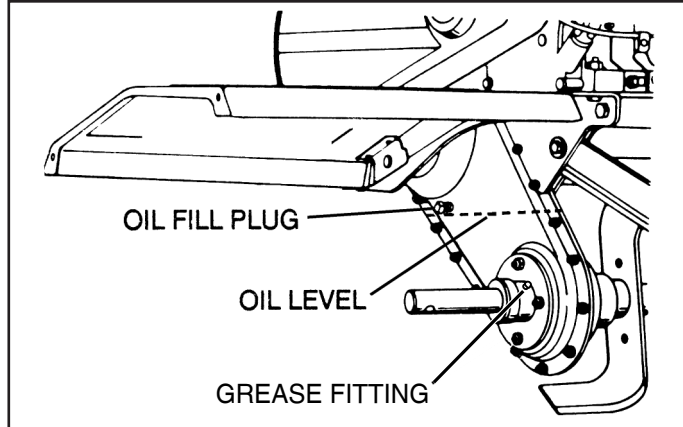

FIGURE 10

## CLEANING

- Clean engine as instructed in the engine manual.
- Clean wheels, finish, etc. Of all foreign matter.
- Keep finished surfaces and wheels free of all gasoline, oil, etc.
- Protect painted surfaces with automotive type wax.

We do not recommend using a garden hose to clean your unit unless the muffler, air filter and carburetor are covered to keep water out. Water in engine can result in shortened engine life.

## MUFFLER

Do not operate tiller without muffler. Do not tamper with exhaust system. Damaged mufflers or spark arresters could create a fire hazard. Inspect periodically and replace if necessary. If your engine is equipped with a spark arrester screen assembly, remove every 50 hours for cleaning and inspection. Replace if damaged.

## ENGINE MAINTENANCE



**WARNING:** Always stop engine and disconnect spark plug wire before cleaning, lubricating or before performing any repairs or maintenance.

- Check **oil level** before each use and every 8 hours.
- Maintain engine oil as instructed in figure 11 below.
- Service **air cleaner** every 25 hours under normal conditions. Clean every few hours under extremely dusty conditions. Poor engine performance and flooding usually indicates that the air cleaner should be serviced. To service the air cleaner, refer to the separate engine manual.
- **Spark plug** replacement is recommended every 100 hours or yearly. Check the engine manual for correct plug type and gap specifications.

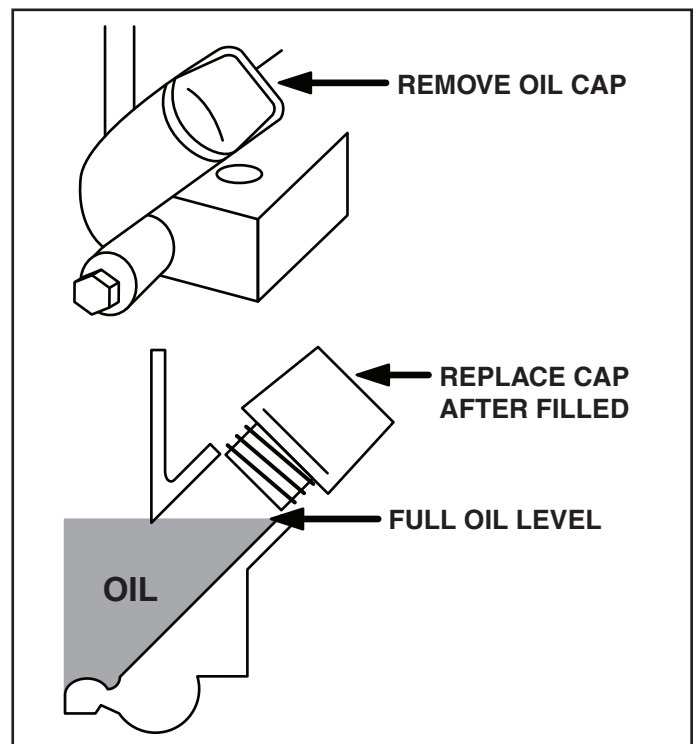

FIGURE 11

# SERVICE AND ADJUSTMENTS



**WARNING:** Shut off (disengage) the Tine Clutch Lever, the Tiller Engine and the Tractor Engine before making any repairs.

## TO REPLACE V-BELT

Replace V-belt if it has been damaged considerably from slipping under heavy loads or if it show cracks or frayed edges. Refer to figures 12 and 13.

**IMPORTANT:** Do not move or remove the belt guide. If the position of the belt guide is accidentally altered, return it to the correct setting (6-1/2" above the tine shield support plate).

- Remove the screw from the top of the belt guard.
- Remove the hex nut from the rear of the guard.
- Remove the belt guard to allow access to drive belt.
- Disengage tine clutch lever and remove belt.
- Reverse above procedures for installation of new belt.

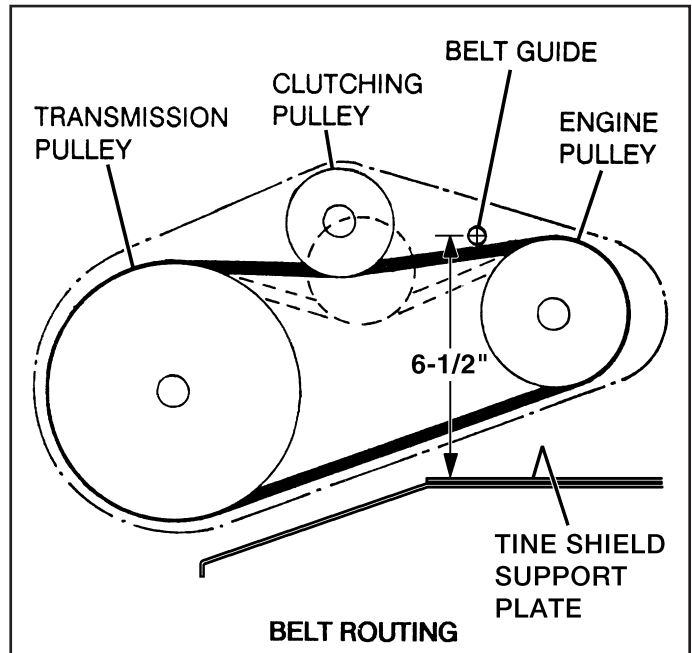

FIGURE 13

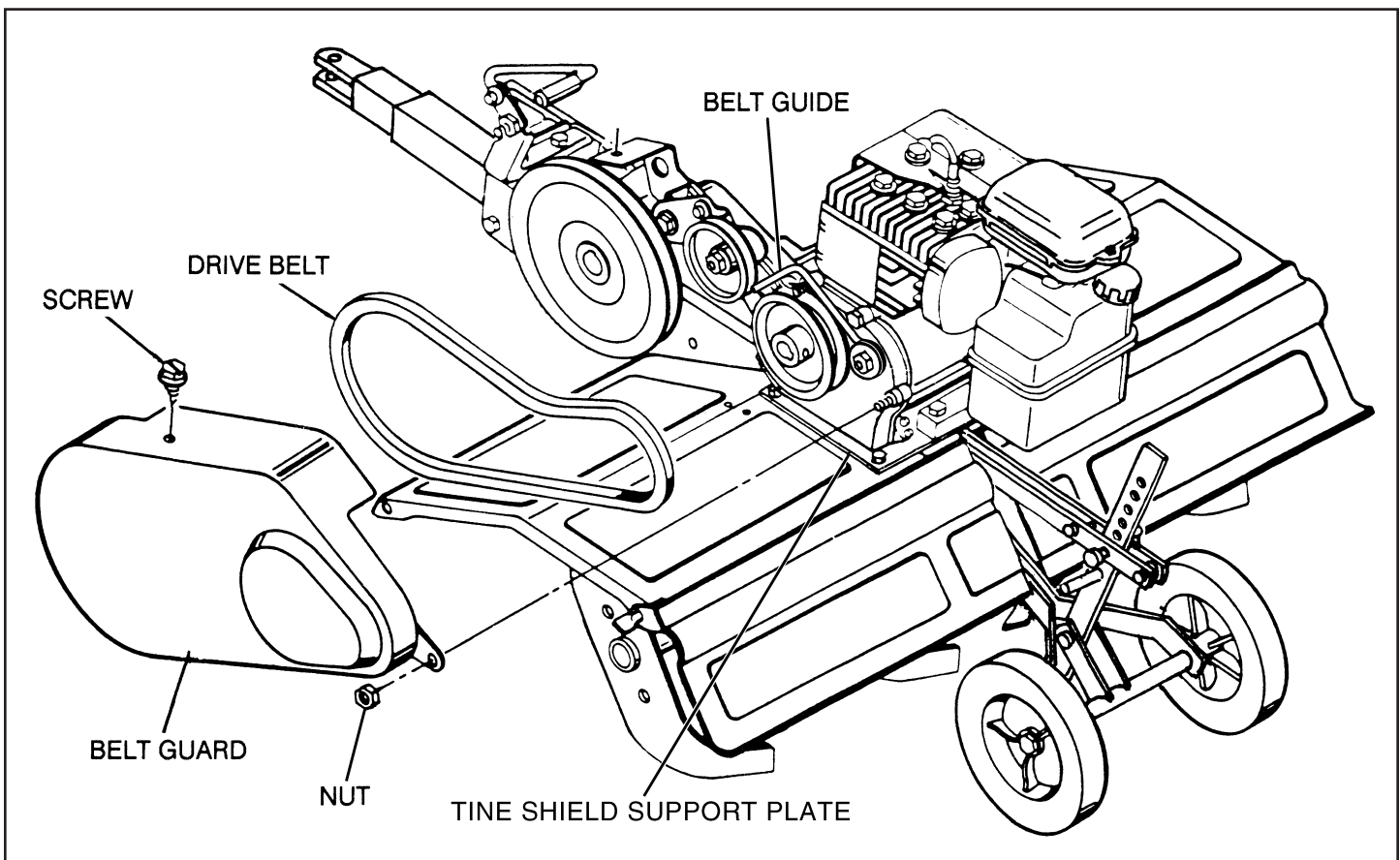

FIGURE 12

---

# SERVICE AND ADJUSTMENTS

---



**WARNING:** Shut off (disengage) the Tine Clutch Lever, the Tiller Engine and the Tractor Engine before making any repairs.

## TINE CARE

- For best results — Tine Blades should be kept reasonably sharp. The Tine Blade can be sharpened on a grinding wheel. Do not attempt to sharpen Tines while they are mounted to Tiller.

## SPARE TINE DRIVE BOLTS

- The Tiller drive components are protected from damage by (shearable) Grade 5 hex bolts in the Tine Assemblies. The hex bolts drive the tines and hold them in the proper location. Should the Tine Assemblies strike or pick up a large hidden object or become jammed, the hex bolts will break and the drive components will not be damaged.
- Two extra tine hex bolts and nuts are included with the tiller. They are located in the Tiller Stake Support Bracket on the rear of the Tiller.
- The tine hex bolts are designed to be loose fit. Do not attempt to use a bolt or pin that is larger or harder than the original Grade 5 hex bolts.

---

## STORAGE

---

Immediately prepare your tiller for storage at the end of the season or if the unit will not be used for 30 days or more.



**CAUTION:** Never store the tiller with gasoline in the tank inside a building, where fumes may reach an open flame or spark. Allow the engine to cool before storing in any enclosure.

## ENGINE

- Follow the instructions in the **SERVICE & STORAGE** section of the Engine Manual.

- Be sure that all nuts, bolts and screws are securely fastened. Inspect moving parts for damage, breakage and wear. Replace if necessary.
- Touch up all rusted or chipped paint surfaces; sand lightly before painting.
- If possible, store tiller indoors and cover it to protect from dust and dirt.
- Cover tiller with a suitable protective cover that does not retain moisture. Do not use plastic. Plastic cannot breathe, which allows condensation to form and will cause your unit to rust.



**WARNING:** Never cover Tiller while engine and exhaust areas are still warm.

## TILLER

- Clean entire tiller (See **CLEANING** in the **MAINTENANCE** section of the manual).
- Inspect and replace belts, if necessary (See belt replacement instructions in the Service and Adjustments section of this manual).
- Lubricate as instructed in the **MAINTENANCE** section of this manual.

# TROUBLESHOOTING

Follow the instructions in the "Service & Storage" section of the Engine Manual when performing any work on the Engine.

<b>PROBLEM</b>	
Probable Cause	Possible Remedy
<b>WILL NOT START OR HARD TO START</b>	
No gasoline in fuel tank	Fill tank with gasoline
Choke not set properly	Place choke control in choke position
Throttle control not set properly	Place throttle control in fast position
Choked improperly, flooded engine	Move choke control to run position, place throttle control in fast position and pull starter several times to clear out gas
Dirty air cleaner	Remove to inspect, replace if dirty
Loose spark plug wire	Make sure spark plug wire is seated properly on spark plug
Spark plug dirty or improper gap	Replace spark plug and adjust gap
Water in gasoline or old fuel	Drain fuel tank and carburetor, use fresh fuel and replace spark plug
Clogged fuel tank	Remove and clean
<b>ENGINE MISSES OR LACKS POWER</b>	
Engine overloaded	Set depth stake and wheels for shallower tilling
Partially plugged air cleaner	Remove and clean or replace
Dirty air screen	Clean air screen
Spark plug dirty, improper gap or wrong type	Replace spark plug and adjust gap
Oil in gasoline	Drain and refill tank and carburetor
Clogged fuel tank	Remove and clean
Poor compression	Major engine overhaul
<b>ENGINE OVERHEATS</b>	
Low oil level or dirty oil	Add or change oil
Dirty air screen	Clean air screen
Dirty engine	Clean cylinder fins air screen and muffler area
Partially plugged muffler	Remove and clean muffler
<b>EXCESSIVE BOUNCE AND DIFFICULT HANDLING</b>	
Wheels and depth stake incorrectly adjusted	Adjust wheels and depth stake
Ground too dry and hard	Moisten ground or wait for more favorable soil conditions
<b>SOIL BALLS UP OR CLUMPS</b>	
Ground too wet	Wait for more favorable soil conditions
<b>ENGINE RUNS WELL BUT TILLER WON'T MOVE</b>	
Tine control not engaged	Engage tine control
V-belt off of pulleys	Check v-belt
<b>ENGINE RUNS WELL BUT LABORS WHEN TILLING</b>	
Tilling too deep	Adjust depth stake
Throttle control not properly adjusted	Check throttle control setting

# REPAIR PARTS FOR MODEL 45-03085, 45-03086 UNIVERSAL TOW BEHIND TILLER

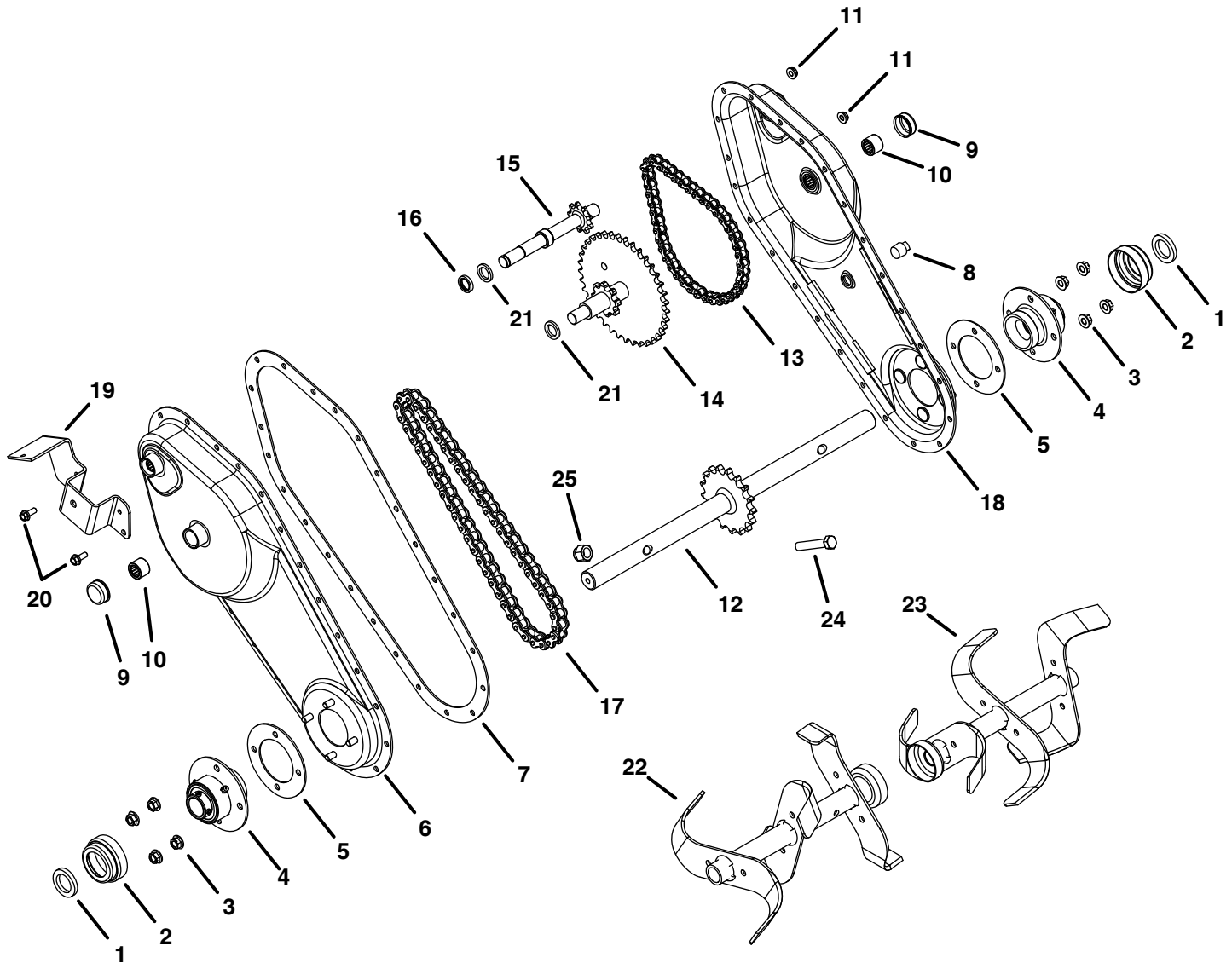

REF.	PART NO.	QTY.	DESCRIPTION	REF.	PART NO.	QTY.	DESCRIPTION
1	HA20125	2	Felt Washer	14	66270	1	Idler Shaft Assembly
2	26707	2	Cap	15	66271	1	Input Shaft Assembly
3	49983	8	Flanged Lock Nut, 5/16-18	16	HA20145	1	Seal
4	66641	2	Flange and Bearing Assembly	17	42087	1	Roller Chain (Long)
5	HA20122	2	Flange Gasket	18	66720	1	Drive Housing (RH) (includes items 9 & 10)
6	66721	1	Drive Housing (LH) (includes items 9 & 10)	19	HA20134	1	Belt Guard and Idler Bracket
7	HA20136	1	Drive Gasket	20	40560	19	Washer Head Bolt, 1/4-20 x 5/8"
8	HA20130	1	Oil Plug	21	HA20129	4	Thrust Washer
9	HA20138	3	Bearing Cap	22	66225	1	Tine Assembly (LH)
10	HA20137	4	Roller Bearing	23	66224	1	Tine Assembly (RH)
11	47598	19	Washer Faced Lock Nut, 1/4-20	24	43054	4	Bolt, 3/8-16 x 2" (2 spare)
12	66269	1	Tine Shaft and Sprocket Assembly	25	HA21362	4	Nut, Hex Nylock 3/8-16 (2 spare)
13	42088	1	Roller Chain (Short)				

# REPAIR PARTS FOR MODEL 45-03085, 45-03086 UNIVERSAL TOW BEHIND TILLER

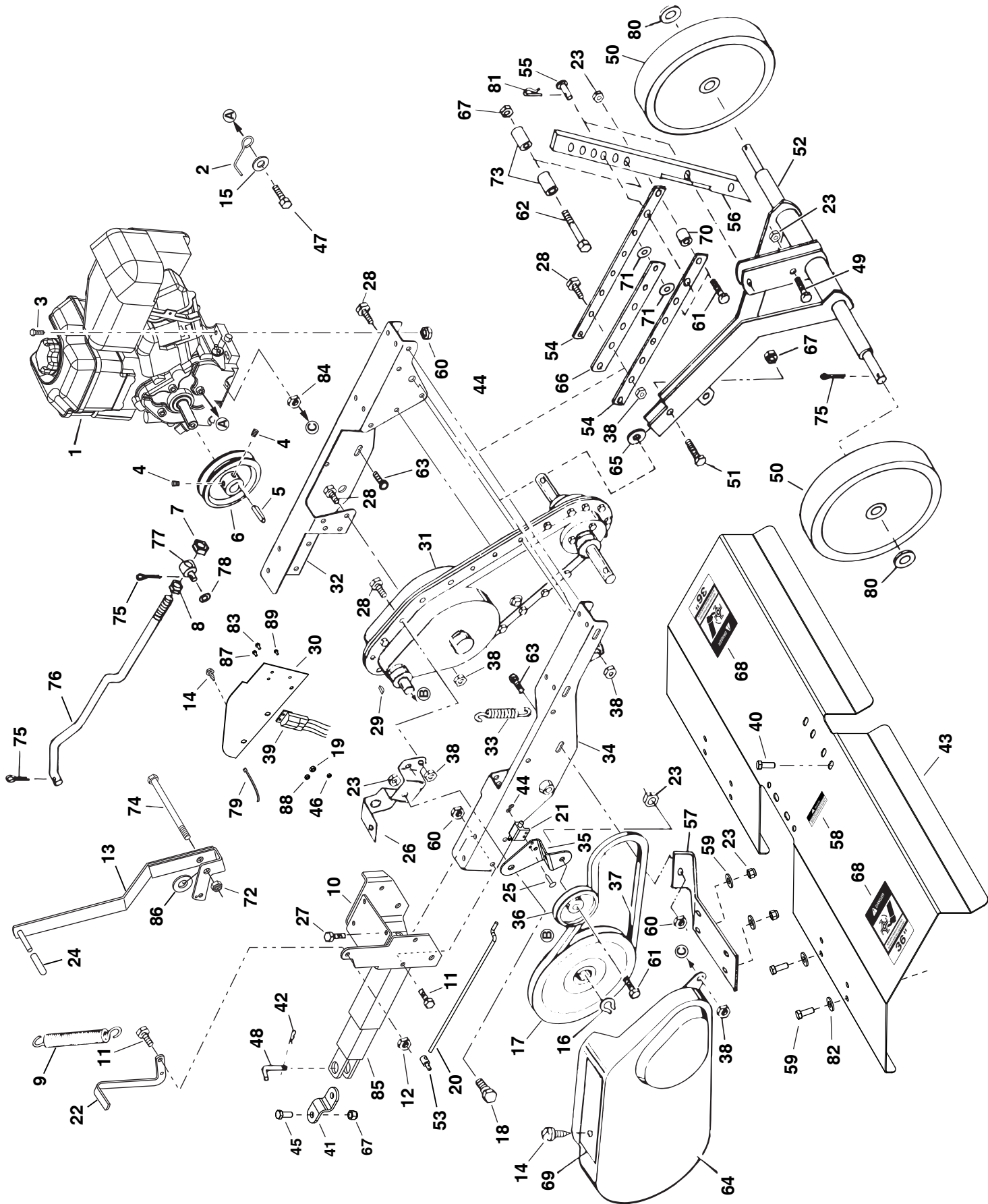



# REPAIR PARTS FOR MODEL 45-03085, 45-03086 UNIVERSAL TOW BEHIND TILLER

REF.	PART NO.	QTY.	DESCRIPTION	REF.	PART NO.	QTY.	DESCRIPTION
1	40993	1	Engine (49 State)	46	40711	1	Nylock Nut, 8-32
	40997	1	Engine (California)	47	47600	1	Bolt, Hex 5/16-24 x 1"
2	48346	1	Guide - Belt	48	HA5236	1	Pin, Hitch
3	43085	4	Bolt, 5/16-18 x 1-1/2" Hex Head	49	43062	1	Bolt, 3/8-16 x 1-1/2" Hex Head
4	HA115321	2	Set Screw, 5/16-18 x 5/16"	50	HA20918	2	Wheel
5	HA11154	1	Key, Square 1/4" x 2"	51	R74780828	1	Bolt, 1/2-13 x 1-3/4" Hex Head
6	40906	1	Pulley	52	HA20670	1	Pivot Axle Assembly
7	48733	1	Nut, 1/2-12 Nylock Jam	53	26568	1	Anchor
8	HA124934	1	Nut, 1/2-12 Hex Jam	54	HA20725	2	Strap Frame Extension
9	HA19860	1	Spring, Depth Extension	55	HA3433	2	Pin, Clevis
10	64282	1	Hitch Bracket Assembly	56	HA20690	1	Stake, Drag
11	43063	5	Bolt, 5/16-18 x 1" Hex Head	57	HA20932	2	Bracket, Wheel Weight Support
12	43064	1	Locknut, 5/16-18 Hex	58	HA20940	1	Decal, Danger
13	64343	1	Lift Handle Assembly	59	43001	8	Hex Bolt, 3/8-16 x 1"
14	48840	3	Screw, Self-Tapping 1/4" x 1/2"	60	47810	11	Nut, Hex 5/16-18 Nylock
15	43081	1	Washer, 5/16" Std. Wrt.	61	41576	5	Bolt - 3/8-16 x 1-3/4" Hex Head
16	HA20135	2	Ring, Retainer	62	R74760884	1	Bolt, 1/2-13 x 5-1/2" Hex Head
17	HA20184	1	Pulley, Input	63	44326	2	Bolt, 5/16-18 x 1" Carriage
18	HA20178	1	Bolt - Shoulder	64	24849	1	Belt Guard (incl. #69)
19	47189	1	Nut, Hex Nylock 1/4-20	65	HA14306	1	Washer
20	40843	1	Clutch Rod	66	HA20691	1	Strap-Frame Extension Brace
21	HA23199	1	Switch, Safety Interlock	67	712-3083	3	Nut, 1/2-13 Nylock
22	24847	1	Lever, Clutch	68	HA20938	2	Decal, Danger
23	HA21362	15	Nut, Hex Nylock 3/8-16	69	HA20942	1	Decal
24	HA20170	1	Grip, Handle	70	HA5713	1	Spacer
25	49152	2	Rivet, Pop	71	HA15200	2	Washer
26	HA20134	1	Belt Guide & Idler Mounting Bracket	72	712-0261	1	Nut, Hex 5/18-11 Nylock
27	47630	4	Screw, 5/16-18 x 3/4" Self Tap	73	HA7974	2	Spacer
28	43661	5	Bolt, 1/4-20 x 1" Hex Head	74	48278	1	Bolt, Hex 5/8-11 x 7-1/2"
29	HA20185	1	Key, Woodruff No. 61	75	43010	6	Pin - 1/8" x 1-1/4" Cotter
30	24863	1	Cover, Drive	76	HA20688	1	Rod - Lift
31	67558	1	Transmission - Complete	77	HA19649	1	Anchor - Adjustment
32	24843	1	Chassis, Left	78	HA120396	1	Washer, 17/32" x 1-1/6" x .095" Flat
33	HA20186	1	Spring, Extension	79	40699	1	Plastic Tie w/ #8 Screw Hole
34	24844	1	Chassis, Right	80	HA456151	4	Washer, 13/16" x 1-1/2" x .134" Flat
35	26124	1	Bracket, Idler	81	HA20481	2	Pin - Hair Cotter
36	HA11496	1	Pulley, Idler	82	43070	16	Washer, 3/8"
37	HA20187	1	V-Belt	83	43012	3	Hex Bolt, 1/4-20 x 3/4"
38	47598	8	Washer Faced Lock Nut, 1/4-20	84	43178	1	Nut, 1/4-20 Hex
39	66397	1	Module	85	HA20692	1	Hitch Tube Assem. (incl. with #10)
40	43182	1	Hex Bolt, 5/16-18 x 3/4"	86	R19212113	1	Washer, 5/8"
41	26559	1	Hitch Bracket Extension	87	43346	1	Slot Truss Bolt, 10-32 x 5/8"
42	714-0117	1	Pin - Hair Cotter 5/32"	88	47171	1	Nylock Nut, 10-32
43	26366	1	Fender Plate	89	40710	1	Screw, 8-32 x .625
44	43910	2	#10 Washer		40907	1	Owner's Manual
45	43351	1	Bolt, Hex 1/2-13 x 1-1/4"				

***SpeedEPart*** *the fastest way to purchase parts* [www.speedepart.com](http://www.speedepart.com)

**REPAIR PARTS**

Agri-Fab, Inc.  
809 South Hamilton  
Sullivan, IL. 61951  
217-728-8388  
[www.agri-fab.com](http://www.agri-fab.com)