



JOHN DEERE

INSTALLATION INSTRUCTIONS

6 bu Material Collection System

LP77180
04/2022
English
Supplier ST48637

Introduction

Using Your Operator's Manual

Read this entire operator's manual, especially the safety information, before operating.

This manual is an important part of your machine. Keep all manuals in a convenient location so they can be accessed easily.

Use the safety and operating information in the attachment operator's manual, along with the machine operator's manual, to operate and service the attachment safely and correctly.

If your attachment manual has a section called Preparing the Machine, it means that you will have to do something to your tractor or vehicle before you can install the attachment. The Assembly and Installation sections of this manual provide information to assemble and install the attachment to your tractor or vehicle. Use the Service section to make any needed adjustments and routine service to your attachment.

If you have any questions or concerns with the assembly, installation, or operation of this attachment, see your local John Deere dealer or call the John Deere Customer Contact Center at 1-800-448-9282 for assistance.

Warranty information for this John Deere attachment can be found in the warranty statement included in this manual.

Original instructions. All information, illustrations and specifications in this manual are based on the latest information available at the time of publication.

The right is reserved to make changes at any time without notice.

NOTE: Retain these installation instructions with the machine operators manual.

Table of Contents

| | |
|----------------------------|-----|
| Introduction | 2 |
| Product Compatibility..... | 2 |
| Safety | 3-4 |
| Parts in Kit | 5 |
| Assembly | 6 |
| Installation | 7 |
| Operation..... | 7 |
| Specifications | 7 |
| Good Quality Service..... | 8 |
| Warranty | 12 |

Product Compatibility

The MCS 6 unit replace the bags on John Deere Material Collection Systems and allows the user to quickly and cleanly dump grass clippings onto a pile. This Material Collection System is compatible with all 6.5 bushel 2 bag units for the 100 series tractors starting model year 2021. Fits on Deere collection system attachment numbers BUC10284, BUC10286 and BUC10288.

Safety

Read Safety in Machine Operator's Manual

Read the general safety operating precautions in your machine operator's manual.

- The MCS is limited to carrying only grass or leaves.
- Be aware when maneuvering your machine because the MCS increases vehicle length.
- DO NOT allow anyone to ride in the MCS unit.
- Be aware of the potential pinch point when closing the tailgate.

Operating Safety

- Read the machine and attachment operator's manual carefully. Be thoroughly familiar with the controls and the proper use of the equipment. Know how to stop the machine and disengage the controls quickly.
- This attachment is intended for use in property maintenance applications. Do not use for use other than intended by the manufacturer. Do not modify machine or safety devices. Unauthorized modifications to the machine or attachment may impair its function and safety.
- Do not let children or an untrained person operate machine.
- Make any necessary adjustments before you operate. Never attempt to make any adjustments while the engine is running, unless it is recommended in adjustment procedure.
- Look behind machine before you back up. Back up carefully.
- Never carry passengers, especially children, on machine or attachment. Riders are subject to injury such as being struck by foreign objects and being thrown off. Riders may also obstruct the operator's view, resulting in the machine being operated in an unsafe manner.
- Disengage any power to the attachment when the machine is transported or not in use.
- Never exceed 15 mph when loaded spreader is attached to vehicle. Braking distances may be increased and handling characteristics may be impaired at speeds above 15 mph.
- Never use wet materials or materials with foreign debris in the spreader. This unit is designed to spread dry, clean, free-flowing material.
- Never leave material in hopper when not in use.
- Never lubricate, service or adjust the machine or

attachment while it is moving. Keep safety devices in place and in working condition. Keep hardware tight.

- Keep hands, feet, clothing, jewelry, and long hair away from any moving parts, to prevent them from getting caught.
- Lower any attachment completely to the ground or to an existing attachment mechanical stop before servicing the attachment. Disengage all power and stop the engine. Lock park brake and remove the key. Let machine cool.
- Disconnect the negative battery cable(s) before making any repairs.
- Before servicing machine or attachment, carefully release pressure from any components with stored energy, such as hydraulic components and springs.
- Release hydraulic pressure by lowering attachment or cutting units to the ground or to a mechanical stop and move hydraulic control levers.
- Securely support any machine or attachment elements that must be raised for service work. Use jack stands or lock service latches to support components when needed.
- Never run engine unless park brake is locked.
- Keep all parts in good condition and properly installed. Fix damage immediately. Replace worn or broken parts. Replace all worn or damaged safety and instruction decals.
- Check all hardware at frequent intervals to be sure the equipment is in safe working condition.
- Do not modify machine or safety devices. Unauthorized modifications to the machine or attachment may impair its function and safety.

Parking Safely

1. Stop vehicle on a level surface, not on a slope.
2. Fully lower the cargo box and any attachments on the machine that can be lowered.
3. Fully engage the parking brake and ensure vehicle is not moving.
4. Stop engine.
5. Remove key.
6. Disconnect the negative battery cable before servicing the machine.

Safety

Wear Appropriate Clothing

- Always wear eye protection when operating the machine.
- Wear close fitting clothing and safety equipment appropriate for the job.
- While operating this machine, always wear substantial footwear and long trousers. Do not operate the equipment when barefoot or wearing open sandals.
- Wear a suitable protective device such as earplugs. Loud noise can cause impairment or loss of hearing.
- Always wear substantial footwear. Do not operate the equipment when barefoot or wearing open sandals.



Read Chemical Container Label

- Chemicals can be dangerous. Improper selection or use can injure persons, animals, plants, soils or other property. Select the right chemical for the job and handle and apply with care.
- Read the instructions, precautions, and warnings on the container label before opening. Use the product strictly according to label directions for specific applications, in the amounts specified, at the times specified and only when needed.
- Do not remove labels from chemical containers. Store all chemicals in their original containers.
- Do not mix chemicals unless stated on the container label.
- Store chemicals when not in use according to the container label.

Handle Chemical Products Safely

- Direct exposure to hazardous chemicals can cause serious injury. Potentially hazardous chemicals used with John Deere equipment include pesticides, herbicides and fungicides.
- A Material Safety Data Sheet (MSDS) provides specific details on chemical products: physical and health hazards, safety procedures, and emergency response techniques.
- The MSDS should be obtained from the chemical dealer at the time of the chemical purchase.
- Check the MSDS before beginning any job using a hazardous chemical. Know exactly what the risks are and how to do the job safely. Always wear recommended personal protection equipment.

Handling Waste Product and Chemicals

- Waste products, such as used oil, fuel, coolant, brake fluid, and batteries, can harm the environment and people.
- Do not use beverage containers for waste fluids - someone may drink from them.
- See your local Recycling Center or authorized dealer to learn how to recycle or get rid of waste products.
- A Material Safety Data Sheet (MSDS) provides specific details on chemical products: physical and health hazards, safety procedures, and emergency response techniques. The seller of the chemical products used with your machine is responsible for providing the MSDS for that product.

Parts in Kit

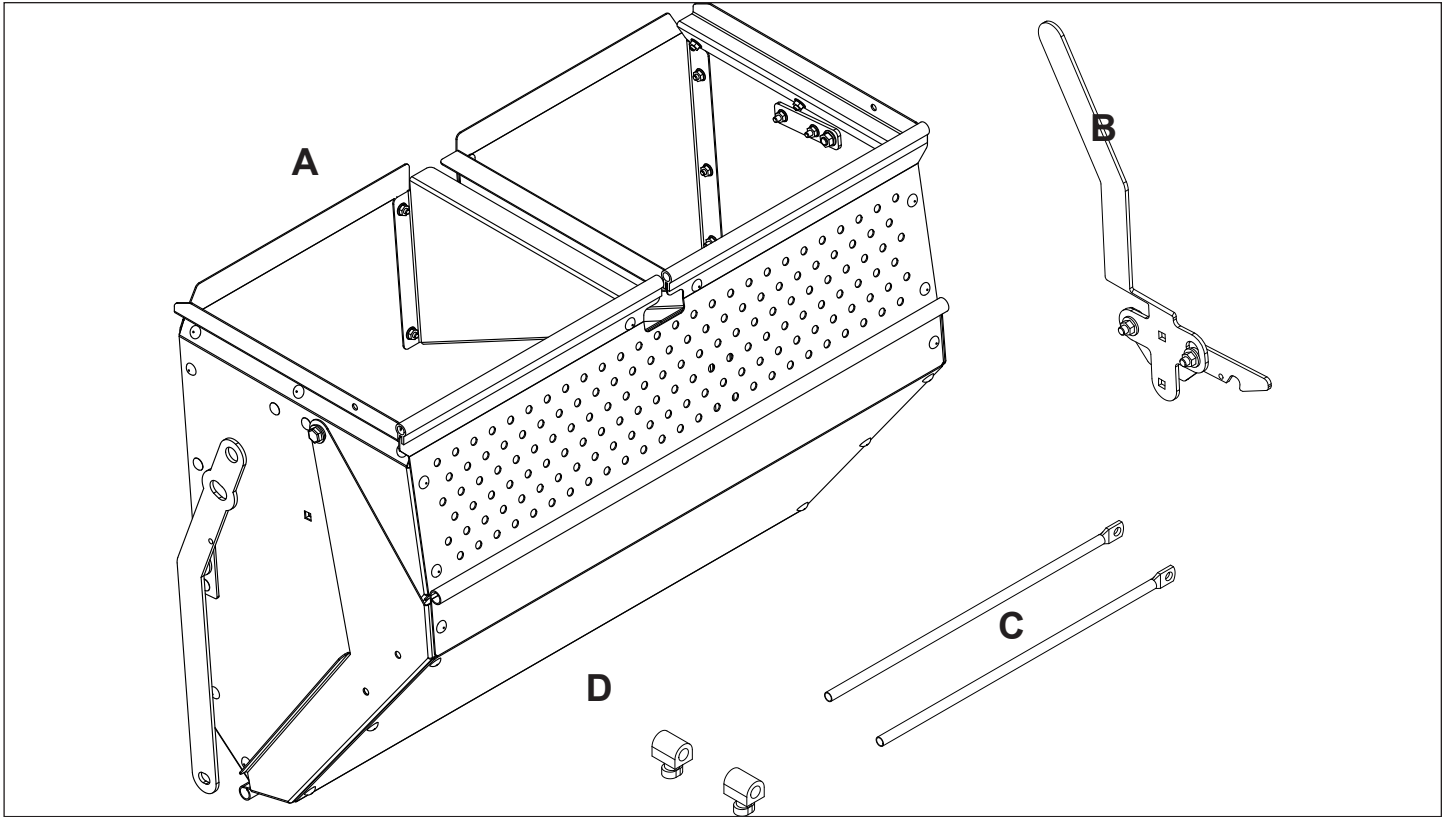

Main Components

| Description | Letter | Qty |
|---------------------------|--------|-----|
| MCS Bin Assembly | A | 1 |
| Handle and Latch Assembly | B | 1 |
| Lift Link | C | 2 |

Hardware

| Description | Letter | Qty |
|-------------------------|--------------|-----|
| Adjustment Link | D | 2 |
| 3/8" x 1" Carriage Bolt | Hardware bag | 2 |
| 3/8" Nylock Nut | Hardware bag | 2 |
| 3/8" Plastic Washer | Hardware bag | 2 |
| 3/8" Flat Washer | Hardware bag | 4 |
| 3/8" Jam Nut | Hardware bag | 4 |
| 3/8" x 1- 3/4" Bolt | Hardware bag | 1 |
| 3/8" Flange Nut | Hardware bag | 1 |
| Spring | Hardware bag | 1 |
| Steel bushing | Hardware bag | 1 |
| 5/16" x 1 3/4" Bolt | Hardware bag | 2 |
| 5/16" Flange Nut | Hardware bag | 4 |
| 1/4" x 3/4" Clevis Pin | Hardware bag | 1 |
| Bowtie Clip | Hardware bag | 1 |

Assembly

Assemble the Hopper

1. Place 3/8" Washer (C), Steel Bushing (A), and another 3/8" Washer (C) over 3/8" x 1-3/4" Bolt (B) and insert it into hole (D). Fasten on the inside with a 3/8" Flange Nut.

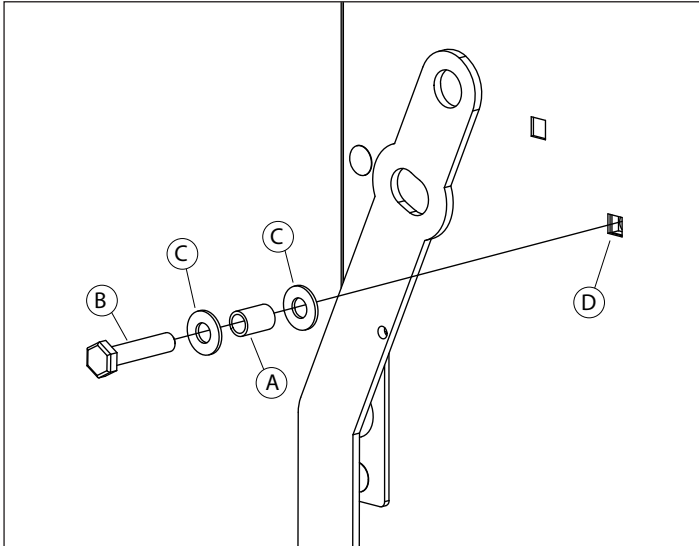

2. Install Handle (E) using two 3/8" x 1" Carriage Bolts (F), two 3/8" Plastic Washers (G), two 3/8" Wide Flat Washers (H), and two 3/8" Nylock Nuts (J) as shown

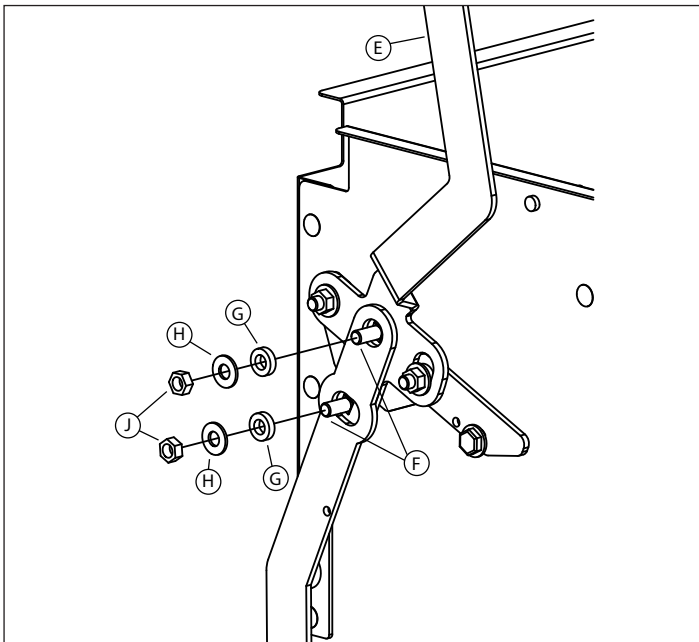

3. Connect Spring (K) from hole (L) in latch to hole (M) in lever.

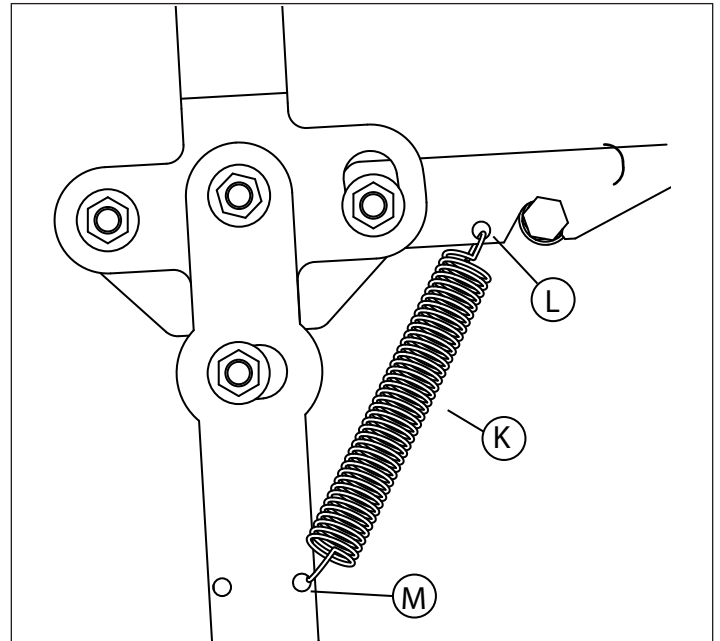

4. On threaded end of Lift Links (P), turn on one 3/8" Jam Nut (N) to the end of the threads. Insert the threads through the Adjustment Link (Q) and put another 3/8" Jam Nut (N) on the end. Do not tighten
5. Insert 5/16" x 1-3/4" Bolt (R) through hole on other side of Lift Link (P) and thread a 5/16" Flange Nut (S) to the end of the threads with the flange facing away from the Lift Link

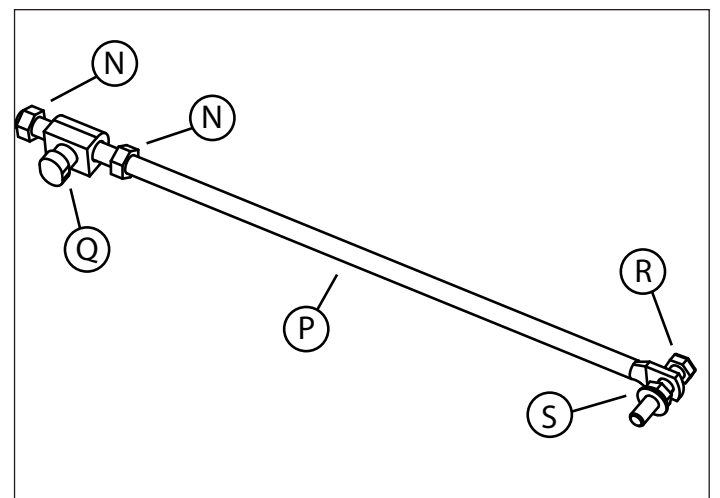

Installation

6. Insert the Adjustment Link (T) through the slot in the lever. Rotate Lift Link to put bolt through the hole (U) in the side of the tailgate. Fasten inside with 5/16" Flange Nut.
7. With the Handle latched, tighten 3/8" Jam Nut (W) until there is no gap between the bin and the tailgate (at location X). Then tighten Nut (Y) back against the Adjustment Link to jam it in place.

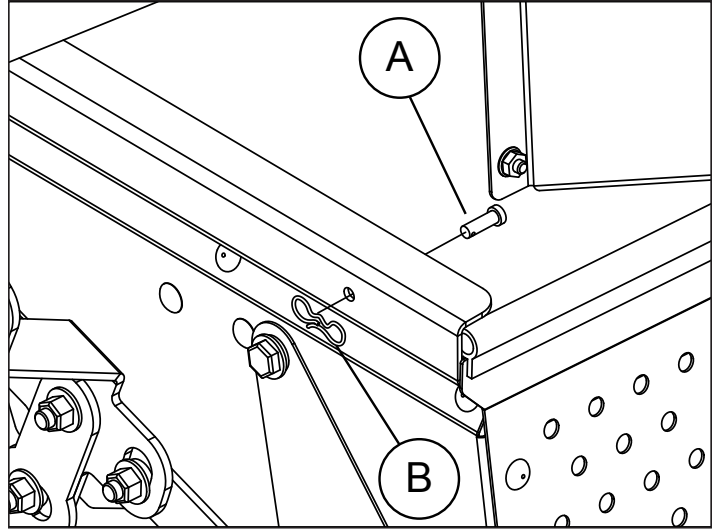
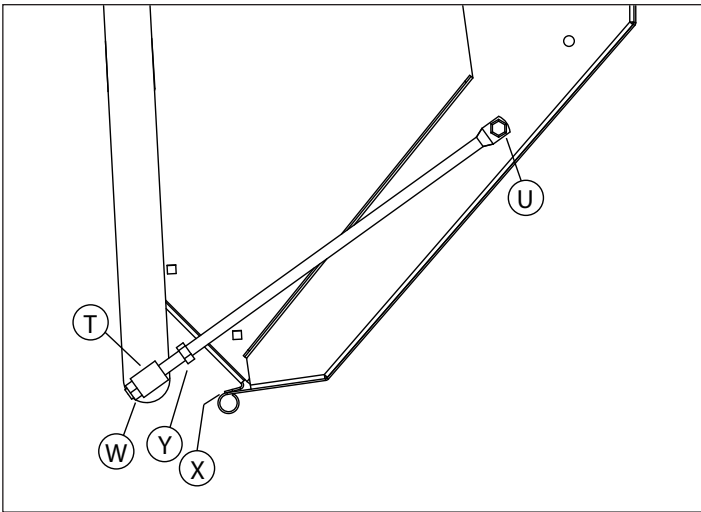

CAUTION: Avoid injury! Be aware of the potential pinch point when closing the tailgate

Preparing the Machine

1. Open the hood and remove bags. Lift the bin and slide the side rails into the channels on the bag frame with the center support of the bin on top of the center T on the frame.

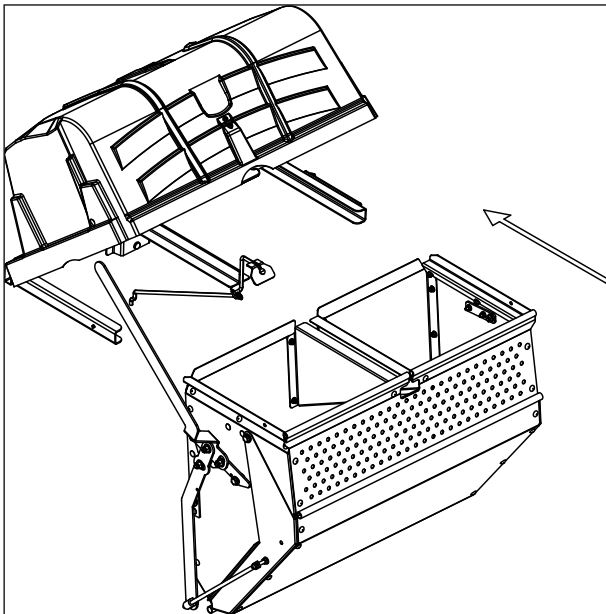

2. Use 1/4" x 3/4" clevis pin (A) and bowtie clip (B) to secure bin on left side.

Operation

To empty the bin, pull the lever and drive slowly forward until empty. Push lever back firmly until it latches.



IMPORTANT: Avoid Damage! The MCS is limited to carrying only grass or leaves

Removal

1. Park machine safely.
2. Open the hood lift the bin and pull it towards you.

Specifications

MCS

| | |
|-----------------|-------------------------------|
| Hopper Capacity | Volume 169 L 6 bu (7.4 cu ft) |
| Hopper Material | Aluminum |

Dimensions

| | |
|--------|----------------|
| Length | 17 in (432 mm) |
| Width | 38 in (965 mm) |
| Height | 25 in (635 mm) |

Weight

| | |
|-------|----------------|
| Empty | 36 lbs (16 kg) |
|-------|----------------|

Good Quality Service

John Deere Quality Continues with Quality Service

John Deere provides a process to Handle your questions or problems, should they arise, to ensure that product quality continues with quality parts and service support.

Follow the steps below to get answers to any questions you may have about your product.

Refer to your attachment and machine operator manuals.

In North America or Canada, call John Deere Special Services at 1-800-448-9282 and provide product serial number (if available) and model number.

Warranty

Limited Warranty for New John Deere Licensed Products

Agri-Fab's attachments are guaranteed to be free from defects in material and workmanship from the date of purchase for 1 year residential use, 6 months commercial use, provided that the purchaser properly assembles, installs, uses and maintains the products in accordance with this manual.

Purchaser's failure to adhere to such requirements will void the warranty. To the extent permitted by applicable law, all other warranties, representations, obligations and conditions, expressed or implied, including but not limited to implied warranties of merchantability, fitness for any particular purpose and non-infringement, are hereby disclaimed and excluded.

Any product which does not meet warranty shall, as purchaser's sole and exclusive remedy, be repaired or replaced by Agri-Fab. This warranty is non transferable.

In addition, our warranty does not cover:

- Labor charges
- Loss or consequential, incidental or special damages of any kind

This product was manufactured by Agri-Fab, Inc, a John Deere Licensee. If you have any questions or concerns with the assembly, installation, or operation of this attachment, see your local John Deere dealer or call Agri-Fab at 1-800-448-9282 for assistance.

