



**JOHN DEERE**

**OPERATORS MANUAL**  
3 cu ft Gator Fertilizer Spreader

LP69910  
Supplier ST50946  
02/15/2021  
English

# Introduction

## Using Your Operator's Manual

Read this entire operator's manual, especially the safety information, before operating.

This manual is an important part of your machine. Keep all manuals in a convenient location so they can be accessed easily.

Use the safety and operating information in the attachment operator's manual, along with the machine operator's manual, to operate and service the attachment safely and correctly.

If your attachment manual has a section titled Preparing the Machine, it means that you will have to do something to your tractor or vehicle before you can install the attachment. The Assembly and Installation sections of this manual provide information to assemble and install the attachment to your tractor or vehicle. Use the Service section to make any needed adjustments and routine service to your attachment.

If you have any questions or concerns with the assembly, installation, or operation of this attachment, see your local John Deere dealer or call the John Deere Customer Contact Center at 1-888-867-2238 for assistance.

Warranty information for this John Deere attachment can be found in the warranty that came with your John Deere tractor or vehicle.

## Table of Contents

Introduction	2
Product Identification	2
Safety Labels	3
Safety	5
Assembly	7
Installation	8
Operation	9
Maintenance	15
Removal & Storage	16
Troubleshooting	17
Wiring Diagram	22
Specifications	23
Getting Quality Service	24
Warranty	25

## Product Compatibility

This attachment is compatible with John Deere Gator™ Utility Vehicles. Contact your John Deere dealer for specific utility vehicle compatibility information.

*Original instructions. All information, illustrations and specifications in this manual are based on the latest information available at the time of publication.*

*The right is reserved to make changes at any time without notice.*

**NOTE: Retain these installation instructions with the machine operators manual.**

# Safety Labels

## Safety Label Locations

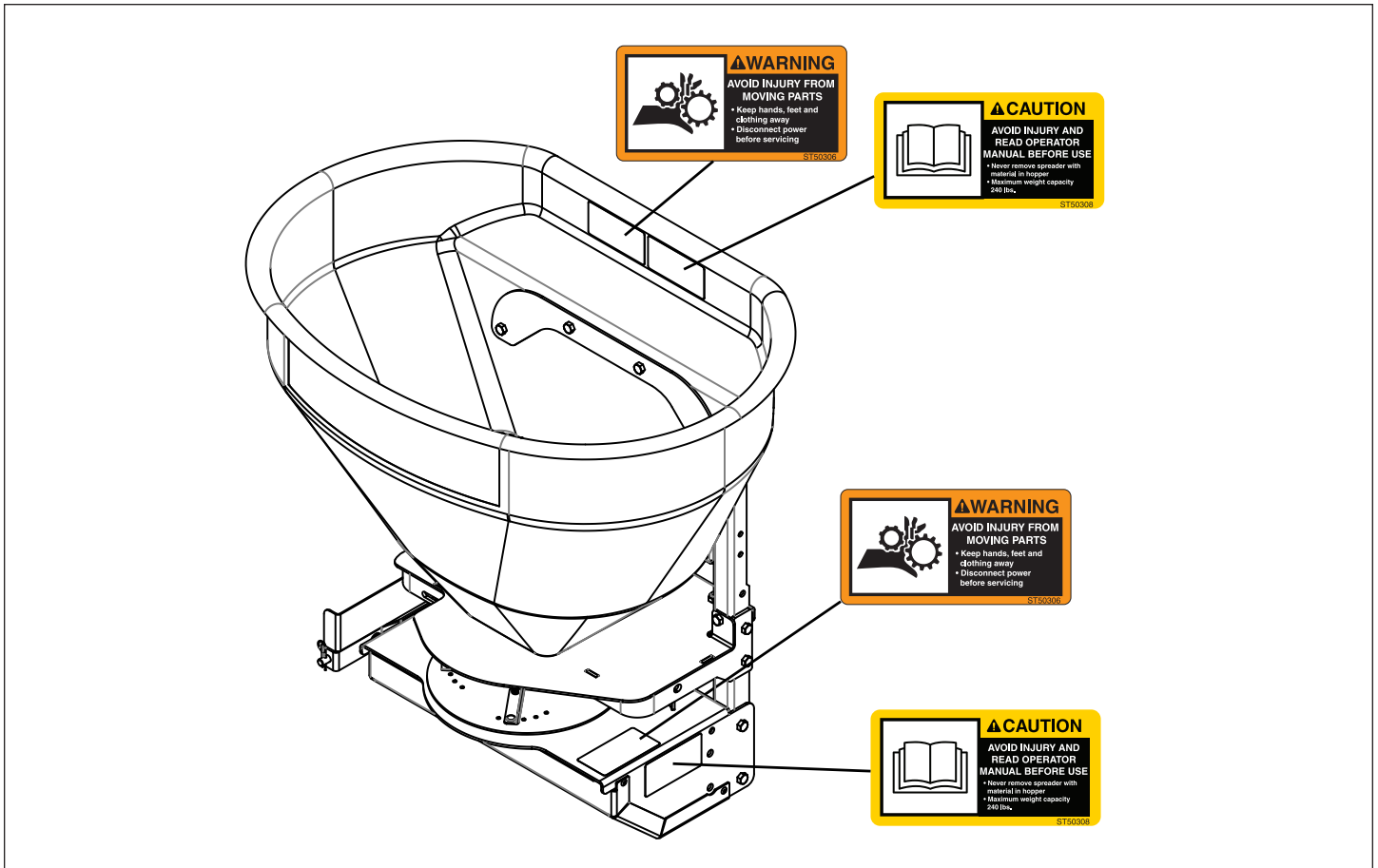

## Understanding The Machine Safety Labels



The machine safety labels shown in this section are placed in important areas on your machine to draw attention to potential safety hazards. DANGER or WARNING safety labels are located near specific hazards.

The operator's manual also explains any potential safety hazards whenever necessary in special safety messages that are identified with the word, CAUTION, and the safety-alert symbol.

On your machine safety labels, the words DANGER, WARNING, and CAUTION are used with this safety-alert symbol. DANGER identifies the most serious hazards:

- DANGER; The signal word DANGER indicates a hazardous situation which, if not avoided, will result in death or serious injury.
- WARNING; The signal word WARNING indicates a hazardous situation which, if not avoided, will result in death or serious injury.

- CAUTION; The signal word CAUTION indicates a hazardous situation which, if not avoided, could result in minor or moderate injury. CAUTION may also be used to alert against practices associated with events which could lead to personal injury.

Replace missing or damaged safety labels. Use this operator's manual for correct safety label placement.

There can be more safety information contained on parts and components sourced from suppliers that is not reproduced in this operator's manual.

## French or Spanish Safety Labels and Operator's Manual

Operator's manuals and safety labels with content in French or Spanish are available for this machine through authorized John Deere dealers. See your John Deere dealer.

**NOTE: Both text and no-text labels are shown. Your machine is only equipped with one of these types of labels.**

# Safety Labels

## WARNING

### AVOID INJURY FROM MOVING PARTS

- Keep hands, feet and clothing away
- Disconnect power before servicing



## CAUTION

### AVOID INJURY AND READ OPERATOR MANUAL BEFORE USE

- Never remove spreader with material in hopper
- Maximum weight capacity 240 lb.



# Safety

## Read Safety in Machine Operator's Manual

Read the general safety operating precautions in your machine operator's manual.

## Operating Safety

- Read the machine and attachment operator's manual carefully. Be thoroughly familiar with the controls and the proper use of the equipment. Know how to stop the machine and disengage the controls quickly.
- This attachment is intended for use in property maintenance applications. Do not use for use other than intended by the manufacturer. Do not modify machine or safety devices. Unauthorized modifications to the machine or attachment may impair its function and safety.
- Do not let children or an untrained person operate machine.
- Make any necessary adjustments before you operate. Never attempt to make any adjustments while the engine is running, unless it is recommended in adjustment procedure.
- Look behind machine before you back up. Back up carefully.
- Never carry passengers, especially children, on machine or attachment. Riders are subject to injury such as being struck by foreign objects and being thrown off. Riders may also obstruct the operator's view, resulting in the machine being operated in an unsafe manner.
- Disengage any power to the attachment when the machine is transported or not in use.
- Never exceed 15 mph when loaded spreader is attached to vehicle. Braking distances may be increased and handling characteristics may be impaired at speeds above 15 mph.
- Never use wet materials or materials with foreign debris in the spreader. This unit is designed to spread dry, clean, free-flowing material.
- Never leave material in hopper when not in use.
- Weight of mounted machines, including their loads, can influence vehicle maneuverability. Refer to vehicle OM for ballasting.
- Do not operate the engine in a confined space where dangerous carbon monoxide fumes can collect.
- Never lubricate, service or adjust the machine or attachment while it is moving. Keep safety devices in place and in working condition. Keep hardware tight.
- Keep hands, feet, clothing, jewelry, and long hair away from any moving parts, to prevent them from getting caught.
- Lower any attachment completely to the ground or to an existing attachment mechanical stop before servicing the attachment. Disengage all power and stop the engine. Lock park brake and remove the key. Let machine cool.
- Disconnect the negative battery cable(s) before making any repairs.
- Before servicing machine or attachment, carefully release pressure from any components with stored energy, such as hydraulic components and springs.
- Release hydraulic pressure by lowering attachment or cutting units to the ground or to a mechanical stop and move hydraulic control levers.
- Securely support any machine or attachment elements that must be raised for service work. Use jack stands or lock service latches to support components when needed.
- Never run engine unless park brake is locked.
- Keep all parts in good condition and properly installed. Fix damage immediately. Replace worn or broken parts. Replace all worn or damaged safety and instruction decals.
- Check all hardware at frequent intervals to be sure the equipment is in safe working condition.
- Do not modify machine or safety devices. Unauthorized modifications to the machine or attachment may impair its function and safety.

## Practice Safe Maintenance

- Only qualified, trained adults should service this machine.
- Understand service procedure before doing work. Keep area clean and dry.

# Safety

## Parking Safely

1. Stop vehicle on a level surface, not a slope.
2. Fully lower the cargo box and any attachments on the machine that can be lowered.
3. Fully engage parking brake and ensure vehicle is not moving.
4. Stop engine.
5. Remove key.
6. Before you leave the operator's seat, wait for the engine and all moving parts to stop.
7. Disconnect the negative battery cable before servicing the machine.

## Wear Appropriate Clothing

- Always wear eye protection when operating the machine.
- Wear close fitting clothing and safety equipment appropriate for the job.
- While operating this machine, always wear substantial footwear and long trousers. Do not operate the equipment when barefoot or wearing open sandals.
- Wear a suitable protective device such as earplugs. Loud noise can cause impairment or loss of hearing.
- Always wear substantial footwear. Do not operate the equipment when barefoot or wearing open sandals.

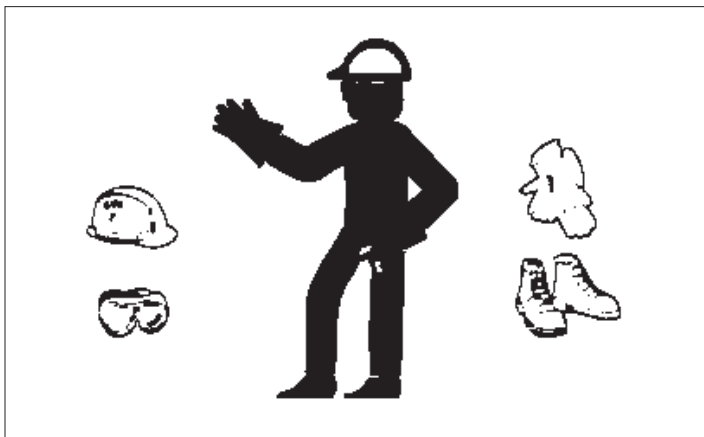

## Read Chemical Container Label

- Chemicals can be dangerous. Improper selection or use can injure persons, animals, plants, soils or other property. Select the right chemical for the job and handle and apply with care.
- Read the instructions, precautions, and warnings on the container label before opening. Use the product strictly according to label directions for specific applications, in the amounts specified, at the times specified and only when needed.

- Do not remove labels from chemical containers. Store all chemicals in their original containers.
- Do not mix chemicals unless stated on the container label.
- Store chemicals when not in use according to the container label.

## Handle Chemical Products Safely

- Direct exposure to hazardous chemicals can cause serious injury. Potentially hazardous chemicals used with John Deere equipment include pesticides, herbicides and fungicides.
- A Material Safety Data Sheet (MSDS) provides specific details on chemical products: physical and health hazards, safety procedures, and emergency response techniques.
- The MSDS should be obtained from the chemical dealer at the time of the chemical purchase.
- Check the MSDS before beginning any job using a hazardous chemical. Know exactly what the risks are and how to do the job safely. Always wear recommended personal protection equipment.

## Handling Waste Product and Chemicals

- Waste products, such as used oil, fuel, coolant, brake fluid, and batteries, can harm the environment and people.
- Do not use beverage containers for waste fluids - someone may drink from them.
- See your local Recycling Center or authorized dealer to learn how to recycle or get rid of waste products.
- A Material Safety Data Sheet (MSDS) provides specific details on chemical products: physical and health hazards, safety procedures, and emergency response techniques. The seller of the chemical products used with your machine is responsible for providing the MSDS for that product.

# Assembly

## Parts in Kit

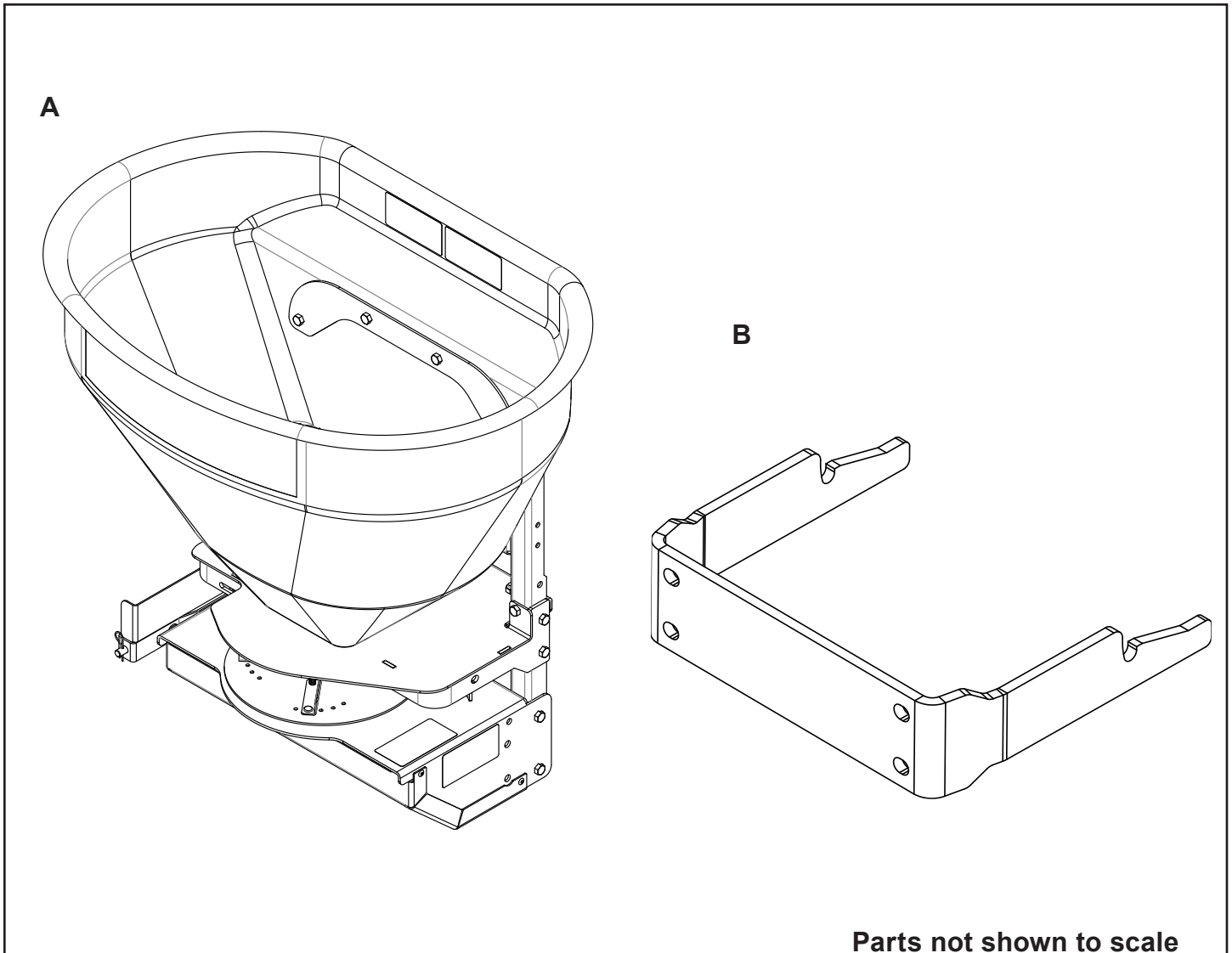

Description	Letter	Qty
Spreader	A	1
Hitch Mount	B	1
Hopper Cover	Not Shown	1
Spreader Harness	Not Shown	1
1/2 in. x 1-1/2 in. Flange Bolts	Not Shown	4
Receptacle Dust Cap	Not Shown	1



# Installation

## Spreader Assembly

1. Connect hitch mount (A) to the spreader using four 1/2 in. x 1- 1/2 in. flange bolts (B).

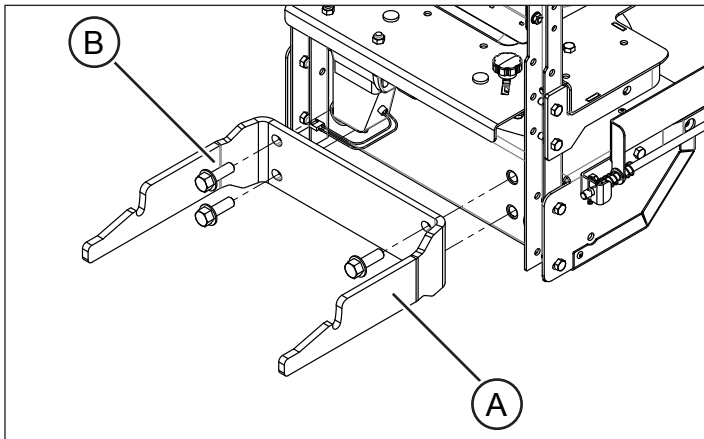

2. For use with 835/865 Gator, remove CAN termination plug (C) from spreader harness and replace with receptacle dust cap (D).

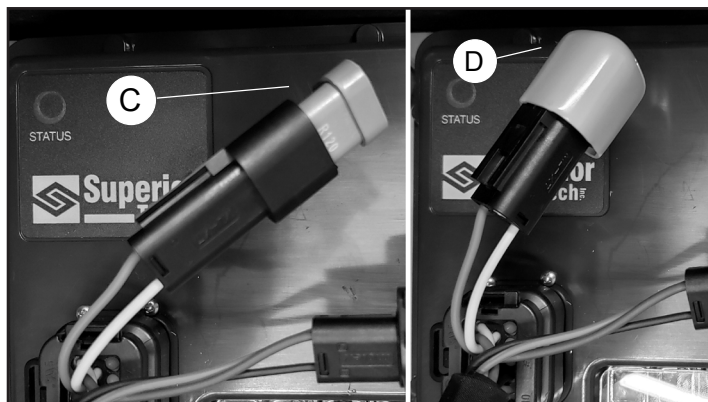

## Installing Spreader

1. To aid in assembly, add grease to the slots.

**NOTE:** It is recommended that two people lift the spreader for this installation.

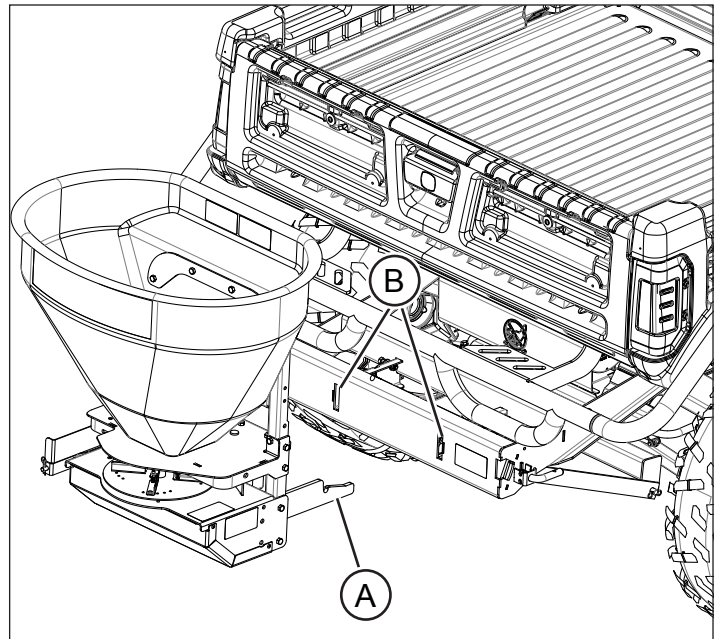

2. Side receiver arms (A) into slots (B) until it clicks to lock into place. Be sure that the hitch latches securely.

3. Plug the spreader harness into the chassis harness (C). Secure the harness to the hitch using the harness clips (D).

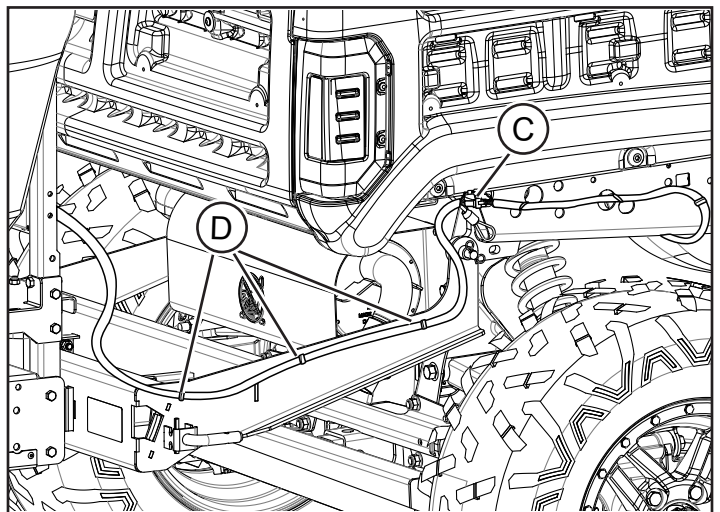



# Operation

## Determine Vehicle Load Capacity

Use the vehicle's Operator's Manual to determine vehicle load capacity.



**CAUTION: Avoid Injury! Overloading the vehicle causes loss of control and causes serious injury or death.**

- Do not allow the Gross Vehicle Weight (GVW) to exceed the Gross Vehicle Weight Rating (GVWR) of the vehicle.
- Remove excess weight before operating vehicle.

**Note: Optional equipment and attachments that are not standard equipment reduce your cargo box capacity; so they must be included when determining gross vehicle weight.**

## Use Correct Tires and Inflation

See specification section of this operators manual for spreader weight



**CAUTION: Help prevent severe bodily injury or death, failure to observe the recommendations in the vehicle operator's manual may result in loss of stability and operator control.**

See tire descriptions and inflation pressures for load conditions in the specifications section of the vehicles operator's manual.

## Spreader Components

Hopper	3 cu. ft. capacity, high density polypropylene molded hopper
Spinner Motor	Variable speed 12V DC motor drives a 12in spinner disk to distribute material
Gate Motor	12V DC Actuator controls the gate
Controller	12V DC motor driver controls the spinner, and motor
Display	2.4 in. monochrome OLED with 7 buttons

## Spreader Features

Electric gate control (Open/Close)
Variable speed spinner for spread width control
Adjustable spread pattern for various materials
Barrier shield
Detailed error/diagnostic message

## Turning On Display



The vehicle key must be in the "On" or "Run" position for the display to turn on.

When turned on, a splash screen will appear as the software loads. The operation page will appear when loading is complete. The spreader is now ready to operate.

## Navigation

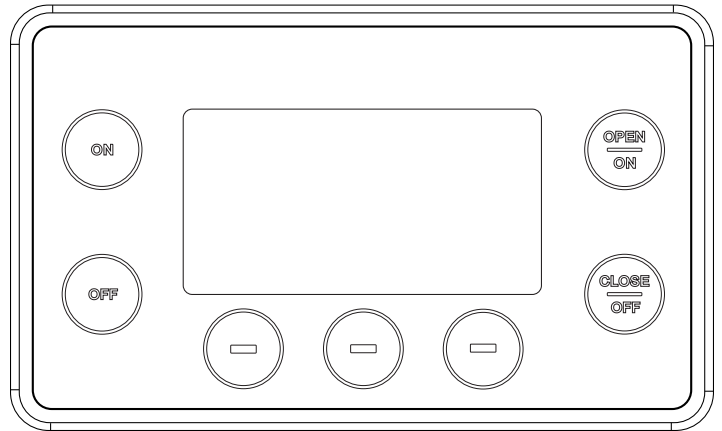
Control the spreader using the buttons on the display. Button functionality is described in the table below and varies by screen.



Button #	Button Functions		
1	ON	Spinner/Auger On	Press the "ON" button to turn on the spinner.
2	OFF	Spinner/Auger Off	Press the "OFF" button to turn off the spinner.
3	OPEN/ON	Gate Open/Vibe ON	Press the "OPEN" button to open the gate /  Press the "ON" button to turn on the vibe.
4	CLOSE/OFF	Gate Close/Vibe OFF	Press the "CLOSE" button to close the gate /
5		Down Arrow	Press to decrease the speed of the spinner/ auger.
6		Up Arrow	Press to increase the speed of the spinner/ auger.
7	MENU	Menu Button	Press to enter the menu.

# Operation

From the operation page, an operator can power on the spreader, enter the menu, or spinner speed.

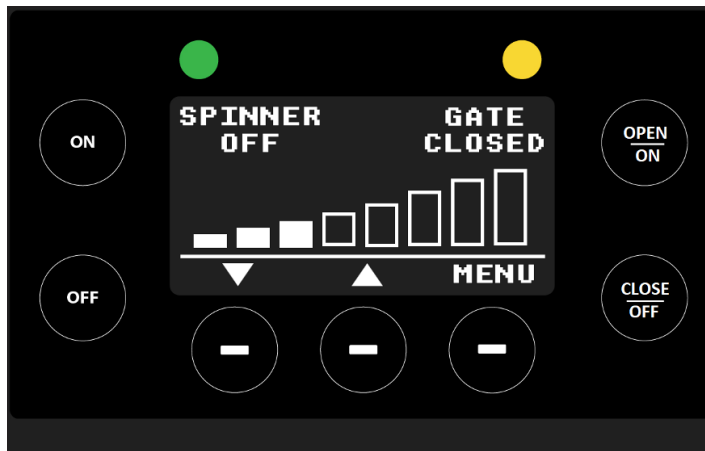

## Main Menu

Pressing the menu button will enter the main menu.

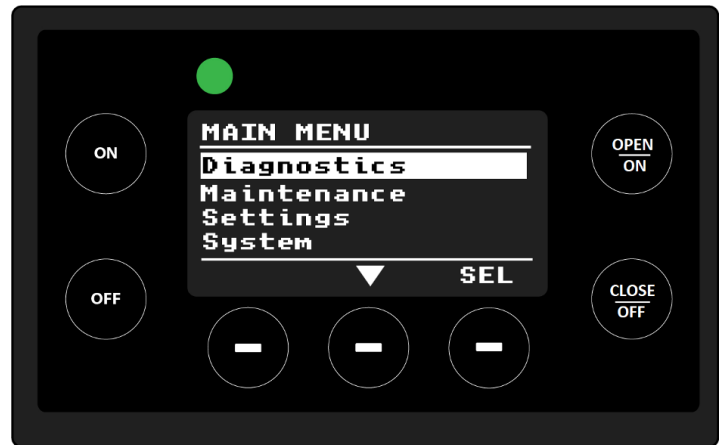

Once in the main menu, the user can select the following:

### Default Motor Controls

Starting and Stopping Spreader	<p>Press the ON button to turn on the spinner/auger.</p> <p>Press the OFF button to turn off the spinner/auger</p>
Gate/Vibe Control	<p>Press the OPEN/ON button to open the gate or to turn on the vibe.</p> <p>Press the CLOSE/OFF button to close the gate or to turn off the vibe.</p>
Adjusting Motor Speed	<p>Press the bottom left button (down arrow) to decrease the speed of the motor in 11% increments.</p> <p>Press the bottom mid button (up arrow) to increase the speed of the motor in 11% increments.</p>
Entering the Menu	<p>Press the bottom right button (menu) to enter the menu.</p>

**NOTE:** In order to control the Gate/Vibe motor the Spinner/Auger must be active, if it is not active the Gate/Vibe label state will blink indicating the motor is disabled.

### Menu Options

Menu Options	
Diagnostics	Review the warning and fault list.
Maintenance	Displays maintenance menu with options to reverse auger.
Settings	Adjusts the parameters of the display.
System	Display system's voltage and temperature.
Support	Displays support information.
Controller Info	Displays controller information
Display Info	Displays system information.
Exit	Returns to the home page.

### Settings Menu

Selecting settings from the main menu will enter the settings menu.

From the settings menu, the user can select the following:

- Display to select the brightness level.
- CAN, to enable/disable the CAN terminator resistor.
- Exit, go back to main menu.

# Operation

## Display Screen Messages

During operation a message may appear describing a potential issue or problem.

Motor Over Current	<p>A motor is drawing too much current. Spreader will shut down, display an error message, and prompt the operator to reset the spreader.</p> <p>The spinner disk may be jammed and needs to be cleared.</p>
Motor Open Circuit	<p>This message is displayed when a motor is disconnected. Ensure that all harnesses are installed correctly, and connectors are fully seated. Ensure that the status light on the motor controller is green.</p>
Voltage High	<p>This message is displayed when the controller is receiving a voltage higher than 16V. Please check battery voltage.</p>
Voltage low	<p>This message is displayed when the controller is receiving a voltage lower than 9V. Please check battery voltage.</p>
No Comm	<p>This message is displayed when there is a loss of communication with the motor controller. Ensure that all harnesses are installed correctly, and connectors are fully seated. Ensure that the status light on the motor controller is green.</p>

# Operation

## Spreading

**NOTE:** Always use the hopper cover to prevent moisture buildup. Do not let spreader sit idle with material in the hopper for an extended period of time. This can cause material to compact, reduce or stop the flow of material and cause permanent hopper damage.



**IMPORTANT:** Never operate near pedestrians. Never exceed 10 mph while spreading. This spreader is for fertilizer only. Not recommended for use with rock salt.



**CAUTION:** DO NOT leave unused material in hopper. Material can freeze or solidify, causing unit to not work properly. Empty and clean after each use.



**CAUTION:** Disconnect electric and/or hydraulic power and tag out if required before servicing or performing maintenance.

The fertilizer spreader is for finer materials. Do not use spreader for rock salt. Recalibrate when switching between materials.

- To adjust spread width, increase/decrease spinner speed.
- To adjust application rate, increase/decrease gate opening or vehicle speed.

The adjustable fin (A) provides a way to adjust spread patterns with different materials. Select the desired position by lifting the outside top edge (B). Different materials act in different ways in relation to spinner speed. Moving the fins corrects most pattern issues without having to sacrifice spinner speed. All adjustments must be made on pavement and positions noted for future reference. Incorporate adjustments into your normal calibration process.

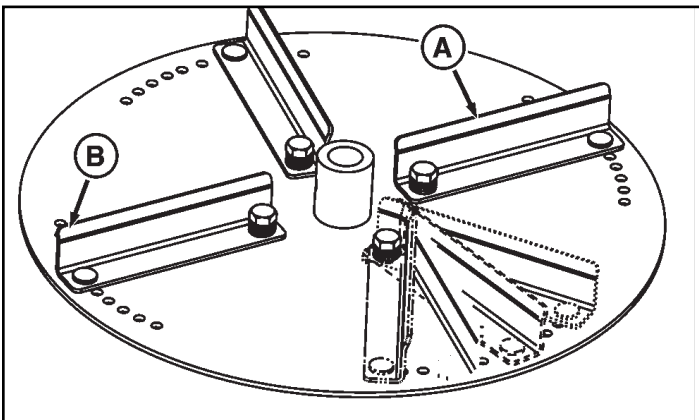

1. To change the material flow rate, adjust the gate stop bolt. Loosen knob (C) and reposition in the slot.

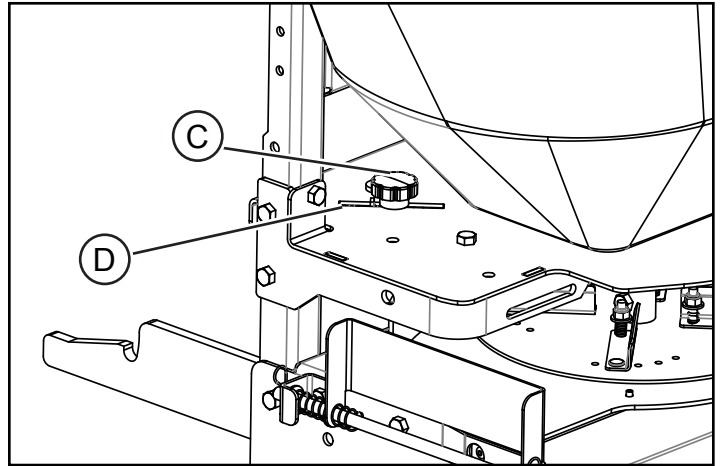

2. Position the knob in the end of the slot at position (D) for maximum material output.

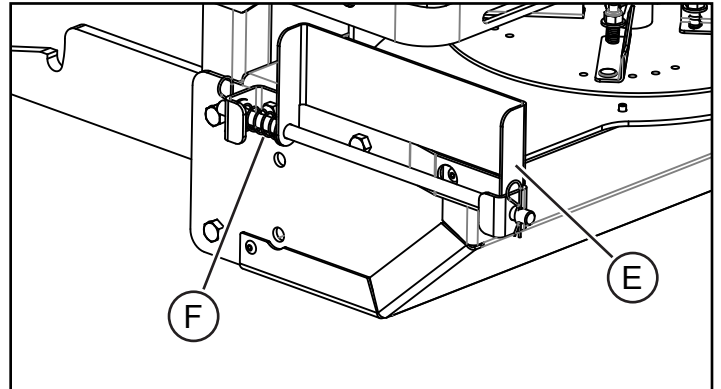

3. The barrier shield (E) comes installed on the left side of the fertilizer spreader. To raise or lower the shield, push it against the spring (F) and rotate.

# Operation

## Fertilizer Spreader Calibration

It is the responsibility of the person using this equipment to make sure that every type of material is properly calibrated to perform as expected. To achieve a safe and accurate reading for proper material distribution, calibration must take place on a solid flat surface away from drains and livestock areas. Failure to do so causes an over or under application that damages turf areas or gives an ineffective pest control treatment. Any calibration charts contained in this manual are given as a reference point only and must not be used as an absolute condition. Spending a few extra minutes to calibrate not only saves on wasted materials and time, but also protects turf and other vegetation. Be aware of the following points before operating your spreader in the field.

### Flow Rates

Flow rates of materials change for many reasons:

- Formulations vary within the same brand or even between brands.
- Formulations vary between batches or dates of manufacture.
- Humidity causes the material to clump and flow poorly.
- Poor spreader maintenance causes flow changes.
- Slide stop has moved or has been calibrated to another type of material.
- Human error causes rate miscalculation.

### Items Needed for Calibration

- A way to catch the material for weighing.
- A device to measure distance.
- A scale to weigh your product.
- A stop watch or other device to measure time.

### Conversion

To convert pounds per 1000 sq. ft. to pounds per acre, multiply your rate by 43.6. To convert miles-per-hour to feet-per-minute, multiply miles-per-hour by 88.

Other Important Information:

1 acre is equal to 43,560 sq. ft. Ground speed is important to keep in mind when doing calculations, convert miles-per-hour to feet-per-minute.

## Calibration

**NOTE: To change the spread pattern, adjust the spinner fins.**

To calibrate the spreader, use a level, open area of pavement. Set the gate stop in the middle as a starting point. Fill the hopper with the material desired. Turn on the spreader. To achieve desired spread width, adjust spinner speed. Record the spinner speed setting and the resulting spread width. Determine the driving speed while spreading (in feet-per-minute). Determine desired application rate (converted to pounds-per-square-foot). To determine the pounds-per-minute that the gate setting must allow, use the following equation.

Desired Application Rate (pounds-per-square-foot) x Spread Width (feet) x Speed (feet-per-minute) = Pounds-per-minute.

Open the gate. The spinner must be operating during this step. Put a bucket or other means of catching material at the back of the spreader. Leave the gate open for one minute. Brush off all excess from the spinner and motor enclosure into the bucket. Weigh the bucket with material. Subtract the weight of the bucket when empty and record. To achieve the required "pounds-per-minute" rate, adjust the gate based on the result. Once the setting is established, you are ready to spread. Record for future use on the notes page of this manual (example record: when spreading Material XYZ... Spinner speed 50% (width=14 ft.), Drive 3.5 mph (308 fpm), Gate = 13 in.).

Begin spreading with the vehicle speed, gate setting, and spinner speed used in your calculations.

# Operation

		Materials					
	Gate Setting	UREA 46-0-0	Lesco Turface	Lesco Shade Mix	Lesco Fert. 30-0-10	Lesco Insecticide	
Key Settings	1	X	X	X	X	0.57	
	2	1.39	0.83	X	0.39	5.28	
	3	7.15	2.11	X	3.84	14.38	
	4	10.54	X	0.18	8.79	18.06	
	5	15.97	X	0.40	13.55	30.24	
	6	24.66	X	0.51	17.07	35.04	
	7	31.36	14.70	0.66	23.94	50.32	
	8	35.70	X	0.98	29.74	56.22	
	9	47.70	X	1.78	39.38	64.56	
	10	55.29	X	5.59	45.20	76.47	
	11	63.39	37.95	7.27	53.22	82.59	
	12	73.59	X	8.72	64.64	106.49	
	13	78.60	X	10.00	69.06	122.64	
	14	83.08	X	11.81	73.80	133.72	
	15	93.52	57.32	11.94	91.32	145.00	
Flow Rates Are Calculated at Pounds-Per-Minute							

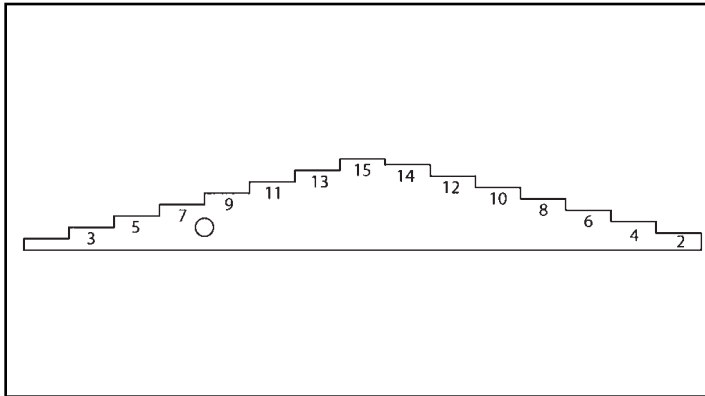

# Maintenance

## Routine Maintenance

To keep your spreader running smoothly, follow these recommendations.

- Wash out the hopper and rinse off all external surfaces after use.
- Apply dielectric grease on all electrical connection to prevent corrosion at the end of the season and each time electrical connections are unplugged.
- Clear away any material from the controller.
- Inspect electrical connections for debris and clean before connecting.



# Removal and Storage

## Removal



**CAUTION: Disconnect electric and/or hydraulic power and tag out if required before servicing or performing maintenance.**

1. Disconnect spreader wire harness from chassis harness.
2. Unclip the spreader harness from the hitch and loop the harness around spreader frame.

**NOTE: It is recommended that two people lift the spreader for this removal**

3. Lift Lock bar (A) and slide implement outwards.

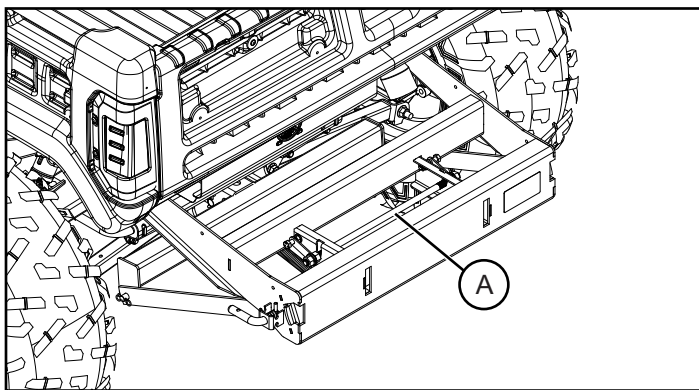

4. Lift away the implement.

## Storage

1. Wash spreader and allow to dry.
2. Apply dielectric grease on all the electrical connections to prevent corrosion.
3. Cover spreader and store.

# Troubleshooting

The Display Module and Control Module work as a system and communicate with each other over the CAN bus. Both modules should be powered up at the same time for proper functionality.

Symptom	Troubleshooting Guide
Control Module and/or Display Module does not turn on  Control Module status light is off  Display Module screen is off and/or status LED is off	<ol style="list-style-type: none"> <li>1. Ensure connections are fully seated.</li> <li>2. Remove front wire harness. Check for 12v at pins A-J at rear connection attachment point.</li> <li>3. If no voltage, vehicle has insufficient power or ground connection. <ul style="list-style-type: none"> <li>• If 12V, check for 12v at pins at pins 2-3 on display side of connector.</li> <li>• If no voltage, replace wire harness.</li> <li>• If 12v, display is faulty. Replace display.</li> </ul> </li> </ol>
No Communications	<p>Check for 12V at Control Module pins M1-M4, if no voltage check:</p> <ul style="list-style-type: none"> <li>• Fuse on Gator Harness</li> <li>• Chassis harness connection</li> <li>• Spreader harness connection.</li> </ul>
No Communications  No CAN communication between Control Module and Display Module	<ul style="list-style-type: none"> <li>• Display harness connection.</li> <li>• Spreader harness connection.</li> <li>• Check continuity from Control Module pin A2 to spreader harness pin 4</li> <li>• Check continuity from Control Module pin C2 to spreader harness pin 5</li> </ul>
Material is not flowing with the gate open	<ul style="list-style-type: none"> <li>• Check that the gate stop is in the correct position according to the calibration procedure and adjust if necessary</li> <li>• Material that has gotten damp may clump and will not flow as well as dry material. Always operate the spreader with the lid installed</li> </ul>

## Display Module Error Codes

SPN	Error	Description	Troubleshooting Guide
1100	High Temperature Fault	Internal temperature above 75C	The module will stop operating the spreader if the internal temperature rises above 75C. This is a latching fault to protect the electronics. Reduce the module's exposure to high temperatures to allow its internal temperature to fall below 75C. The module must be power cycled to recover from a high temperature fault.
1101	High Temperature Warning	Internal temperature above 65C	No action is necessary. The module will continue operating the spreader with an internal temperature between 65C and 75C but will stop operating the spreader if the internal temperature rises above 75C.
1102	Low Temperature Fault	Internal temperature below -30C	The module will stop operating the spreader if the internal temperature falls below -30C. This is a latching fault to protect the electronics. Reduce the module's exposure to low temperatures to allow its internal temperature to rise above -30C. The module must be power cycled to recover from a low temperature fault.

# Troubleshooting

SPN	Error	Description	Troubleshooting Guide
1103	Low Temperature Warning	Internal temperature below -20C	No action is necessary. The module will continue operating the spreader with an internal temperature between -20C and -30C but will stop operating the spreader if the internal temperature falls below -30C.
1104	High Voltage Fault	System voltage above 19V	The module will stop operating the spreader if the system voltage rises above 19V. This is a latching fault to protect the electronics. The module must be power cycled to recover from a high voltage fault. Note that the Display Module high voltage fault is not the same as the Control Module high voltage fault.
1105	High Voltage Warning	System voltage above 18V	No action is necessary. The module will continue operating the spreader with a system voltage between 18V and 19V but will stop operating the spreader if the system voltage rises above 19V. Note that the Display Module high voltage warning is not the same as the Control Module high voltage warning.
1106	Low Voltage Fault	System voltage below 6.5V	The module will stop operating the spreader if the system voltage falls below 6.5V. This is a latching fault to protect the electronics. The module must be power cycled to recover from a low voltage fault. Note that the Display Module low voltage fault is not the same as the Control Module low voltage fault.
1107	Low Voltage Warning	System voltage below 7V	No action is necessary. The module will continue operating the spreader with a system voltage between 7V and 6.5V but will stop operating the spreader if the system voltage falls below 6.5V. Note that the Display Module low voltage warning is not the same as the Control Module low voltage warning.
1108	Lost Communication Fault	Lost CAN communication	The module will stop operating the spreader if the CAN communication with the Motor Control Module is lost. Make sure all wiring harness connections are secure and all wiring is intact and undamaged. The modules must be power cycled to recover from a lost communication fault.
9999	Unknown Fault	Unknown Fault	Contact Superior Tech for support.

## Control Module Error Codes

The Control Module for the Fertilizer Spreader contains two motor drivers: MD1 controls the spinner and MD2 controls the gate actuator. The errors that reference MD1 are related to the spinner. The errors that reference MD2 are related to the gate actuator.

SPN	Error	Description	Troubleshooting Guide
6100	MD1 Open Circuit	Motor Driver 1 output is disconnected	The motor driver checks if a load is connected between the positive and negative motor driver outputs before attempting to drive the motor. This is a latching fault to protect the electronics. Verify that the connections at the Control Module terminals are properly secured, the wiring harnesses are not damaged, and all wiring harness connectors are properly connected. Verify that the motor is not damaged. The module must be power cycled to recover from the open circuit fault.
6101	MD1 Over Current	Motor Driver 1 current draw above 15A	The motor driver will stop operating the spreader if the output current goes above 15A. This is a latching fault to protect the electronics. Verify that the motor is not damaged. A heavily loaded or jammed spinner can result in a very high current draw. Reduce the load on the spinner or clear the jam before power cycling the module to recover from the over current fault.

# Troubleshooting

SPN	Error	Description	Troubleshooting Guide
6102	MD1 Short to Battery	Motor Driver 1 output shorted to battery positive	The motor driver checks if the positive or negative motor driver outputs are shorted to battery positive (12V) before attempting to drive the motor. This is a latching fault to protect the electronics. Verify that the connections at the Control Module terminals are not being bridged by any conductive material. Verify that the wiring harnesses are not damaged and all wiring harness connectors are properly connected.
6103	MD1 Short to Ground	Motor Driver 1 output shorted to battery negative	The motor driver checks if the positive or negative motor driver outputs are shorted to battery negative (ground or 0V) before attempting to drive the motor. This is a latching fault to protect the electronics. Verify that the connections at the Control Module terminals are not being bridged by any conductive material. Verify that the wiring harnesses are not damaged and all wiring harness connectors are properly connected.
6104	MD1 TLE OverTemp Fault	Motor Driver 1 internal temperature above 75C	The module will stop operating the spreader if the internal temperature rises above 75C. This is a latching fault to protect the electronics. Reduce the module's exposure to high temperatures to allow its internal temperature to fall below 75C. The module must be power cycled to recover from a high temperature fault.
6105	MD1 TLE OverTemp Warning	Motor Driver 1 internal temperature above 65C	No action is necessary. The module will continue operating the spreader with an internal temperature between 65C and 75C but will stop operating the spreader if the internal temperature rises above 75C.
6106	MD1 FET Overtemp Fault	Motor Driver 1 FET temperature above 75C	The module will stop operating the spreader if the internal temperature rises above 75C. This is a latching fault to protect the electronics. Reduce the module's exposure to high temperatures to allow its internal temperature to fall below 75C. The module must be power cycled to recover from a high temperature fault.
6107	MD1 FET Overtemp Warning	Motor Driver 1 FET temperature above 65C	No action is necessary. The module will continue operating the spreader with an internal FET temperature between 65C and 75C but will stop operating the spreader if the internal FET temperature rises above 75C.
6108	MD1 High VBAT Fault	Motor Driver 1 voltage above 18V	The module will stop operating the spreader if the system voltage rises above 18V. This is a latching fault to protect the electronics. The module must be power cycled to recover from a high voltage fault. Note that the Control Module high voltage fault is not the same as the Display Module high voltage fault.
6109	MD1 High VBAT Warning	Motor Driver 1 voltage above 16V	No action is necessary. The module will continue operating the spreader with a system voltage between 16V and 18V but will stop operating the spreader if the system voltage rises above 18V. Note that the Control Module high voltage warning is not the same as the Display Module high voltage warning.
6110	MD1 Low VBAT Fault	Motor Driver 1 voltage below 8V	The module will stop operating the spreader if the system voltage falls below 8V. This is a latching fault to protect the electronics. The module must be power cycled to recover from a low voltage fault. Note that the Control Module low voltage fault is not the same as the Display Module low voltage fault.
6111	MD1 Low VBAT Warning	Motor Driver 1 voltage below 9V	No action is necessary. The module will continue operating the spreader with a system voltage between 8V and 9V but will stop operating the spreader if the system voltage falls below 8V. Note that the Control Module low voltage warning is not the same as the Display Module low voltage warning.

# Troubleshooting

SPN	Error	Description	Troubleshooting Guide
6112	MD1 No Communication	Motor Driver 1 is not responding at power up	The module will not operate if it cannot communicate with the internal motor driver at power up. Power cycle the module. If the error is still active contact Superior Tech for support.
6113	MD1 Lost Communication	Motor Driver 1 has lost communication for 10 seconds	The module will stop operating if it loses communication with the internal motor driver for more than 10 seconds. Power cycle the module. If the error is still active contact Superior Tech for support.
6200	MD2 Open Circuit	Motor Driver 2 output is disconnected	The motor driver checks if a load is connected between the positive and negative motor driver outputs before attempting to drive the motor. This is a latching fault to protect the electronics. Verify that the connections at the Control Module terminals are properly secured, the wiring harnesses are not damaged, and all wiring harness connectors are properly connected. Verify that the motor is not damaged. The module must be power cycled to recover from the open circuit fault.
6201	MD2 Over Current	Motor Driver 2 current draw above 15A	The motor driver will stop operating the spreader if the output current goes above 15A. This is a latching fault to protect the electronics. Verify that the motor is not damaged. A heavily loaded or jammed actuator can result in a very high current draw. Reduce the load on the actuator or clear the jam before power cycling the module to recover from the over current fault.
6202	MD2 Short to Battery	Motor Driver 2 output shorted to battery positive	The motor driver checks if the positive or negative motor driver outputs are shorted to battery positive (12V) before attempting to drive the motor. This is a latching fault to protect the electronics. Verify that the connections at the Control Module terminals are not being bridged by any conductive material. Verify that the wiring harnesses are not damaged and all wiring harness connectors are properly connected.
6203	MD2 Short to Ground	Motor Driver 2 output shorted to battery negative	The motor driver checks if the positive or negative motor driver outputs are shorted to battery negative (ground or 0V) before attempting to drive the motor. This is a latching fault to protect the electronics. Verify that the connections at the Control Module terminals are not being bridged by any conductive material. Verify that the wiring harnesses are not damaged and all wiring harness connectors are properly connected.
6204	MD2 TLE OverTemp Fault	Motor Driver 2 internal temperature above 75C	The module will stop operating the spreader if the internal temperature rises above 75C. This is a latching fault to protect the electronics. Reduce the module's exposure to high temperatures to allow its internal temperature to fall below 75C. The module must be power cycled to recover from a high temperature fault.
6205	MD2 TLE OverTemp Warning	Motor Driver 2 internal temperature above 65C	No action is necessary. The module will continue operating the spreader with an internal temperature between 65C and 75C but will stop operating the spreader if the internal temperature rises above 75C.
6206	MD2 FET Overtemp Fault	Motor Driver 2 FET temperature above 75C	The module will stop operating the spreader if the internal temperature rises above 75C. This is a latching fault to protect the electronics. Reduce the module's exposure to high temperatures to allow its internal temperature to fall below 75C. The module must be power cycled to recover from a high temperature fault.
6207	MD2 FET Overtemp Warning	Motor Driver 2 FET temperature above 65C	No action is necessary. The module will continue operating the spreader with an internal FET temperature between 65C and 75C but will stop operating the spreader if the internal FET temperature rises above 75C.

# Troubleshooting

SPN	Error	Description	Troubleshooting Guide
6208	MD2 High VBAT Fault	Motor Driver 2 voltage above 18V	The module will stop operating the spreader if the system voltage rises above 18V. This is a latching fault to protect the electronics. The module must be power cycled to recover from a high voltage fault. Note that the Control Module high voltage fault is not the same as the Display Module high voltage fault.
6209	MD2 High VBAT Warning	Motor Driver 2 voltage above 16V	No action is necessary. The module will continue operating the spreader with a system voltage between 16V and 18V but will stop operating the spreader if the system voltage rises above 18V. Note that the Control Module high voltage warning is not the same as the Display Module high voltage warning.
6210	MD2 Low VBAT Fault	Motor Driver 2 voltage below 8V	The module will stop operating the spreader if the system voltage falls below 8V. This is a latching fault to protect the electronics. The module must be power cycled to recover from a low voltage fault. Note that the Control Module low voltage fault is not the same as the Display Module low voltage fault.
6211	MD2 Low VBAT Warning	Motor Driver 2 voltage below 9V	No action is necessary. The module will continue operating the spreader with a system voltage between 8V and 9V but will stop operating the spreader if the system voltage falls below 8V. Note that the Control Module low voltage warning is not the same as the Display Module low voltage warning.
6212	MD2 No Communication	Motor Driver 2 is not responding at power up	The module will not operate if it cannot communicate with the internal motor driver at power up. Power cycle the module. If the error is still active contact Superior Tech for support.
6213	MD2 Lost Communication	Motor Driver 2 has lost communication for 10 seconds	The module will stop operating if it loses communication with the internal motor driver for more than 10 seconds. Power cycle the module. If the error is still active contact Superior Tech for support.
6400	Motor Driver Mismatch Version	Motor Driver 1 and Motor Driver 2 have different software versions	The module will not operate if the software loaded in the motor drivers does not match. Power cycle the module. If the error is still active contact Superior Tech for support.
6401	Spreader Type Memory Corruption	Spreader Type stored in memory is not valid	The module will not operate if the software does not load the proper spreader type from internal memory. Power cycle the module. If the error is still active contact Superior Tech for support.



# Wiring Diagram

## Spreader Harness Connections

### 2 pin Connector

pin 1	Battery Positive
pin 2	Battery Negative

### 6 pin Connector

pin 1	Switched Battery Positive
pin 2	Battery Negative
pin 3	Ignition
pin 4	CAN-
pin 5	CAN+
pin 6	No Connect

### Control Module Output Terminals

A	Spinner Motor Negative
B	Spinner Motor Positive
C	Battery Negative
D	Battery Positive
E	Gate Actuator Negative
F	Gate Actuator Positive
G	No Connect
H	No Connect



# Specifications

## Spreader

Hopper Volume	Volume 85 L (3 cu ft)
Hopper Capacity	109 kg (240 lb)

## Spinner Motor

Type	12V Brushed DC
Current Draw	5.2 Amps
Speed	Variable, 810 max. RPM
Ratio	8:1
Spread Width	Up to 25 ft (7.6 m)

## Electric Actuator

Type	12V DC Linear
Current Draw	1.5 Amps

## Dimensions

Length	30"
Width	30"
Height	32"

## Weight

Empty	89 lb (20 kg)
-------	---------------

# Good Quality Service

## John Deere Quality Continues with Quality Service

John Deere provides a process to handle your questions or problems, should they arise, to ensure that product quality continues with quality parts and service support.

Follow the steps below to get answers to any questions you may have about your product.

Refer to your attachment and machine operator manuals.

In North America or Canada, call John Deere Special Services at 1-888-867-2238 and provide product serial number (if available) and model number.

# Warranty

## Limited Warranty for New John Deere Licensed Products

Superior Tech spreaders are guaranteed to be free from defects in material and workmanship from the date of purchase for 1 year residential use, 6 months commercial use, provided that the purchaser properly assembles, installs, uses and maintains the products in accordance with this manual.

Purchaser's failure to adhere to such requirements will void the warranty. To the extent permitted by applicable law, all other warranties, representations, obligations and conditions, expressed or implied, including but not limited to implied warranties of merchantability, fitness for any particular purpose and non-infringement, are hereby disclaimed and excluded.

Any product which does not meet warranty shall, as purchaser's sole and exclusive remedy, be repaired or replaced by Superior Tech. This warranty is non-transferable.

In addition, our warranty does not cover:

- Labor charges
- Loss or consequential, incidental or special damages of any kind.

This product was manufactured by Superior Tech, Inc, a John Deere Licensee, located at 1811 Rohrerstown Road, Lancaster, PA 17601. If you have any questions or concerns with the assembly, installation, or operation of this attachment, see your local John Deere dealer or call Superior Tech at 1-888-867-2238 for assistance.

