

# Agri-Fab®

## OWNERS MANUAL

Model No.  
551889A

Includes Deck  
Adapter #62468

**CAUTION:**  
Read Rules for  
Safe Operation  
and Instructions  
Carefully

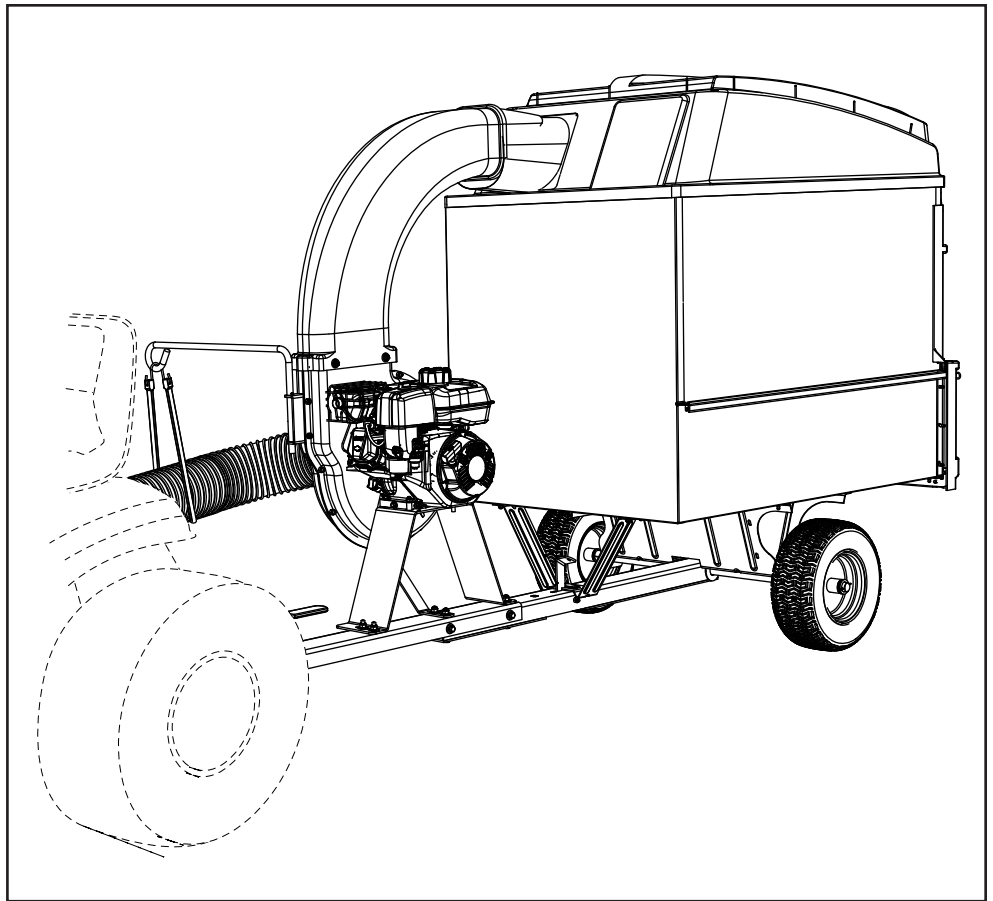

## MOW-N-VAC

**IMPORTANT:** The engine is shipped without oil. Add oil before starting the engine.

**IMPORTANT:** The wheel bearings are not prelubricated. Fill the wheel hubs with grease after assembling the wheels to the axle.

**IMPORTANT:** Check engine air filter prior to each use. Follow the maintenance schedule on page 13 of this manual.

**IMPORTANT:** Hose extension kit #65640 may be required for rear engine tractors and zero turn tractors.



Want more information or assembly tips?  
Scan with free ShowUHow Mobile App  
available at iTunes Store or Android Market.

Or visit [www.agri-fab.com](http://www.agri-fab.com) for product assembly instructions.

Call 1-800-448-9282 for missing parts or assembly help.

**SpeedPart** *the fastest way to purchase parts* [www.speedepart.com](http://www.speedepart.com)

# TABLE OF CONTENTS

SAFETY RULES.....	3,4	STORAGE .....	15
FULL SIZE HARDWARE CHART .....	5,10	TROUBLESHOOTING.....	15
CARTON CONTENTS.....	6	REPAIR PARTS ILLUSTRATIONS .....	17,18,20
ASSEMBLY .....	7	REPAIR PARTS LISTS .....	17,19,20
OPERATION.....	12	SLOPE GUIDE .....	21
MAINTENANCE .....	13	PARTS ORDERING.....	24

## OPTIONAL ACCESSORY MODEL NO. 45-0253 12 FT. REMOTE HOSE KIT

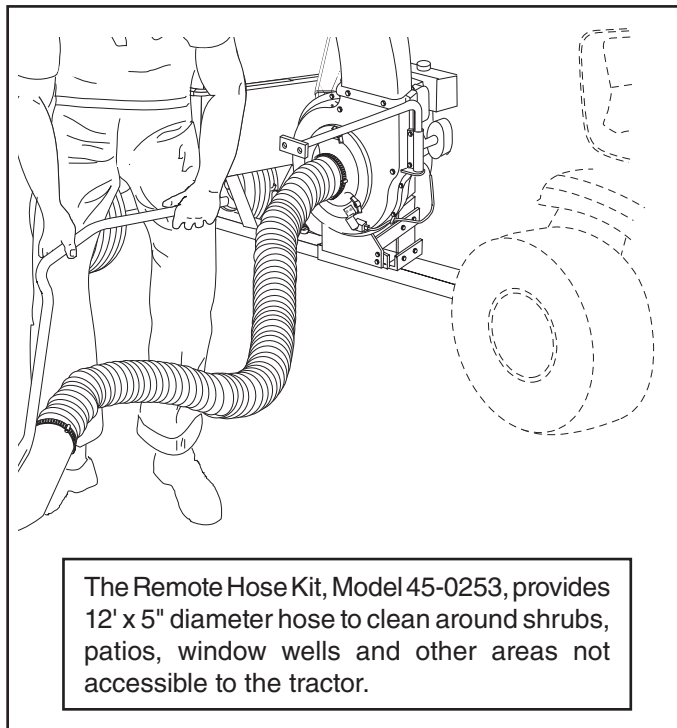

## WARNING

This unit is equipped with an internal combustion engine and should not be used on or near unimproved forest-covered, or grass-covered land unless the engine's exhaust system is equipped with a spark arrester meeting applicable local or state laws (if any). If a spark arrester is used, it should be maintained in effective working order by the operator.

In the State of California the above is required by law (Section 4442 of the California Public Resources Code). Other states may have similar laws. Federal laws apply on federal lands. A spark arrester muffler is available at you nearest engine authorized service center.



## SAFETY



Any power equipment can cause injury if operated improperly or if the user does not understand how to operate the equipment. Exercise caution at all times, when using power equipment.



**DANGER:** This Mow-N-Vac was built to be operated according to the rules for safe operation in this manual. As with any type of power equipment, carelessness or error on the part of the operator can result in serious injury. This unit is capable of amputating fingers and hands and throwing objects. Failure to observe the following safety instructions could result in serious injury or death.

- Read and follow all instructions in this manual before attempting to assemble or operate this equipment. Failure to comply with these instructions may result in personal injury. Keep this manual in a safe place for future reference and for ordering replacement parts.
- Read this operating and service instruction manual carefully. Be thoroughly familiar with the controls and proper use of this power vacuum.
- Read the vehicle owners manual and vehicle safe operation rules before using this equipment.
- Never allow children under 16 to operate this Mow-N-Vac. Children 16 years and older should only operate under close parental supervision.
- Do not allow anyone to operate this equipment without proper instructions.
- Do not allow passengers to ride on this equipment or on the towing vehicle.
- Keep the area of operation clear of all persons, particularly small children. Also keep area clear of pets.
- Check fuel before starting engine. Do not fill fuel tank indoors, or when engine is running, or while engine is hot. Wipe off any spilled fuel before starting engine.
- Engine and muffler get hot. Do not touch! To avoid fire hazard, keep clean of debris and other accumulations.
- Never store Mow-N-Vac with fuel in tank. Allow engine to cool before storing in any enclosure.
- Do not change engine governor settings.
- Do not operate engine if air cleaner or cover is removed, except for adjustment. Removal of these parts could create a fire hazard.
- Keep hands, feet, face, long hair and clothing out of inlet and discharge area. There are ROTATING BLADES inside these openings.
- Before cleaning, repairing or inspecting, make certain all moving parts come to a complete stop. Disconnect spark plug wire and keep wire away from plug to prevent accidental starting. Keep throttle control lever in stop position.
- If the Mow-N-Vac should become blocked with debris at any point, shut engine off and wait until the impeller comes to a complete stop before attempting to remove the obstruction. Disconnect spark plug wire to prevent accidental starting.
- If the cutting mechanism strikes a foreign object, or if your Mow-N-Vac should start to vibrate abnormally, stop the engine immediately, disconnect the spark plug wire and move the wire away from the spark plug. Allow the machine to stop and take the following steps.
  - a. Inspect for damage.
  - b. Repair or replace any damaged parts.
  - c. Check for loose parts and tighten to assure continued safe operation.
- Check all bolts for tightness at frequent intervals to help insure safe operation.
- Check vinyl hard top boot frequently for wear. Replace if worn or damaged.
- Never operate Mow-N-Vac unless deck adapter, hose, hose adapter (nozzle), discharge chute (elbow), and top cover are properly attached in their place.
- Do not remove top cover or attempt to empty contents of cart while engine is running.
- Never attempt to change hose adapter (nozzle) or to install remote hose attachment when engine is running.
- Keep all shields and guards (e.g. discharge chute (elbow) and hose adapter (nozzle) in place and securely attached.
- Always wear safety glasses or other suitable eye protection when operating or maintaining this equipment.
- Do not stand behind cart in exhaust discharge area while engine is running.
- Do not operate this equipment while intoxicated or while taking drugs or medication that impairs the senses and reactions.
- When using this equipment, start with the vehicle transmission in first (low) gear and then gradually increase speed only as conditions permit.
- Operate this equipment at reduced speed on rough terrain, along creeks and ditches and on slopes to prevent tipping or loss of control. Do not drive too close to a creek or ditch.
- Vehicle braking and stability are affected by the addition of this equipment. Do not fill the Mow-N-Vac to its full capacity without checking the capability of the towing vehicle to safely pull and stop with the Mow-N-Vac attached.
- Before operating on any grade (hill) refer to the safety rules in the vehicle owner's manual concerning safe operation on slopes. Also refer to the SLOPE GUIDE on page 23 of this owner's manual. Do not operate on slopes in excess of 10 degrees. **STAY OFF STEEP SLOPES.**
- Follow the maintenance instructions outlined in this manual.



Look for this symbol to point out important safety precautions. It means — **Attention!! Become alert!! Your safety is involved.**

# **WARNING**

## **TO AVOID SERIOUS INJURY**

- Read Owner's Manual and all safety labels on machine before starting and using machine.
- Do Not remove top cover or attempt to empty contents of cart while engine is running.
- Do Not stand behind cart in exhaust discharge area while engine is running.
- Keep hands, feet, face, long hair and clothing out of chipper inlet, vac inlet, and discharge area. There are **ROTATING BLADES** inside these openings.
- Wear approved safety glasses and gloves. Avoid loose fitting clothes.
- Keep the area of operation clear of all persons, particularly small children and pets.
- Keep all shields and guards (e.g. upper chipper chute extension, discharge chute, nozzle assembly) in place and securely attached.
- Check discharge boot frequently for wear. Replace if worn or damaged.
- If unit becomes clogged or jammed, shut off engine right away. Do Not attempt to clear clog or jam with engine running.
- Muffler and engine get hot and can cause burns. Do Not Touch. To avoid a fire hazard, keep leaves, grass and other combustible debris off hot muffler and engine.
- Do Not attempt to remove or attach vac nozzle or optional Hose Kit with engine running.
- Do Not operate unit unless nozzle or optional Hose Kit is secured in place.
- Do Not fill gas tank while engine is running. Allow engine to cool at least 2 minutes before refueling.



## **DANGER**

**HAZARDOUS ROTATING BLADES INSIDE. KEEP HANDS AWAY FROM ALL OPENINGS. DO NOT REMOVE OR ATTACH HOSE, HOSE ADAPTER, ELBOW OR OPTIONAL HOSE KIT WHEN ENGINE IS RUNNING!**



### **WARNING**

**MUFFLER AND  
ADJACENT AREAS  
MAY EXCEED 150 F**

777-5863

## **NOTICE**

**ENGINE WILL NOT RUN  
WITHOUT HOSE ADAPTER INSTALLED  
ON BLOWER HOUSING  
(SEE OWNERS MANUAL)**

## **AVISO**

**EL MOTOR NO FUNCIONARÁ  
SIN INSTALACIÓN DEL ADAPTADOR  
DE LA MANGUERA SOBRE  
LA CUBIERTA DEL SOPLADOR  
(VEA EL MANUAL DE OPERADOR)**

# HARDWARE PACKAGE CONTENTS

## SHOWN FULL SIZE

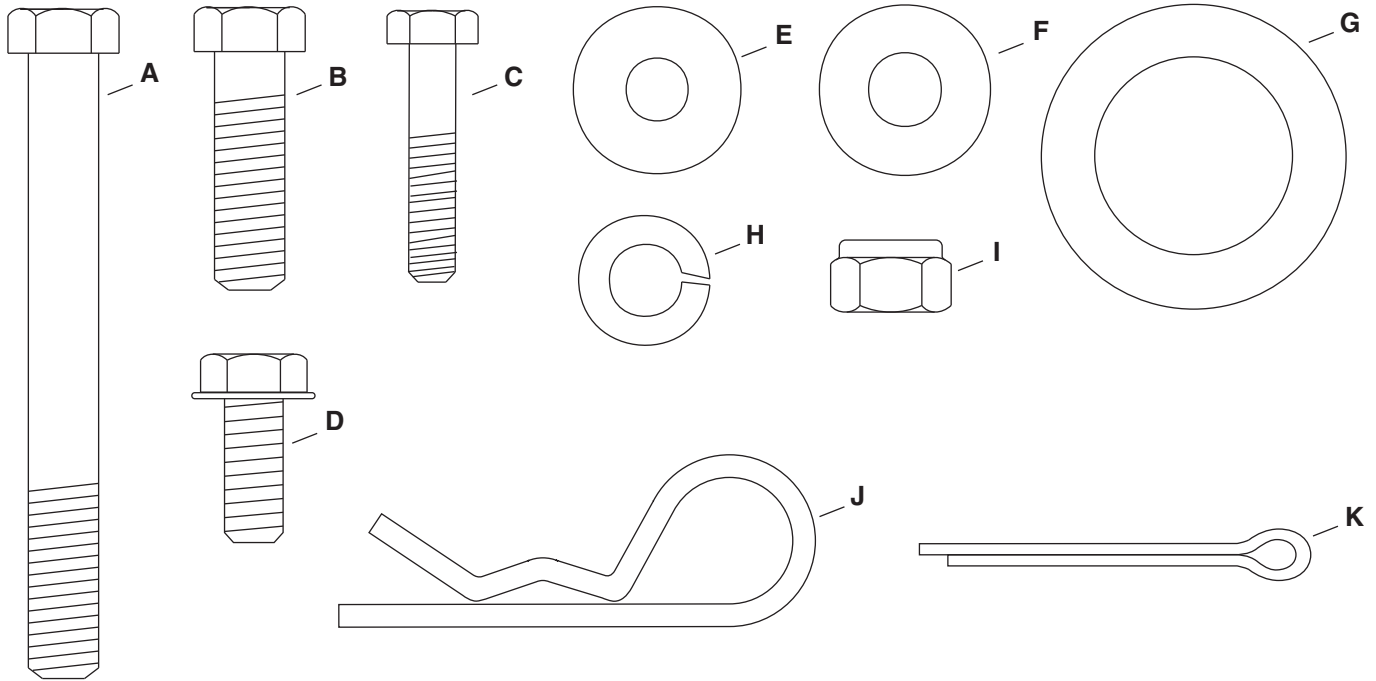

## NOT SHOWN FULL SIZE

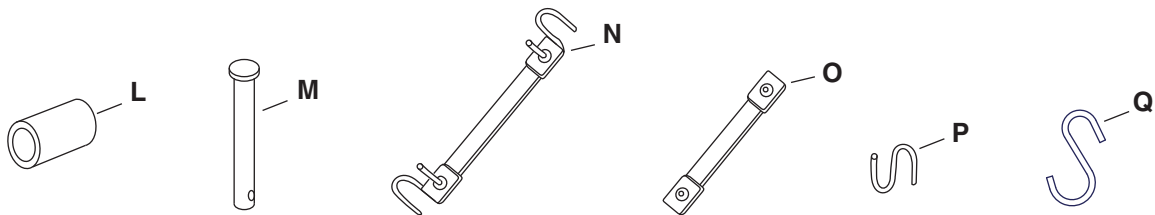

See page 10 for contents of Deck Adapter hardware package. (Contents not included here.)

REF.	PART NO.	QTY	DESCRIPTION	REF.	PART NO.	QTY	DESCRIPTION
A	46938	4	Bolt, Hex 3/8" x 3-1/4"	J	43343	1	Pin, Hair Cotter 1/8"
B	43087	6	Bolt, Hex 3/8" x 1-1/4"	K	43093	2	Pin, Cotter 1/8" x 1-1/2"
C	1509-90	3	Bolt, Hex 1/4" x 1-1/4"	L	44678	2	Spacer Tube
D	47630	4	Bolt, Hex 5/16" x 3/4" (ST)	M	49932	1	Hitch Pin
E	1543-69	4	Washer, Nylon	N	43790	1	Tarp Strap, 25"
F	43081	16	Washer, Flat 5/16"	O	44850	2	Tarp Strap (Less Hooks)
G	43601	4	Washer, Flat 1"	P	44849	2	"S" Hooks
H	43003	4	Lock Washer, 3/8"	Q	42749	1	S" Hook (Large)
I	HA21362	6	Nylock Hex Nut, 3/8"				

# CARTON CONTENTS

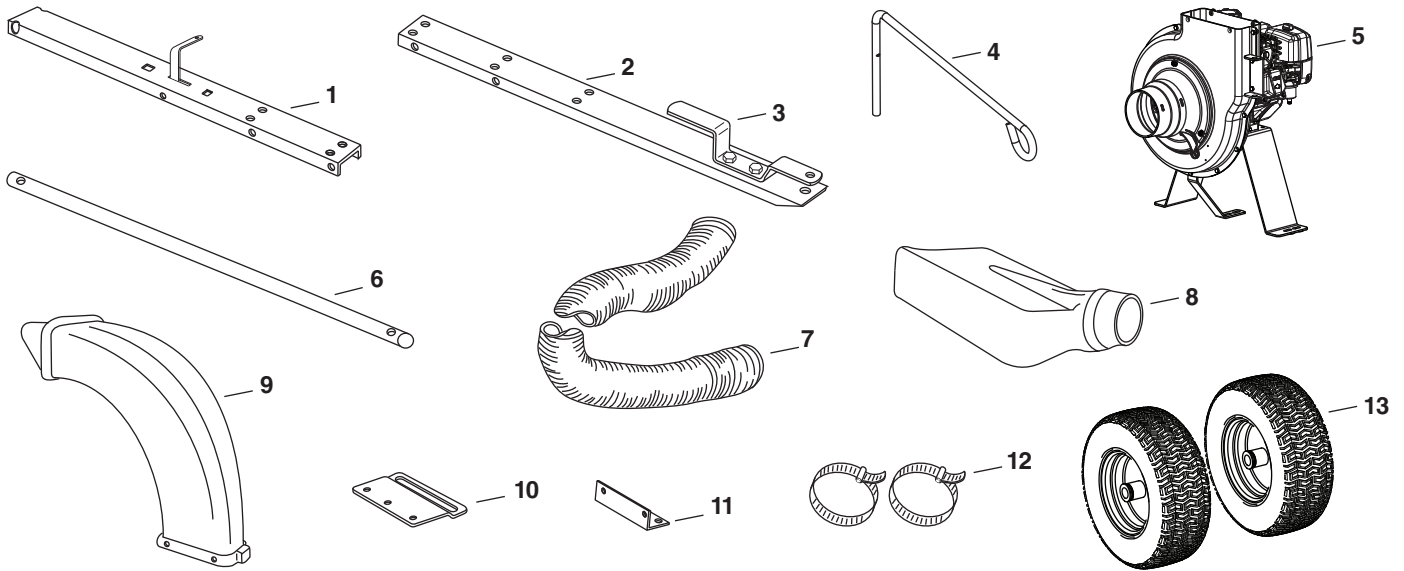

## CARTON CONTENTS

REF.	PART NO.	QTY.	DESCRIPTION	REF.	PART NO.	QTY.	DESCRIPTION
1	----	1	Rear Tongue w/Latch	8	43830	1	Deck Adapter
2	27863	1	Front Tongue	9	46420	1	Elbow
3	27264	1	Hitch Bracket	10	23560	1	Adapter Bracket
4	49974	1	Hose Hanger Rod	11	27304	1	Attachment Bracket
5	----	1	Engine Base Assembly	12	43793	2	Hose Clamp
6	24897	1	Axle	13	42159	2	Wheels
7	41882	1	Hose				

# ASSEMBLY

This unit is shipped WITHOUT GASOLINE or OIL. After assembly, see separate engine manual for proper fuel and engine oil recommendations.

## TOOLS REQUIRED FOR ASSEMBLY

- 1) 1/2" Wrench
- (2) 9/16" Wrenches
- (1) Pliers

## REMOVAL OF PARTS FROM CARTONS

1. Remove the hardware packs and all loose parts from the cartons.
2. Lay out and identify parts shown in carton contents.
3. Lay out and identify parts in the hardware packs. Keep contents of each hardware package separate.

## ASSEMBLING THE MOW-N-VAC

1. Tip the cart back to rest upright on the rear of the cart. See figure 1.
2. Install the rear tongue and the axle onto the cart body, sliding the axle through the wheel support and the tongue. Lock the tongue to the latch stand bracket with the latch lock lever. See figure 1.

**IMPORTANT:** Make sure the tongue is securely locked to the latch stand bracket by the latch lock lever.

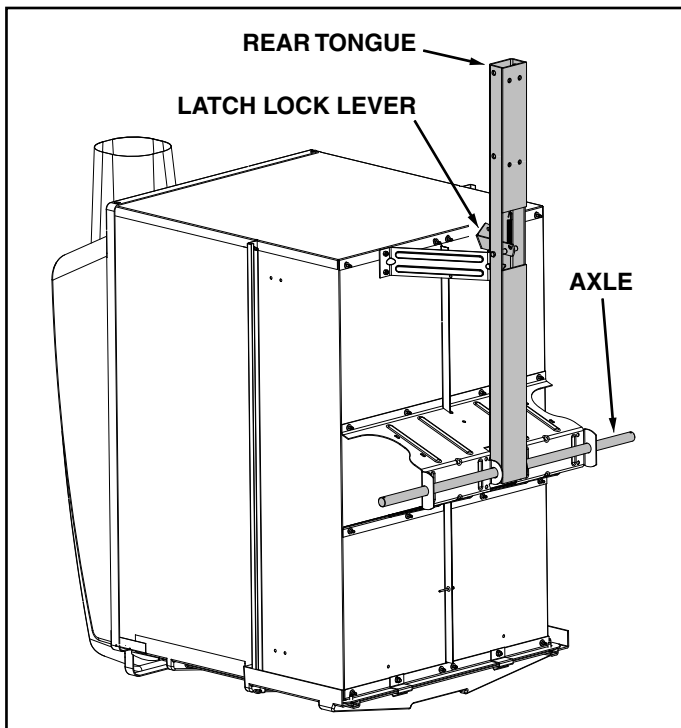

FIGURE 1

3. Assemble a spacer tube, a 1" flat washer, a wheel (valve stem facing out), and another 1" flat washer onto the axle as shown in figure 2. Secure the wheel with a cotter pin, spreading the ends of the pin. Repeat on other end of axle.
4. Pump grease into grease fittings on wheels until grease is forced out through ends of hubs.

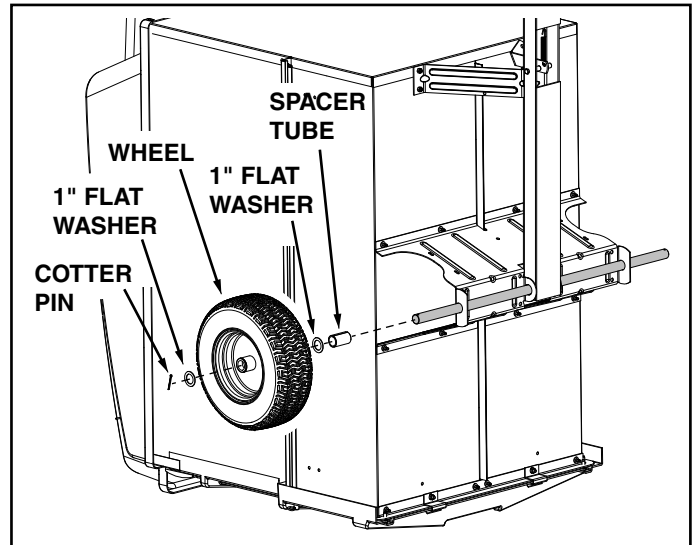

FIGURE 2

5. Tip the cart forward so that it rests on its wheels.
6. Assemble the front tongue on top of the rear tongue using four 3/8" x 1-1/4" hex bolts, 3/8" lock washers and 5/16" flat washers. See figure 3.  
**HINT:** For easier assembly, support the rear tongue with a block of wood.

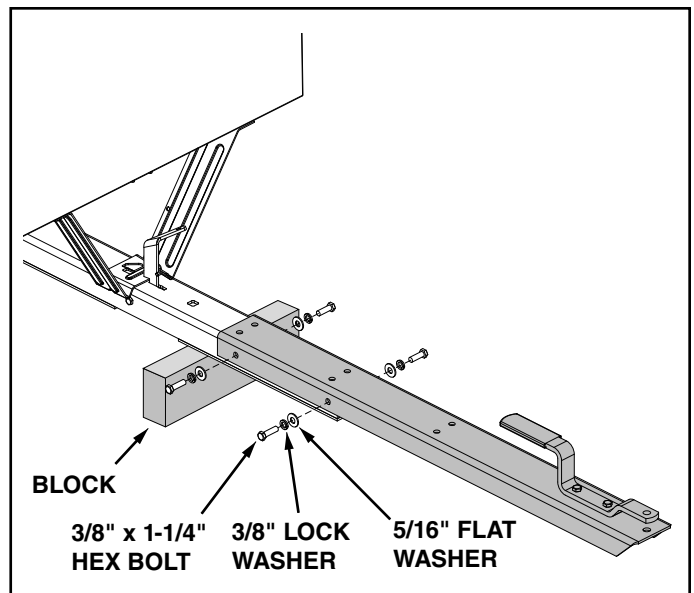

FIGURE 3

7. Secure the hitch pin to the hitch bracket and tongue with the hair cotter pin. See figure 4.

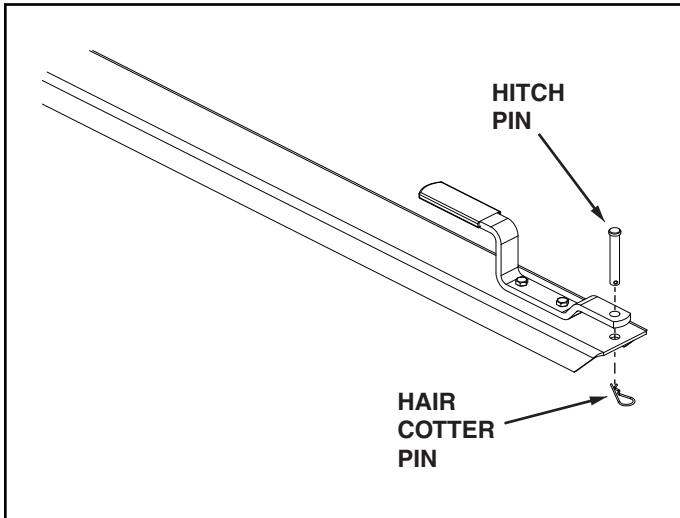

FIGURE 4

8. Attach the engine base assembly to the tongue using four 3/8" x 3-1/4" hex bolts, two 3/8" x 1-1/4" hex bolts, twelve 5/16" flat washers and six 3/8" nylock nuts. **Tighten.** See figure 5.

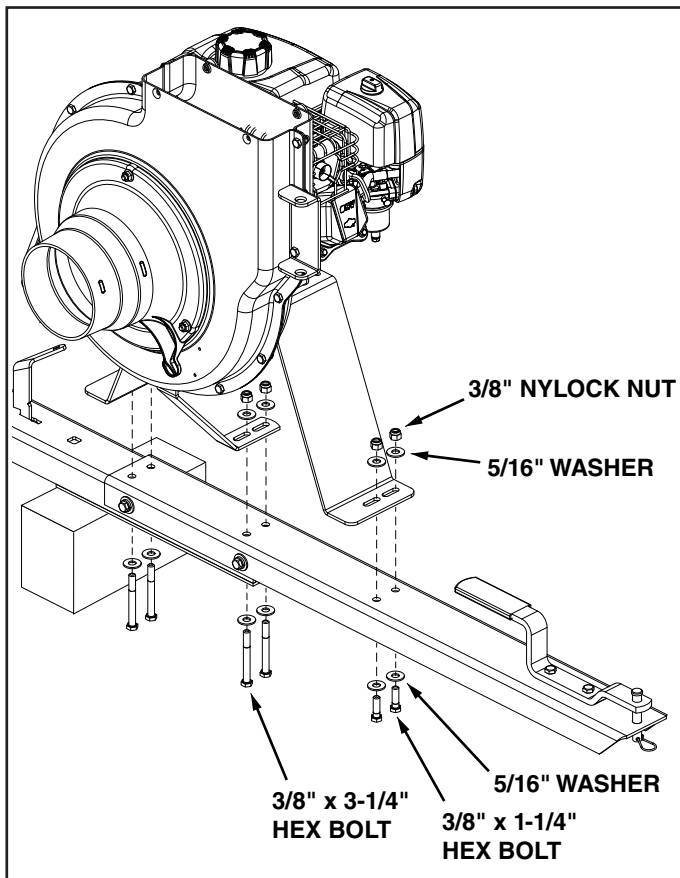

FIGURE 5

9. Assemble the elbow to the impeller housing using four 5/16" x 3/4" self tapping hex bolts and four nylon washers. Push while turning to help start the bolts into the unthreaded holes. **Tighten.** See figure 6

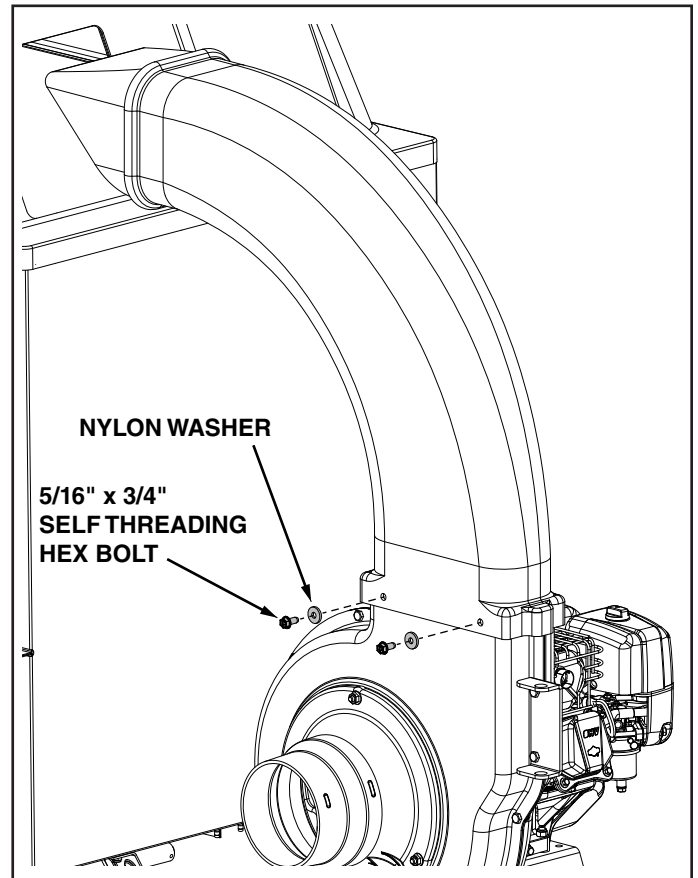

FIGURE 6



10. To align the elbow with the opening in the hard top:
  - a. Push the vinyl boot back inside the opening.
  - b. Loosen by approximately 1/2 turn each, the six bolts that you assembled that fasten the engine base to the tongue.
  - c. Slide the engine base assembly sideways until the elbow is aligned with the opening in the hardtop.
  - d. **Retighten** the six bolts that you loosened.
11. Pull the vinyl boot onto the end of the elbow.

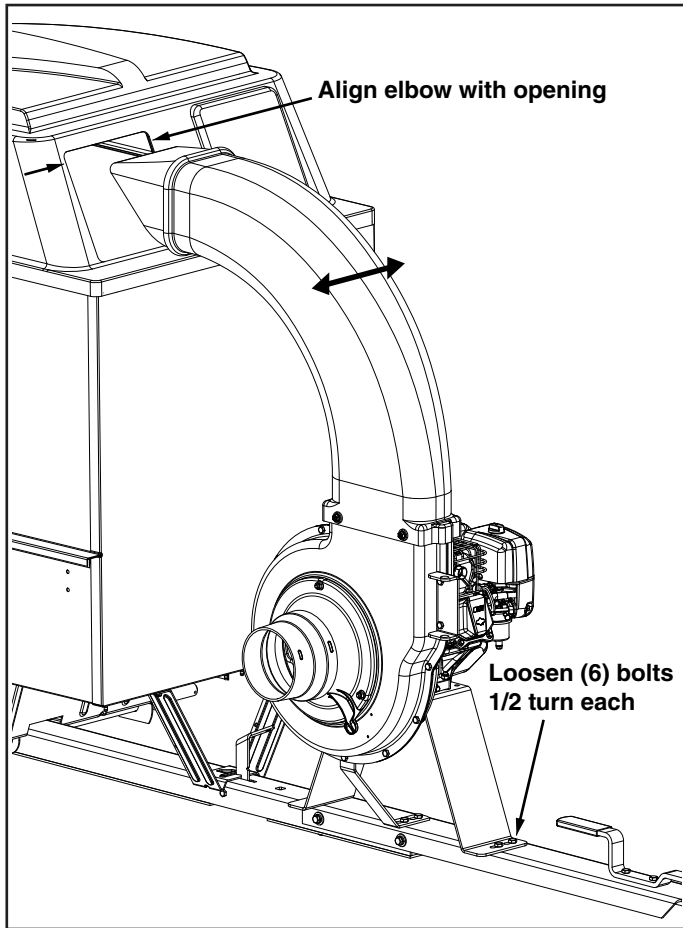

FIGURE 7

12. Place a hose clamp onto the end of the hose. Push the hose onto the hose adapter (nozzle). Tighten the hose clamp onto the hose and hose adapter. **Do not collapse hose adapter when tightening clamp.** See figure 8.
13. The remaining hose clamp will later be used to fasten the other end of the hose to the deck adapter.

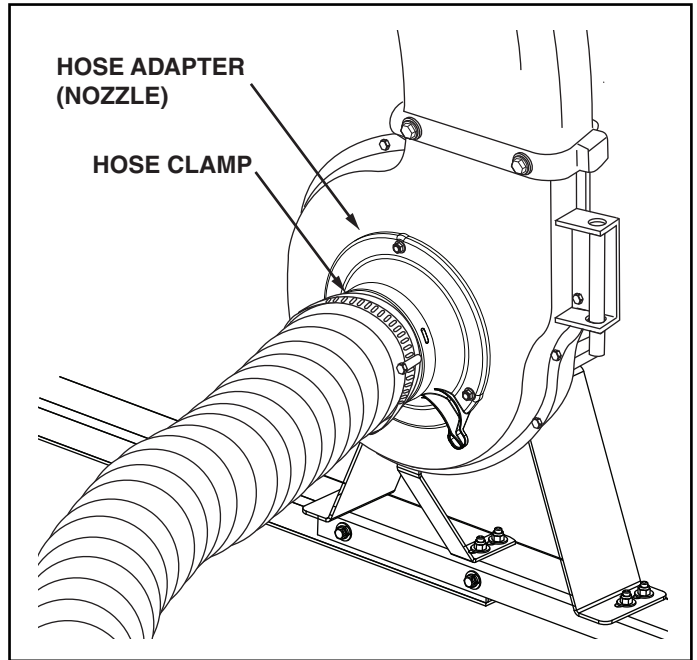

FIGURE 8

14. Place the hose hanger rod into the hose hanger bracket on the impeller housing assembly. See figure 9.
15. Loop the 25" tarp strap under the hose. Fasten the hooks to the hose hanger rod. See figure 9.

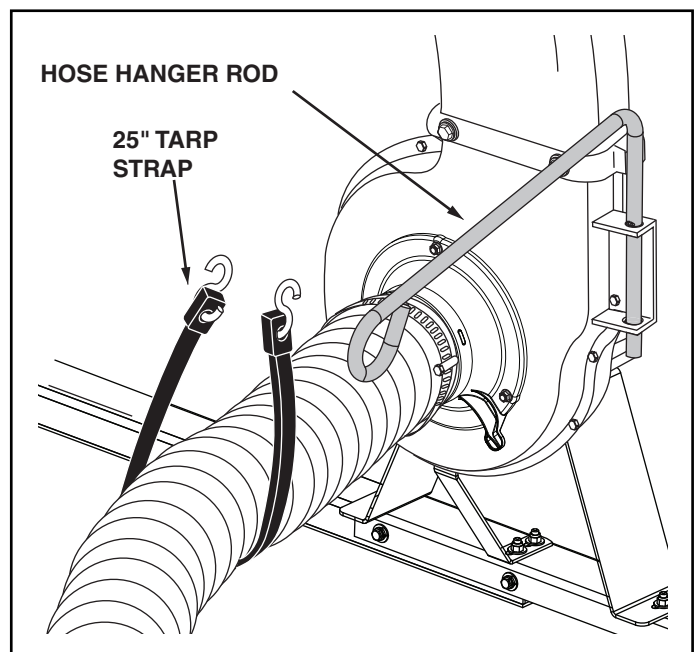

FIGURE 9



**BEFORE PROCEEDING**, look in the fold-out sheets to find the template for your mower deck. If written instructions are printed on the template, follow those instructions instead of the instructions in this manual.

## ASSEMBLING THE DECK ADAPTER (#62468) TO THE MOWER DECK

Need more help cutting out and assembling the deck adapter? Scan the QR Code below with free ShowUHow Mobile App available at iTunes Store or Android Market and refer to Segment 6.

Or visit [www.agri-fab.com](http://www.agri-fab.com) for product assembly instructions.



### Contents of Hardware Pack for Deck Adapter:

REF.	PART NO.	QTY.	DESCRIPTION
A	43840	2	Hex Bolt, 5/16" x 1-1/4"
B	43661	4	Hex Bolt, 1/4" x 1"
C	43080	2	Carriage Bolt, 5/16" x 3/4"
D	47810	3	Hex Nylock Nut, 5/16"
E	47189	5	Hex Nylock Nut, 1/4"
F	43088	9	Flat Steel Washer, 1/4" Std.
G	43081	12	Flat Washer, 5/16" Std.
H	1543-69	5	Nylon Washer
I	23825	1	Mounting Strap
J	23826	1	Angle Bracket
K	23827	1	Mounting Bracket

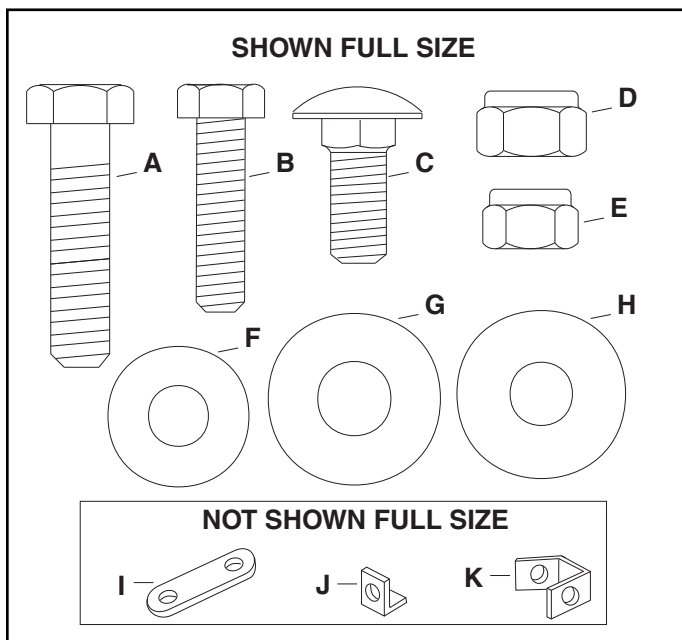

FIGURE 10

**NOTE:** Not all of the hardware will be used for any one particular fit up.

1. Identify and cut out the template for your **brand and size** mower deck. If there is no template included for your deck size, you can make your own template by marking around a piece of cardboard held against the edge of the deck's discharge opening.
2. **FOLLOW THE INSTRUCTIONS PRINTED ON THE TEMPLATE.** If there are no instructions, use the following instructions as a general guide.
3. Tape the template to the face of the adapter, about 1/2" from front and 1/4" down from top for deeper decks. For shallow decks, position template low enough that adapter will not extend below bottom of deck. Mark outline of template on face of adapter using white crayon, nail or scribe. Drill a starting hole inside the outline, then use a saber saw or key hole saw to cut out the opening. See figure 11.

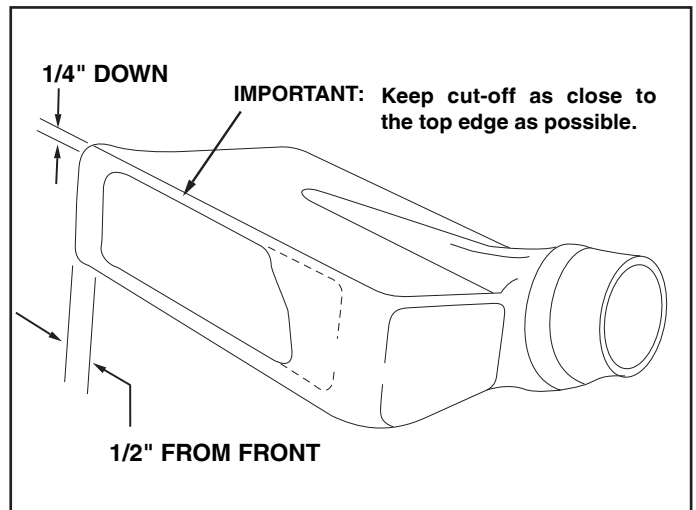

FIGURE 11

### PERFORM THIS STEP ONLY IF NECESSARY.

4. Remove the mower discharge deflector from your mower deck if necessary to attach deck adapter. Save the deflector and hardware for remounting deflector.



**CAUTION:** Mower deflector must be replaced when Vac System deck adapter is removed. Do Not operate mower unless adapter or deflector is in place and properly mounted.

- Position the adapter over the deck opening, and check for fit of cutout as shown in figure 12. Trim cutout, if necessary, to allow tilting of adapter, keeping the fit as close as possible for best vacuum suction.

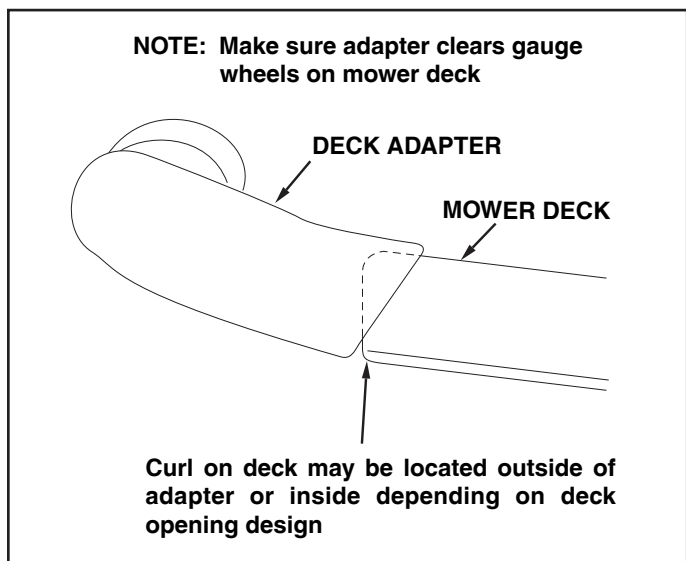

FIGURE 12

- Holding the adapter bracket and the deck adapter together, position the deck adapter on the mower deck. Keeping the edge of deck adapter as close as possible to the offset in the adapter bracket, see if the slot in the adapter bracket can be aligned with one or two of the deflector holes in your mower deck's discharge opening. If the bracket can not be located correctly using existing holes, it will be necessary to drill one or two 5/16" diameter holes in the deck. See figure 13.

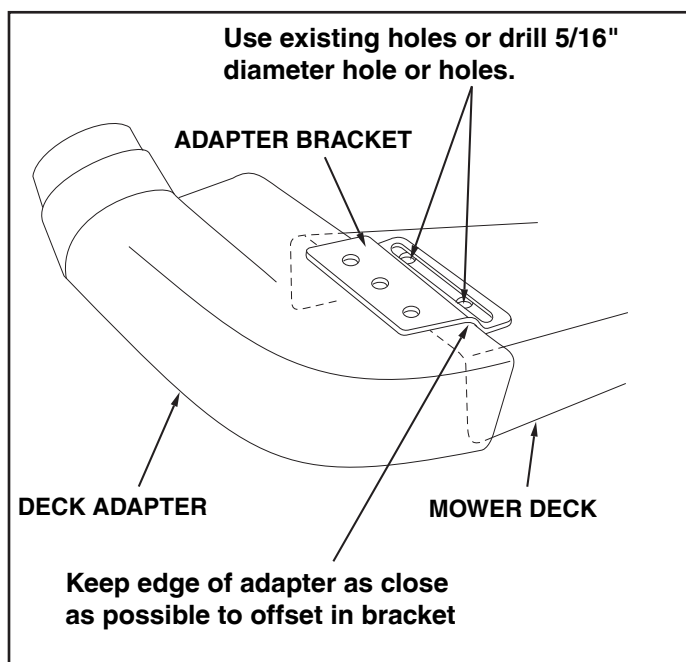

FIGURE 13

- Assemble the adapter bracket to the deck using two 5/16" x 1" hex bolts, 5/16" flat washers and 5/16" Nylock hex nuts. See figure 14.

**NOTE:** It may be necessary to use extra 5/16" flat washers to shim under the bracket next to the deck surface. Ten extra washers have been furnished as shims. See figure 14.

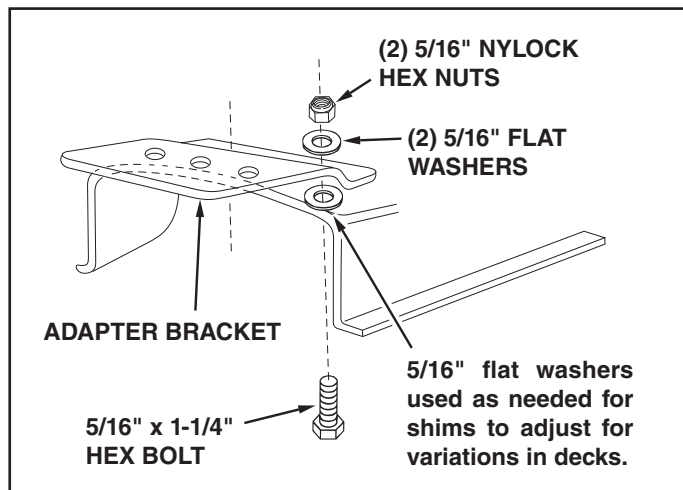

FIGURE 14

- With deck adapter positioned correctly over the discharge opening, use the adapter bracket as a template and drill three 9/32" diameter holes in the top of the deck adapter. See figure 15.
- Bolt deck adapter to bracket using three 1/4" x 1" bolts, nylon washers, 1/4" flat washers and 1/4" Nylock hex nuts. Nylon washers should be against the inside of the deck adapter. See figure 15.

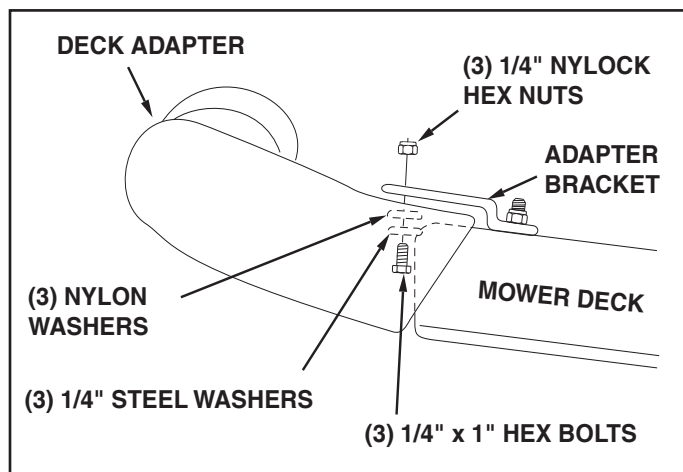

FIGURE 15

- Assemble end of hose and a hose clamp over the round opening of deck adapter and tighten clamp. **GO DIRECTLY TO THE OPERATION INSTRUCTIONS ON PAGE 12.**

# OPERATION

## BEFORE STARTING

1. Your Chip-N-Vac engine is shipped without oil or gasoline. Service the Chip-N-Vac engine with oil and gas as instructed in the separate engine manual.
2. Inspect the Chip-N-Vac to make sure all covers (rear door, vinyl boot, elbow, hose adapter, hose and deck adapter are properly attached.
3. Check tires for proper inflation (12 - 14 lbs). **Do not exceed** the maximum pressure printed on the side of the tires.



**WARNING:** Never fill fuel tank indoors, or with the engine running, or while the engine is hot. Do not smoke while filling tank.

## HOW TO STOP YOUR CHIP-N-VAC

1. To stop engine, move the throttle control lever to the OFF position.
2. Disconnect spark plug wire from plug to prevent accidental starting while equipment is unattended or is being worked on.



**CAUTION:** The muffler and adjacent areas are **hot!**

## HOW TO START YOUR CHIP-N-VAC



**WARNING:** Never start or run the engine without all covers being properly attached to the blower housing and cart.

1. Check oil and gas in Chip-N-Vac engine.
2. Attach spark plug wire to spark plug.
3. Move choke lever on engine to CHOKE position. (A warm engine may not require choking.)
4. Move throttle control lever on engine to FAST position.
5. Grasp starter handle and pull rope out slowly until engine reaches start of compression cycle (rope will pull slightly harder at this point). Let the rope rewind slowly.
6. Pull rope with a rapid, continuous, full arm stroke. Keep a firm grip on starter handle. Let rope rewind slowly. Do not let starter handle snap back against starter.
7. Repeat instructions in two preceding paragraphs until engine fires. When engine starts, move choke control gradually to RUN position.

## HOW TO USE YOUR CHIP-N-VAC



**CAUTION:** Vehicle braking and stability may be affected with the addition of an accessory or an attachment. Be aware of changing conditions on slopes.

1. Begin operation at low speed, adjusting forward speed to match grass height and/or moisture condition to prevent clogging.
2. Do not attempt to vacuum up any material other than vegetation found in a normal yard, such as light branches, leaves, twigs, etc.



**WARNING:** Should your Chip-N-Vac become clogged, shut off tractor and Chip-N-Vac engines. Before attempting to unclog, remove wire from spark plug to prevent accidental starting.

3. To empty cart, shut off tractor engine and set brake.
4. Shut off Chip-N-Vac engine.
5. Remove rear door from cart.
6. Release the latch holding cart down to the tongue by pulling up on the latch lever. See figure 16.
7. Using a rake or suitable tool, pull the grass clippings and/or leaves out of cart.



**CAUTION:** To avoid possible injury, be sure that no one is near the cart before releasing the latch.

8. After cart is emptied, secure cart to tongue with latch and reattach the rear door and the vinyl boot.

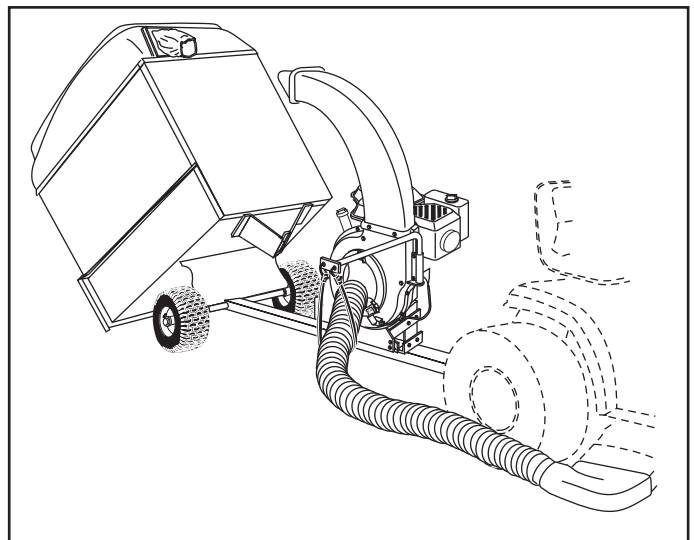

**FIGURE 16**

# MAINTENANCE

## CUSTOMER RESPONSIBILITIES

- Read and follow the maintenance schedule and the maintenance procedures listed in this section.

MAINTENANCE SCHEDULE Fill in dates as you complete regular service.								Service Dates				
	Before each use	After each use	Before storage	First 5 to 8 hrs.	25 hrs. or every season	50 hrs. or every season	100 hrs. or every season					
Check engine oil level	X											
Check tire pressure	X											
Check soft vinyl boot	X											
Check for loose fasteners	X											
Clean		X	X									
Change engine oil				X		X*						
Check air filter pre-cleaner	X											
Check air filter cartridge	X											
Service air filter pre-cleaner					X**							
Service air filter cartridge					X**							
Replace spark plug							X					
Lubricate					X							
Maintain engine per instructions below and in engine manual.												

\*Change oil every 25 hours when operating the engine under heavy load or in high temperatures.

\*\*Clean more often under dusty conditions or when airborne debris is present. Replace air cleaner parts, if very dirty.

## BEFORE EACH USE

### CHECK FOR LOOSE FASTENERS

- Make a thorough visual check of the Mow-N- Vac for any bolts and nuts which may have loosened. Retighten any loose bolts and nuts.

### CHECK VINYL BOOT

- Check the soft vinyl boot (on front of hard top) for wear. Replace if worn or damaged.

### CHECK TIRE PRESSURE

- Check tire pressure regularly. Recommended tire pressure is 12-14 Lbs. Do not exceed the maximum pressure listed on the side of the tires.

### CHECK ENGINE OIL LEVEL

- Check oil level before each use. Maintain engine oil as instructed in the separate engine manual.

### CHECK AIR FILTER

- Check air filter before each use. Clean if dirt is present. Refer to instructions on page 14.

## LUBRICATION

- At the beginning of each season, lubricate the latch, latch pivot bolt, and the axle where the hitch tongue pivots, with a light machine oil.
- At least once a season, grease or oil the wheel bearings. Use automotive wheel bearing type grease or 20 weight oil.



**WARNING:** Always stop engine and disconnect spark plug wire before cleaning, lubricating or before performing any repairs or maintenance.

## ENGINE MAINTENANCE

- Check **oil level** before each use. Maintain engine oil as instructed in the separate engine manual.
- Service **air cleaner** every 25 hours under normal conditions. Clean every few hours under extremely dusty conditions. Poor engine performance and flooding usually indicates that the air cleaner should be serviced. To service the air cleaner, refer to page 14 or the separate engine manual.
- The **spark plug** should be cleaned and the gap reset once a season. Spark plug replacement is recommended at the start of each season. Check the engine manual for correct plug type and gap specifications.

## CLEANING

- Make sure the cart, the side and front panels and top are cleaned after each use. Grass clippings and leaves left in the cart will mildew and cause damage if not cleaned out.
- Clean the engine** regularly with a cloth or brush. Keep the cooling fins on the engine housing clean to permit proper air circulation which is essential to engine performance and life. Be sure to remove all dirt and debris from muffler area.

## SERVICE AIR FILTER



**WARNING:** Fuel and its vapors are extremely flammable and explosive. Fire or explosion can cause severe burns or death.

- Never start and run the engine with the air cleaner assembly or the air filter removed.
- Remove the cover **B** as shown in figure 17.
- To prevent debris from falling into the carburetor, carefully remove the pre-cleaner **D** and filter **C** from the air filter base **F**. See figure 17.
- Gently tap the filter **C** on a hard surface to loosen debris. If the filter is excessively dirty, replace with a new filter. See figure 17.
- Remove the pre-cleaner **D** from the filter **C**. See figure 17.
- Wash the pre-cleaner **D** in liquid detergent and water. Allow the pre-cleaner to thoroughly air dry. Do not oil the pre-cleaner.
- Assemble the dry pre-cleaner **D** to the filter **C**.
- Install the filter **C** and pre-cleaner **D** to air filter base **F** and onto stud **G**. Make sure filter is properly assembled to air filter base and secure with fastener **E**. See figure 17.
- Install the cover **B** and secure with fastener **A**. Make sure fastener is tight. See figure 17.

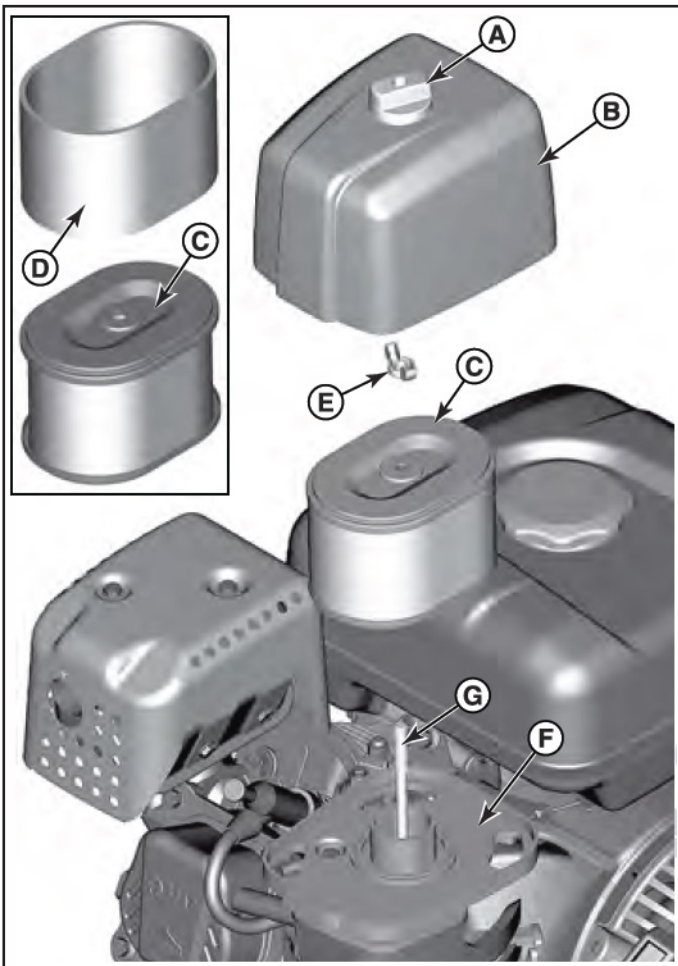

FIGURE 17

## REMOVING THE IMPELLER



**WARNING:** Always stop the engine and remove the spark plug wire before working on the engine or the impeller housing assembly.

1. Remove the outer impeller housing assembly.
2. Remove the bolt from the impeller hub. See figure 18.
3. Screw three 3/8" x 2" full thread bolts into the three nuts welded to the impeller until they contact the housing behind the impeller. See figure 18.
4. Continue screwing in the bolts about 1/2 turn at a time in sequence until the impeller breaks free from the engine drive shaft.

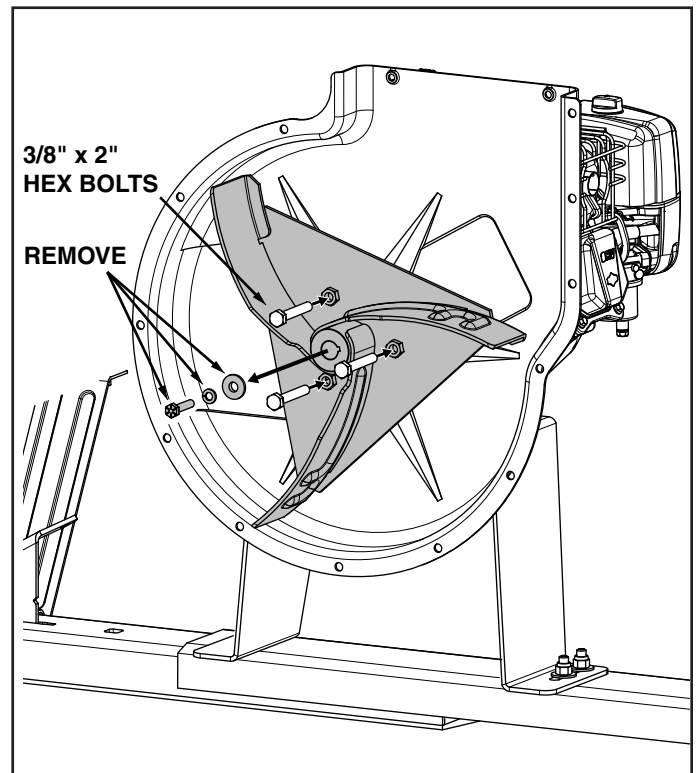

FIGURE 18

## STORAGE

1. Clean the engine and the entire unit thoroughly.
2. Refer to engine manual for correct engine storage instructions.
3. If storing in an unventilated or metal storage shed, coat metal parts with light oil or silicone to prevent rust.
4. Store unit in a clean, dry area.

## TROUBLESHOOTING

PROBLEM	POSSIBLE CAUSE(S)	CORRECTIVE ACTION
Engine fails to start	<ol style="list-style-type: none"> <li>1. Spark plug wire disconnected.</li> <li>2. Fuel tank empty, or stale fuel.</li> <li>3. Fuel shut-off valve closed (if so equipped).</li> <li>4. Faulty spark plug.</li> </ol>	<ol style="list-style-type: none"> <li>1. Connect wire to spark plug.</li> <li>2. Fill tank with clean, fresh fuel.</li> <li>3. Open fuel shut-off valve.</li> <li>4. Clean, adjust gap or replace.</li> </ol>
Loss of power; operation erratic.	<ol style="list-style-type: none"> <li>1. Spark plug wire loose</li> <li>2. Unit running on CHOKE.</li> <li>3. Blocked fuel line or stale fuel.</li> <li>4. Water or dirt in fuel system.</li> <li>5. Carburetor out of adjustment.</li> <li>6. Dirty air cleaner.</li> </ol>	<ol style="list-style-type: none"> <li>1. Connect and tighten spark plug wire.</li> <li>2. Move choke lever to OFF position.</li> <li>3. Clean fuel line; fill tank with clean fresh gasoline.</li> <li>4. Disconnect fuel line at carburetor to drain fuel tank. Refill with fresh fuel.</li> <li>5. Adjust carburetor.*</li> <li>6. Service air cleaner.*</li> </ol>
Engine overheats	<ol style="list-style-type: none"> <li>1. Carburetor not adjusted properly.</li> <li>2. Engine oil level low.</li> </ol>	<ol style="list-style-type: none"> <li>1. Adjust carburetor.*</li> <li>2. Fill crankcase with proper oil.</li> </ol>
Too much vibration	Loose parts or damaged impeller.	Stop engine immediately and disconnect spark plug wire. Tighten all bolts and nuts. Make all necessary repairs. If vibration continues, have unit serviced by an authorized service dealer.
Unit does not discharge	<ol style="list-style-type: none"> <li>1. Discharge chute (elbow) clogged.</li> <li>2. Foreign object lodged in impeller.</li> <li>3. Mow-N-Vac cart is full.</li> </ol>	<ol style="list-style-type: none"> <li>1. Stop engine immediately and disconnect spark plug wire. Clean inside of housing and discharge chute (elbow).</li> <li>2. Stop engine immediately and disconnect spark plug wire. Remove lodged object.</li> <li>3. Empty cart.</li> </ol>

\*Refer to the engine manual packed with your unit.

**NOTE:** For repairs beyond the minor adjustments listed above, please contact your nearest authorized service dealer.





# PARTS

## REPAIR PARTS FOR MOW-N-VAC CART BODY MODEL 551889A

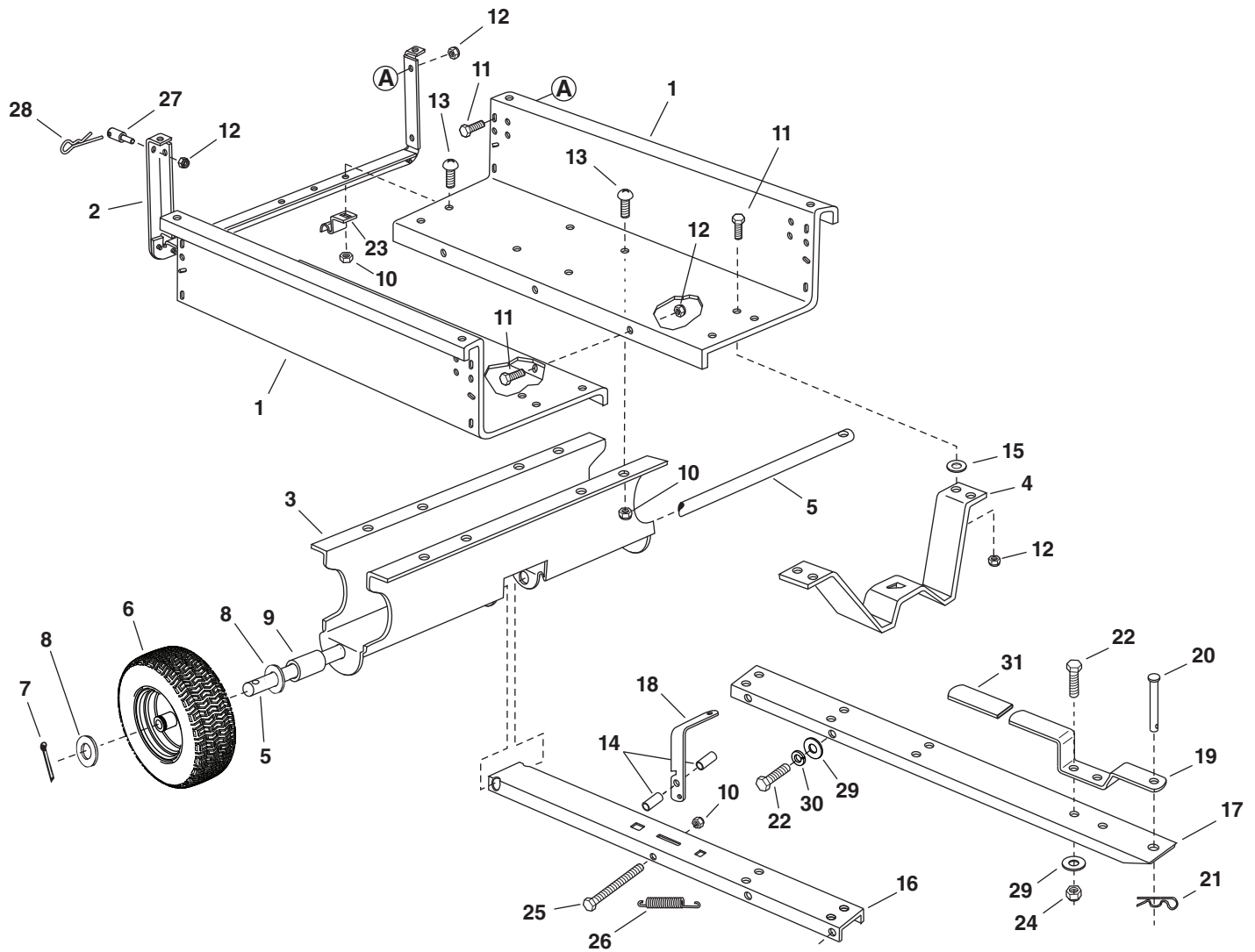

REF.	PART NO.	QTY.	DESCRIPTION	REF.	PART NO.	QTY.	DESCRIPTION
1	23985	2	Cart Body	17	27863	1	Tongue (Front)
2	62458	1	Tailgate Reinforcement Bracket	18	24614	1	Latch Lock Lever
3	23507	1	Wheel Support	19	27264	1	Hitch Bracket
4	24497	1	Latch Stand Bracket	20	49932	1	Hitch Pin
5	24897	1	Axle, Wheel 1" Dia.	21	43343	1	Pin, Hair Cotter 1/8"
6	42159	2	Wheel w/Tire, 15 x 6.00	22	43087	6	Hex Bolt, 3/8-16 x 1-1/4"
7	43093	2	Cotter Pin, 1/8" Dia. x 1-1/2"	23	23838	2	Door Support
8	43601	4	Washer, Flat 1"	24	HA21362	2	Nut, Hex Nylock 3/8-16
9	44678	2	Spacer Tube, 1-1/4" x 2" Lg.	25	47407	1	Hex Bolt, 5/16-18 x 3-3/4"
10	47810	13	Hex Nut, 5/16-18 Nylock	26	47408	1	Spring, Extension
11	43866	9	Hex Bolt, 1/4-20 x 5/8"	27	42999	2	Pin
12	47189	9	Hex Nut, 1/4-20 Nylock	28	48934	2	Hairpin
13	43814	12	Truss Hd. Bolt, 5/16-18 x 3/4"	29	43081	6	Washer, 5/16"
14	41076	2	Spacer	30	43003	4	Lock Washer, 3/8"
15	43088	2	Washer, Flat 1/4"	31	47707	1	Grip
16	68346	1	Tongue Weldment Ass'y. (Rear)				

# REPAIR PARTS FOR MOW-N-VAC MODEL 551889A

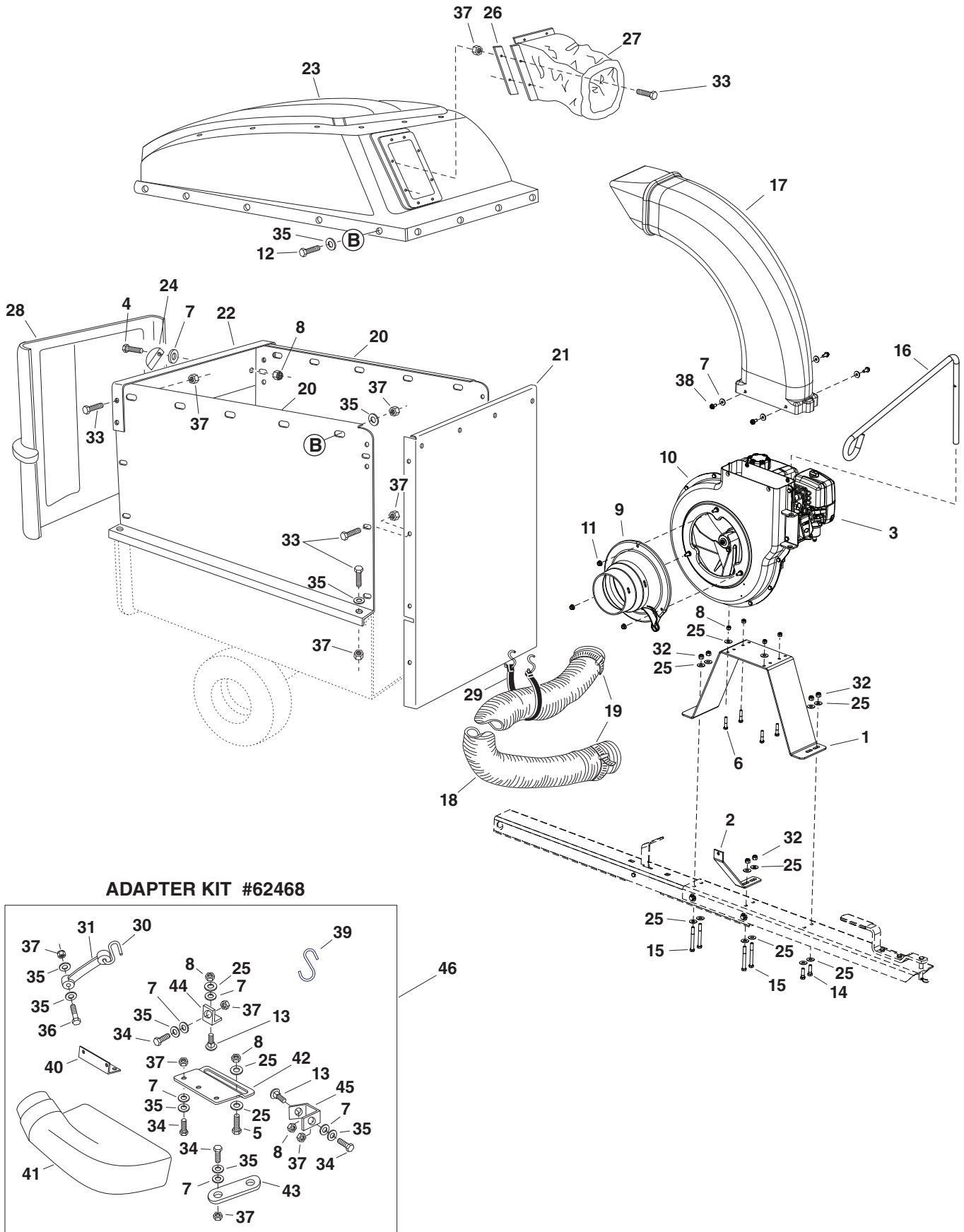

**REPAIR PARTS FOR MOW-N-VAC  
MODEL 551889A**

REF	PART NO.	QTY.	DESCRIPTION	REF	PART NO.	QTY.	DESCRIPTION
1	27883	1	Engine Base	24	23789	2	Door Latch
2	27882	2	Brace, Housing	25	43081	26	Washer, 5/16" STD
3-	42880	1	Engine (50 State)	26	24798	4	Boot Mounting Strap
4	43182	2	Bolt, Hex 5/16-18 x 3/4"	27	48133	1	Hard top Boot
5	43840	2	Bolt, Hex 5/16-18 x 1-1/4"	28	44790	1	Poly Rear Door
6	43085	4	Bolt, Hex 5/16-18 x 1-1/2"	29	43790	1	Strap, Tarp 25"
7	1543-69	11	Washer, Nylon 21/64"	30	44849	2	"S" Hook, #32
8	47810	18	Nut, Hex Nylock 5/16-18	31	44850	2	Strap, Tarp (Less Hooks)
9	43791	1	Hose Adapter	32	HA21362	6	Nut, Hex Nylock 3/8-16
10		1	Impeller Housing Assembly (See page 22)	33	43866	28	Bolt, Hex 1/4-20 x 5/8"
11	49983	3	Hex Nut, Flange Lock 5/16-18	34	43661	4	Bolt, Hex 1/4-20 x 1"
12	43012	13	Bolt, Hex 1/4-20 x 3/4"	35	43088	45	Washer, 1/4" STD
13	43080	2	Bolt, Carr. 5/16" x 3/4"	36	1509-90	3	Bolt, Hex 1/4-20 x 1-1/4"
14	43087	2	Hex Bolt, 3/8-16 x 1-1/4"	37	47189	51	Nut, Hex Nylock 1/4-20
15	46938	4	Hex Bolt, 3/8-16 x 3-1/4"	38	47630	4	Screw, Self Tap 5/16-18 x 3/4"
16	49974	1	Hose Hanger Rod	39	42749	1	"S" Hook, Large
17	46420	1	Elbow	40	27304	1	Attachment Bracket
18	41882	1	Hose (6" x 84")	41	43830	1	Adapter, Deck
19	43793	2	Hose Clamp 6"	42	23560	1	Bracket, Deck Adapter
20	24678	2	Side Panel Cart Extension	43	23825	1	Mounting Strap
21	24679	1	Front Panel Cart Extension	44	23826	1	Angle Bracket
22	23836	1	Cross Brace	45	23827	1	Mounting Bracket
23	68606	1	Hard Top Assembly (Includes 24,25,26,27)	46	62468	1	Deck Adapter Kit (Includes parts shown in box on page 18.)
					28301	1	Owner's Manual

## REPAIR PARTS FOR MOW-N-VAC IMPELLER HOUSING ASSEMBLY MODEL 551889A

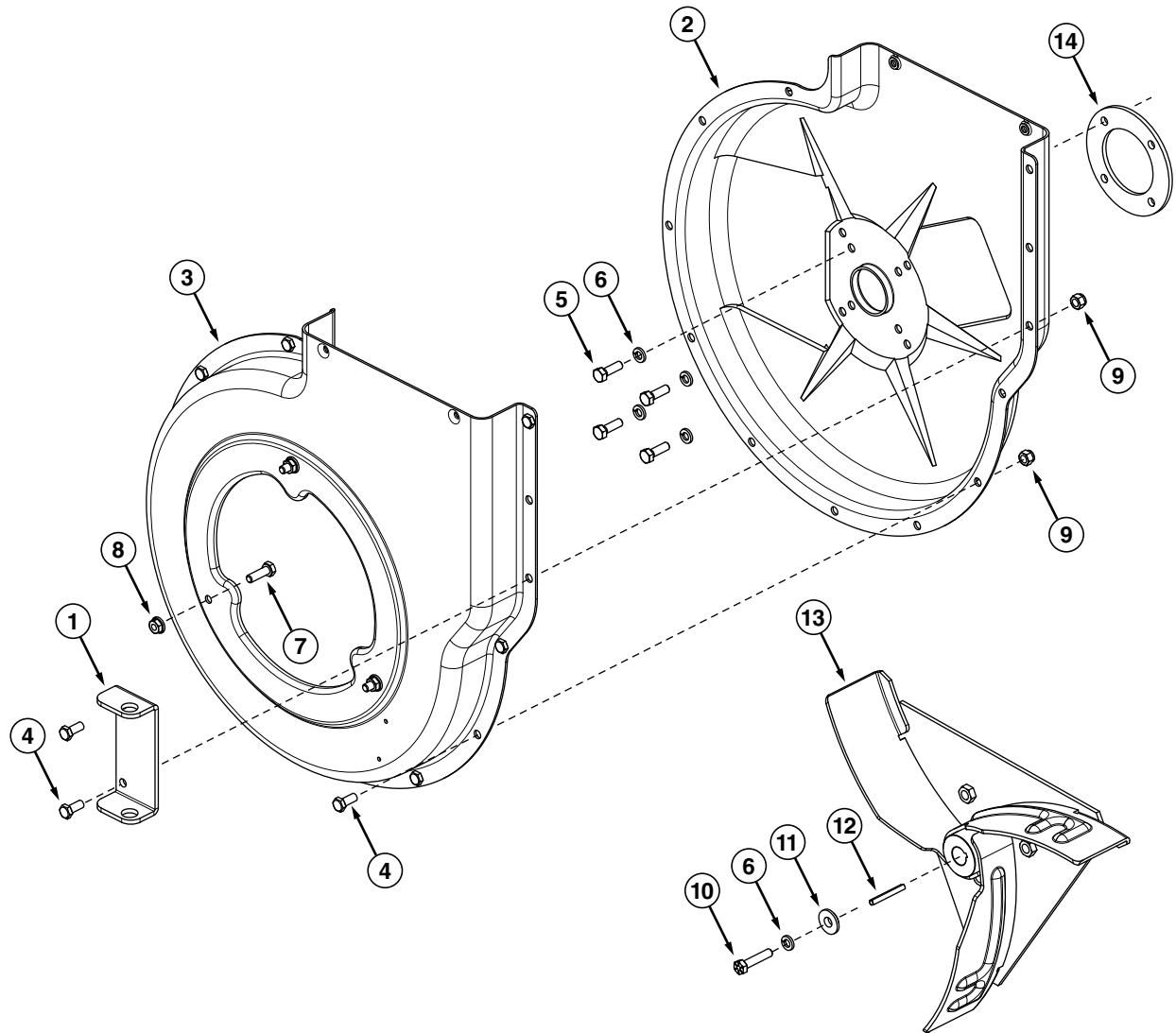



REF.	PART NO.	QTY.	DESCRIPTION	REF.	PART NO.	QTY.	DESCRIPTION
1	24958	1	Hose Hanger Bracket	8	46584	3	Nut, Whizlock 5/16-18
2	27884	1	Housing Ass'y. Inner	9	47810	12	Nut, Nylock Hex 5/16-18
3	24633	1	Housing Ass'y. Outer	10	28107	1	Bolt, Hex 5/16-24 x 1-1/2"
4	43182	12	Bolt, Hex 5/16-18 x 3/4"	11	26538	1	Spacer, Step
5	47600	4	Bolt, Hex 5/16-24 x 1"	12	HA11154	1	Key, 3/16" x 1-3/4"
6	43086	5	Lock Washer, 5/16"	13	68669	1	Impeller Assembly
7	43063	3	Bolt, Hex 5/16-18 x 1"	14	28046	1	Spacer, Inner Housing

# SLOPE GUIDE

(Keep this sheet in a safe place for future reference.)

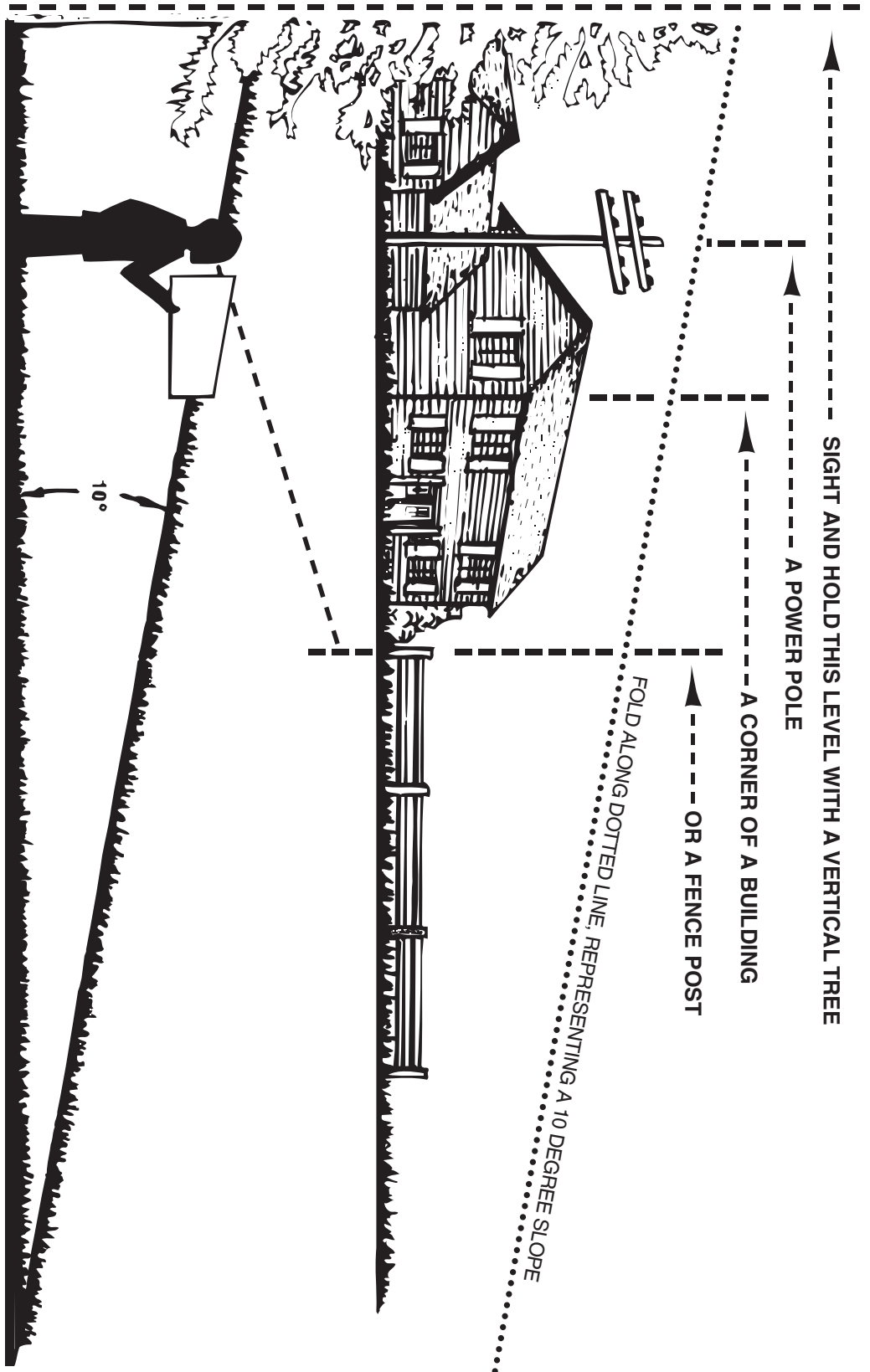
Use this guide to determine if a slope is safe for the operation of your tractor and Mow-N-Vac. Refer also to the instructions in your vehicle owners manual.



 **CAUTION:** Do not operate your tractor and Mow-N-Vac on a slope in excess of 10 degrees. Be sure of your tractor's towing and braking capabilities before operating on a slope. Avoid any sudden turns or maneuvers while on a slope.





***SpeedPart*** *the fastest way to purchase parts* [www.speedepart.com](http://www.speedepart.com)

**REPAIR PARTS**

Agri-Fab, Inc.  
303 West Raymond  
Sullivan, IL. 61951  
217-728-8388  
[www.agri-fab.com](http://www.agri-fab.com)

This document (or manual) is protected under the U.S. Copyright Laws and the copyright laws of foreign countries, pursuant to the Universal Copyright Convention and the Berne convention. No part of this document may be reproduced or transmitted in any form or by any means, electronic or mechanical, including photocopying or recording, or by any information storage or retrieval system, without the express written permission of Agri-Fab, Inc. Unauthorized uses and/or reproductions of this manual will subject such unauthorized user to civil and criminal penalties as provided by the United States Copyright Laws.