

Agri+Fab[®] **PLATINUM**

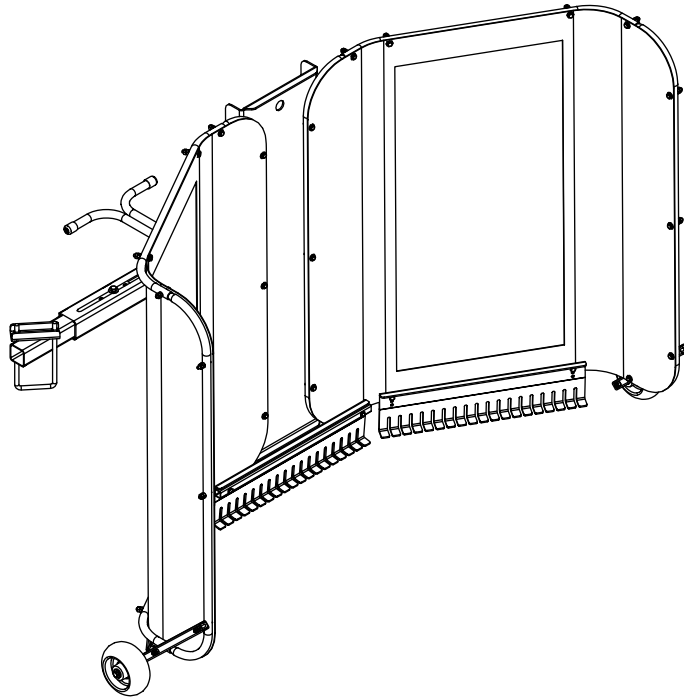

45-0550

LEAF BLADE

SAFETY RULES

Remember, any equipment can cause injury if operated improperly or if the user does not understand how to operate the equipment. Exercise caution at all times when using this equipment.

	Look for this symbol to point out important safety precautions. It means— ATTENTION! Become alert! Your safety is involved.
---	--

- NEVER allow anyone to operate the leaf blade without proper instructions.
- NEVER permit children to operate the leaf blade.
- NEVER push the leaf blade too close to a fire.
- ALWAYS wear eye protection while operating the leaf blade.
- Only use leaf blade for raking and pushing leaves.
- Refer to the vehicle owners manual for instructions on safe operation on slopes.
- Stay alert for holes, tree roots, or other hidden hazards.
- This leaf blade is NOT meant for street or highway use. Watch for traffic when raking near roadways.
- Keep all nuts and bolts tight.
- The leaf blade should be stopped and inspected for damage after striking a foreign object. Repair any damage before operating the equipment.
- Follow maintenance instructions as outlined in this manual.

NOTE: The Leaf Blade works best in conjunction with the Leaf Blower.



	NOTICE This equipment is designed for leaf removal only. Do not move other objects. Read the owner's manual for additional operating instructions.	
agri-fab.com	800-448-9282	Reorder No. 3-71

CARTON CONTENTS - PARTS

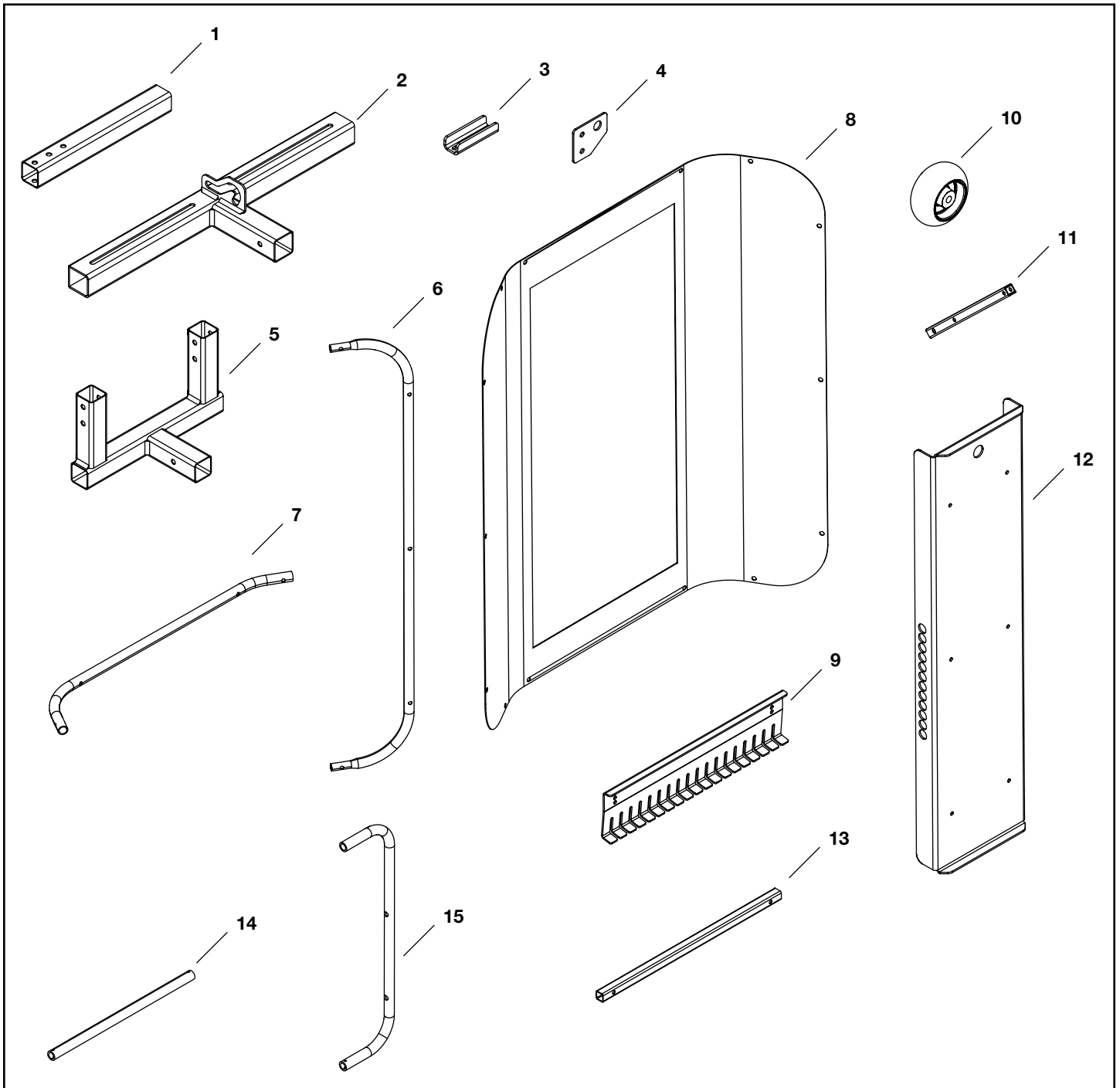

REF	QTY	PART NO	DESCRIPTION	REF	QTY	PART NO	DESCRIPTION
1	2	45814GY1	Slider Tube	9	3	45812OR1	Leaf Rake
2	1	69643GY1	Hitch Mount Assembly	10	2	48098	Anti-Scalp Wheel
3	2	45908	Mounting Bracket	11	2	2-22GY1	Wheel Support
4	4	45816GY1	Pivot Bracket	12	1	45811GY1	Bulkhead
5	1	69642GY1	Blade Mount Assembly	13	1	2-23GY1	Rake Brace
6	4	45810GY1	Vertical tube	14	1	45817GY1	Pivot Shaft
7	4	45809GY1	Horizontal tube	15	2	45823OR1	Push Tube
8	2	45808	Pusher Wall				

CARTON CONTENTS - HARDWARE

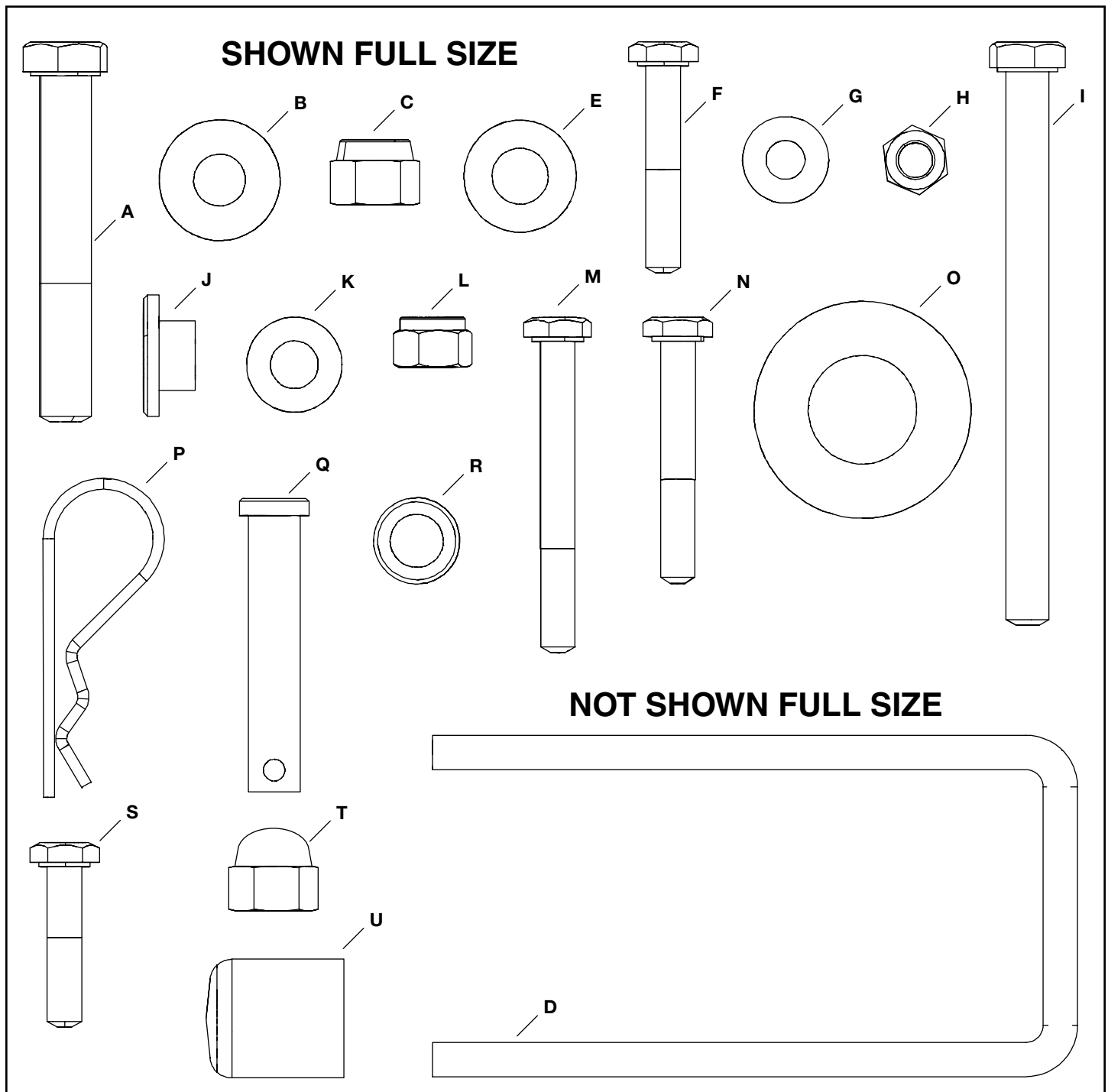

REF	QTY	PART NO	DESCRIPTION	REF	QTY	PART NO	DESCRIPTION
A	7	43432	Hex Bolt, 3/8-16 x 2-1/2 GR5	L	2	47810	Nyloc Hex Nut, .312-18
B	8	43081	Washer, .375 x .875 x .083	M	6	45164	Hex Bolt, 1/4-20 x 2-1/4 G5
C	11	HA23162	Nyloc Hex Nut, 3/8-16	N	6	1509-69	Hex Bolt, 1/4-20 x 1-3/4 GR5
D	2	45909	U-Bolt, 7.0 x 3.5 x 3/8	O	4	43009	Washer, .785 x 1.57 x 0.57
E	1	R19131316	Washer, .406 x .812 x .062	P	6	43343	Hair Cotter Pin 3/32 x 2-5/16
F	4	43648	Hex Bolt, 1/4-20 x 1-1/2 G5	Q	2	43023	Clevis Pin, 3/8 x 2
G	22	736-0142	Washer, .281 x .625 x .065	R	1	23625	Spacer, .308ID x .620OD x .270
H	44	43013	Hex Nut, 1/4-20 LOC	S	12	1509-90	Hex Bolt, 1/4-20 x 1-1/4
I	2	47407	Hex Bolt, 5/16-18 x 4 GR6	T	12	48236	Acorn Hex Nut, 1/4-20
J	4	1657-5	Step Bushing	U	2	44688	Cap, 3/4" ID Vinyl
K	2	48015	Nylon Washer, .345 x .69 x .06				

ASSEMBLY INSTRUCTIONS

TOOLS REQUIRED FOR ASSEMBLY

- (1) Adjustable Wrench
- (2) 7/16" Wrenches
- (2) 1/2" Wrenches
- (2) 9/16" Wrenches

Lay out and identify the parts and hardware using the illustrations on page 3 and page 4.

ASSEMBLE THE HITCH MOUNT ASSEMBLY

STEP 1: (SEE FIGURE 1)

- Insert a slider tube (1) into each end of the hitch mount assembly (2)
- Attach the slider tube to the hitch mount assembly using two hex bolts (A), washers (B), and Nyloc hex nuts (C). Do not tighten.

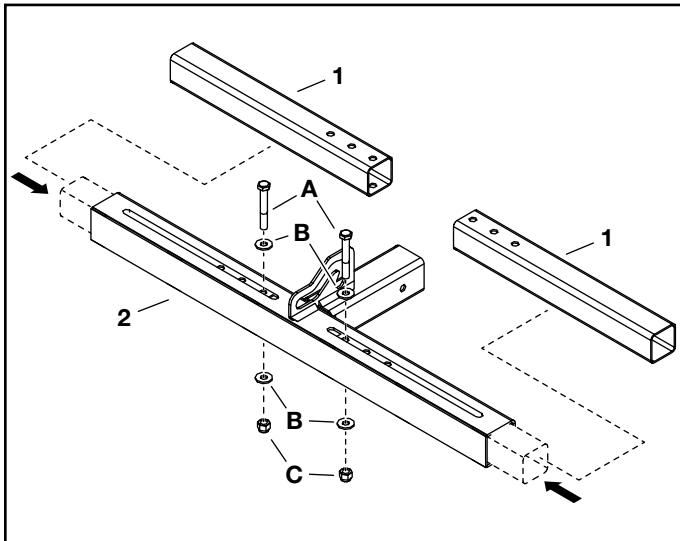

FIGURE 1

STEP 2: (SEE FIGURE 2)

- Attach the hitch mount assembly (2) to the tractor frame using two U-bolts (D) secured with two mounting brackets (3), four washers (B), and four Nyloc hex nuts (C). Do not tighten.
- If the slider tube does not fully extend into both U-bolts (D), then loosen the appropriate hex bolt (A) and reposition the slider tube (1).
- Center the hitch mount assembly on the tractor frame.
- Tighten all hex bolts.

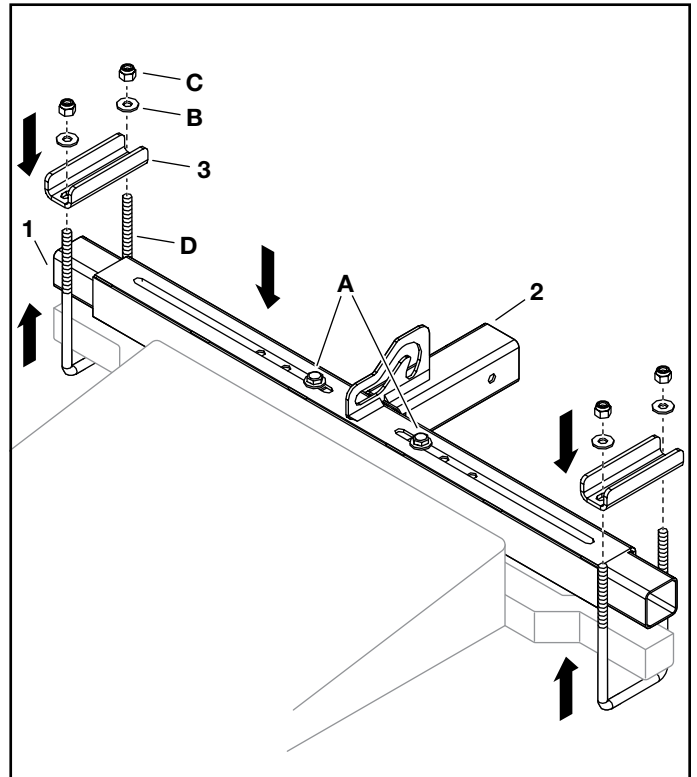

FIGURE 2

ASSEMBLE THE BLADE MOUNT ASSEMBLY

STEP 3: (SEE FIGURE 3)

- Attach four pivot brackets (4) to the blade mount assembly (5) using four hex bolts (A) and Nyloc hex nuts (C).
- To help align the pivot brackets (4), temporarily insert the pivot shaft (14) through the holes in the pivot brackets.
- Remove the pivot shaft (14) once the pivot brackets (4) are securely attached to the blade mount assembly (5).

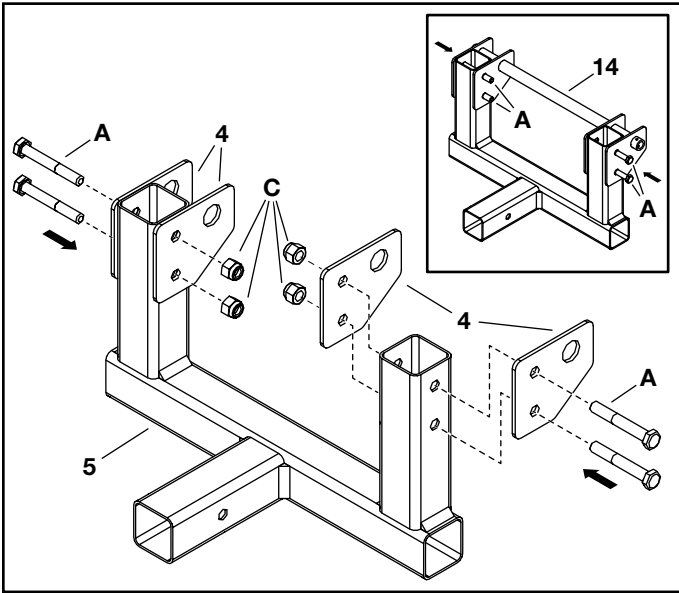

FIGURE 3

ATTACH THE BLADE MOUNT ASSEMBLY TO THE HITCH MOUNT ASSEMBLY

STEP 4: (SEE FIGURE 4)

- Insert the blade mount assembly (5) into the hitch mount assembly tube (2).
- Secure with a hex bolt (A), washer (E), and Nyloc hex nut (C).

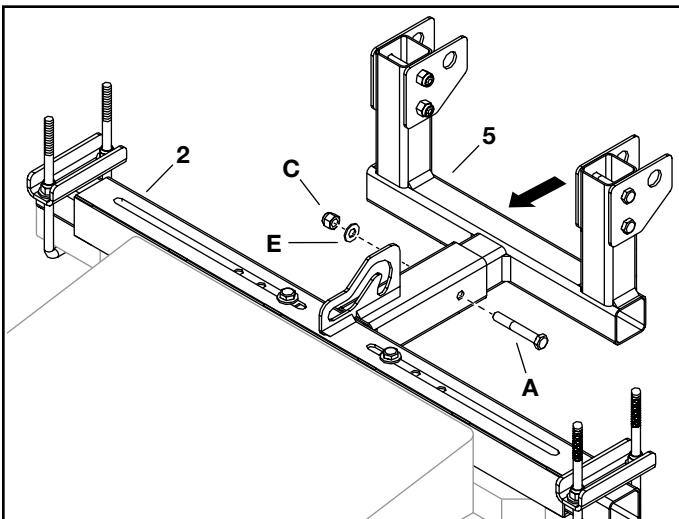

FIGURE 4

ASSEMBLE THE PUSHER WALL ASSEMBLIES

STEP 5: (SEE FIGURE 5)

- Assemble the pusher wall frame by inserting two vertical tubes (6) into two horizontal tubes (7), making sure the curvature of the horizontal tubes match.
- Repeat to assemble the second frame.

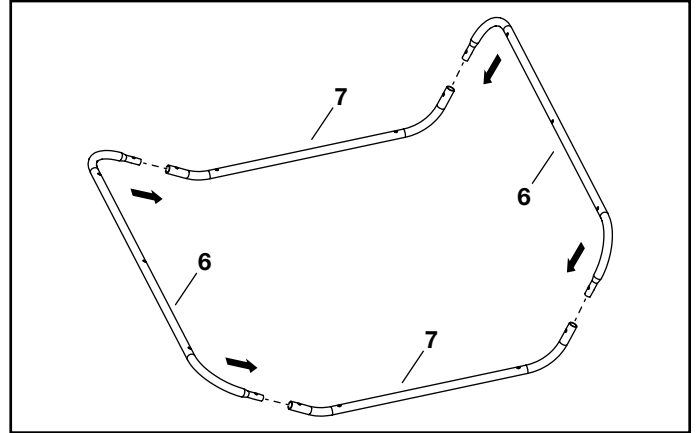

FIGURE 5

STEP 6: (SEE FIGURE 6)

- With the assembled frame lying flat and the greater angle to the right, place a pusher wall (8) on top with the stitching facing the frame.
- Align the pusher wall holes with the holes in the frame and attach using six hex bolts (S), washers (G), and hex nuts (H) in the holes shown.
- Make sure the two hex bolts on the vertical part of the frame are on the side with the greater angle as shown.
- Tighten the six hex nuts.
- Add an acorn hex nut (T) to each hex bolt and tighten. This is now the right pusher wall assembly with the hex bolts at the top.

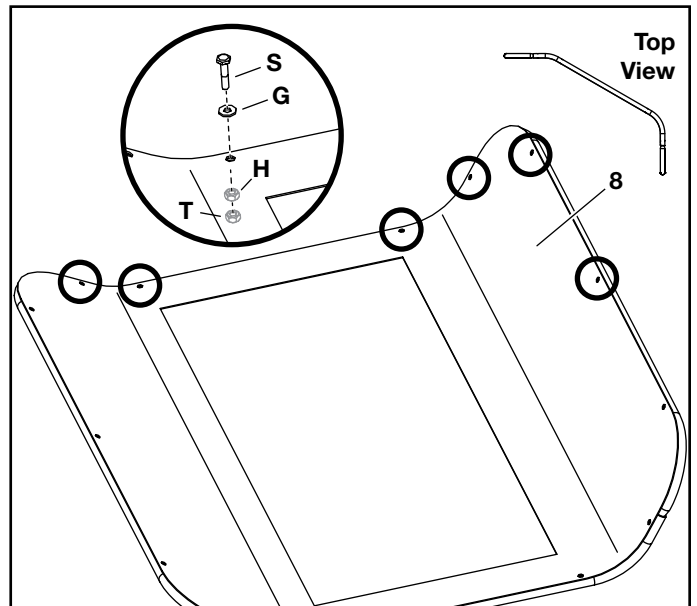

FIGURE 6

STEP 7: (SEE FIGURE 7)

- With the second assembled frame lying flat and the greater angle to the left, place a pusher wall (8) on top with the stitching facing the frame.
- Align the pusher wall holes with the holes in the frame and attach using six hex bolts (S), washers (G), and hex nuts (H) in the holes shown.
- Make sure the two hex bolts on the vertical part of the frame are on the side with the greater angle as shown.
- Tighten the six hex nuts.
- Add an acorn hex nut (T) to each hex bolt and tighten. This is now the left pusher wall assembly with the hex bolts at the top.

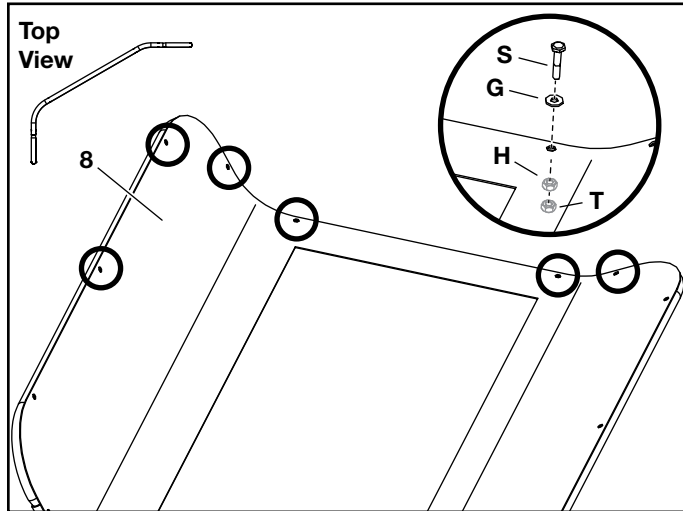

FIGURE 7

ATTACH THE LEAF RAKES TO THE PUSHER WALL ASSEMBLIES

STEP 8: (SEE FIGURE 8)

- With the right pusher wall assembly lying flat, attach a leaf rake (9) to the bottom of the pusher wall assembly using two hex bolts (F), and hex nuts (H).
- Select the holes in the leaf rake (9) that works best for your tractor height.
- Make sure the hex bolts secure the pusher wall fabric.
- Tighten the hex nuts (H).
- Add a second hex nut (H) to each bolt and tighten.
- Repeat step 8 with a leaf rake (9) and the left pusher wall.

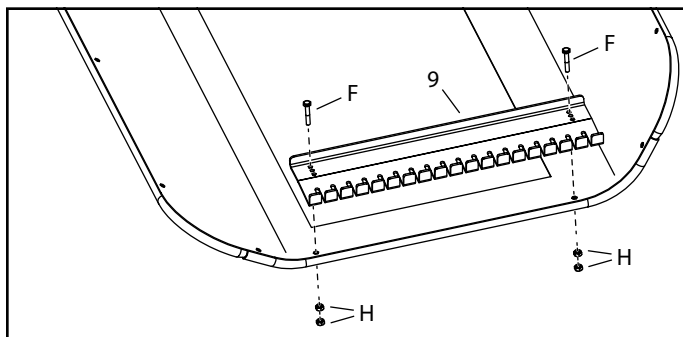

FIGURE 8

ASSEMBLE AND ATTACH THE WHEELS

STEP 9: (SEE FIGURE 9)

- Attach the wheel (10) to the bottom hole in a wheel support (11) using a hex bolt (I), two step bushings (J), a washer (K), and a hex nut (L).
- Tighten, but not too tight. The wheel should rotate easily.
- Repeat with the second wheel and wheel support.

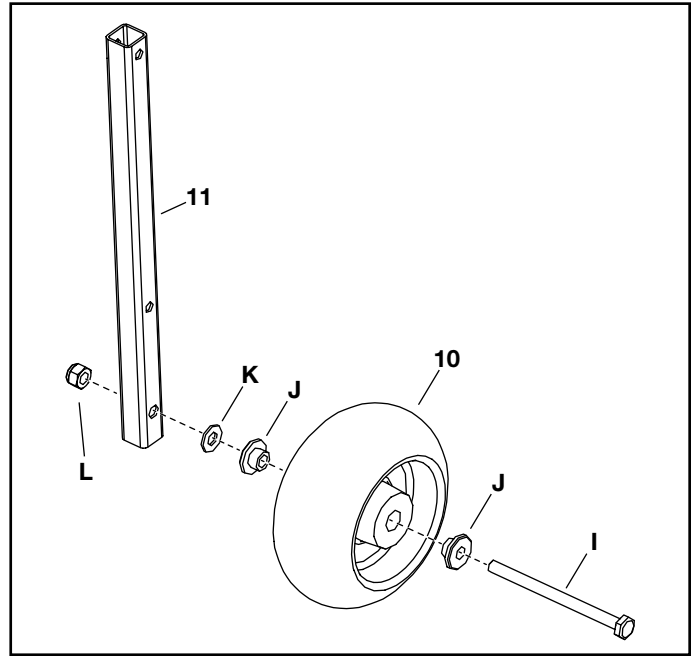

FIGURE 9

STEP 10: (SEE FIGURE 10)

- With the right pusher wall assembly lying flat, attach a wheel support (11) to the assembly using two hex bolts (M), washers (G), and hex nuts (H).
- Make sure the wheel support is attached to the side of the pusher wall assembly with the greater angle.
- Make sure the hex bolts secure the pusher wall fabric.
- Tighten the hex nuts (H).
- Add a second hex nut (H) to each hex bolt and tighten.
- Repeat step 10 to attach the other wheel support to the left pusher wall assembly.

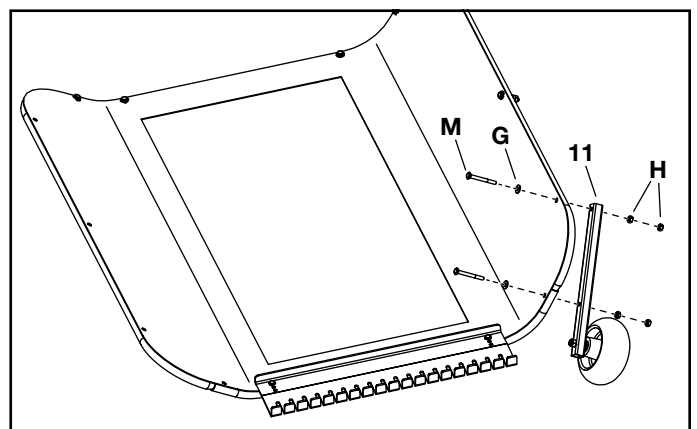

FIGURE 10

ATTACH THE PUSHER WALLS TO THE BULKHEAD

STEP 11: (SEE FIGURE 11)

- Stand the left pusher wall assembly (8) upside down as shown.
- Stand the bulkhead (12) upside down with the hole closer to the ground and the flat side against the left side (less angle) of the pusher wall assembly.
- Attach the left pusher wall assembly to the bulkhead (12) using three hex bolts (N), washers (G), and hex nuts (H) and tighten.
- Add a second hex nut (H) to each hex bolt and tighten.

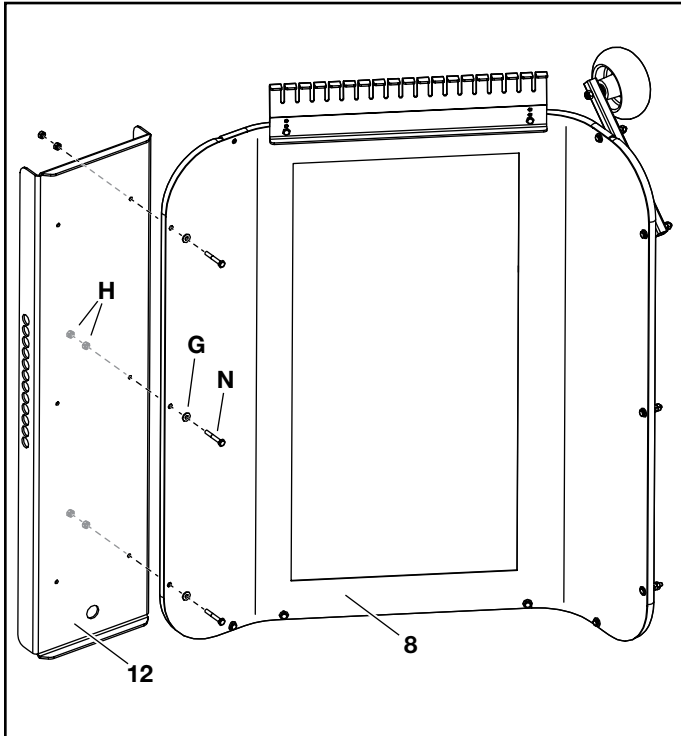

FIGURE 11

STEP 12: (SEE FIGURE 12)

- Stand the right pusher wall assembly (8) upside down as shown.
- Make sure the right side (less angle) of the pusher wall assembly is against the bulkhead.
- Attach the right pusher wall assembly to the bulkhead (12) using three hex bolts (N), washers (G), and hex nuts (H) and tighten.
- Add a second hex nut (H) to each hex bolt and tighten.

TIP: Turn the entire pusher wall assembly with the attached bulkhead right side up to install the hex bolt (N) closest to the hole in the bulkhead.

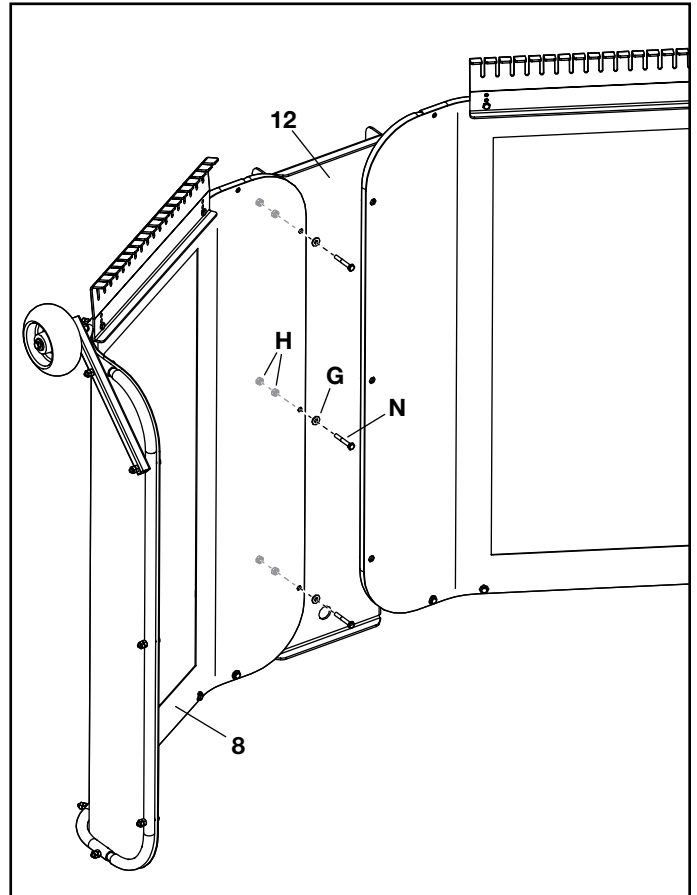

FIGURE 12

ATTACH THE LEAF RAKE TO THE BULKHEAD

STEP 13: (SEE FIGURE 13)

- Lay the bulkhead with the pusher wall assemblies flat.
- Place the rake brace (13) on the leaf rake (9), aligned to the top of the leaf rake.
- Attach the leaf rake (9) and rake brace (13) to the bottom of the bulkhead (12) using two hex bolts (M), and hex nuts (H) and tighten.
- Add a second hex nut (H) to each hex bolt and tighten.

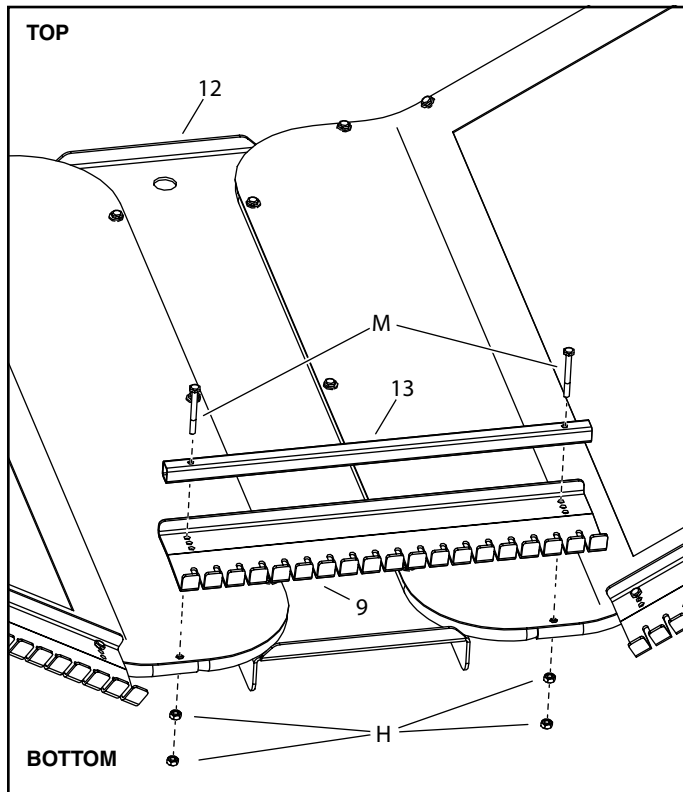

FIGURE 13

ATTACH THE PIVOT ASSEMBLY TO THE BULKHEAD

STEP 14: (SEE FIGURE 14)

- While holding the pusher wall assembly up to the blade mount assembly (5), insert the pivot shaft (14) through the two sets of pivot brackets (4) and the holes in the bulkhead (12).

NOTE: The holes to use in the bulkhead are determined by your tractor height.

- Make sure the leaf rakes are not resting on the ground. If they are, then raise the pivot shaft (14) up one hole in the bulkhead (12).
- Secure each end of the pivot shaft (14) using a washer (O) and a hair cotter pin (P).

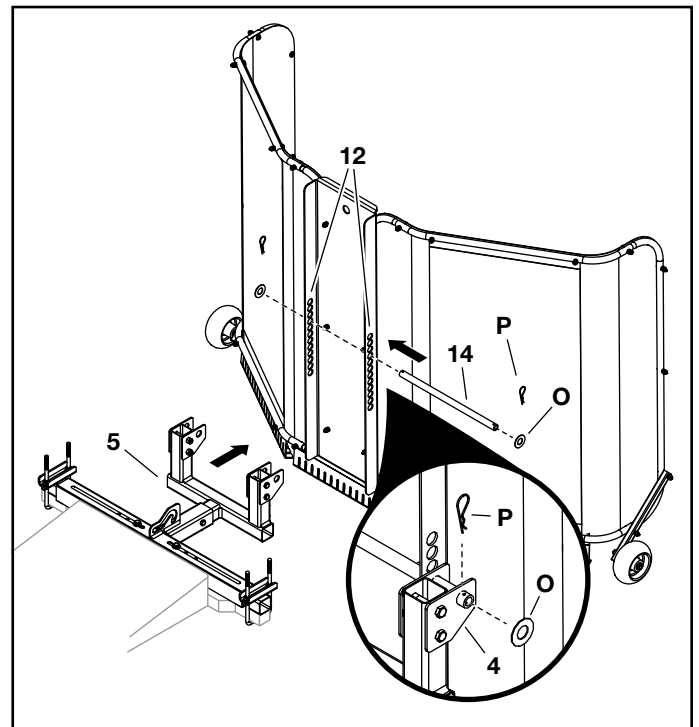

FIGURE 14

ATTACH PUSH TUBES TO THE BULKHEAD

STEP 15: (SEE FIGURE 15)

- With a push tube (15) level to the hitch mount assembly (2), insert the uncapped end of the push tube into the bulkhead (12) hole at that height.
- Repeat with the second push tube.
- Secure each push tube to the bulkhead using a washer (O) and hair cotter pin (P).

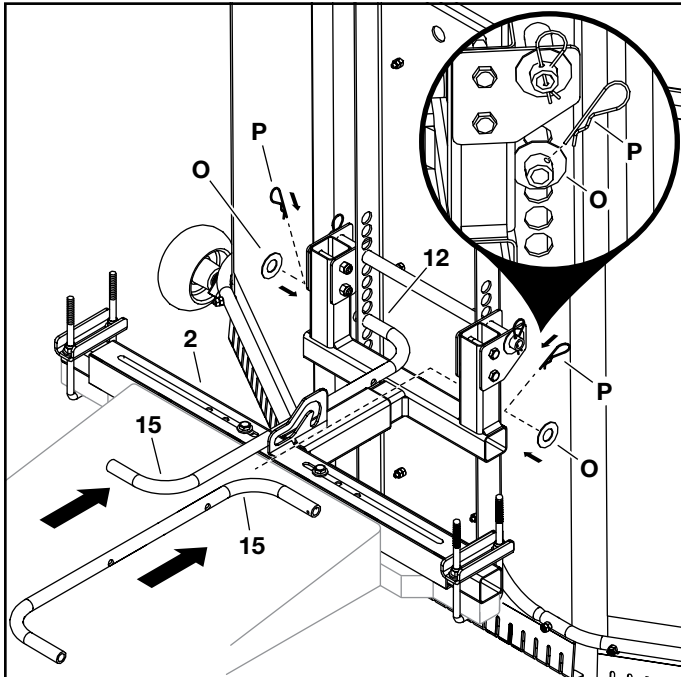

FIGURE 15

STEP 16: (SEE FIGURE 16)

- Attach the two push tubes (15) together using a clevis pin (Q) and a spacer (R) between the push tubes at the end closest to the bulkhead.
- Insert a second clevis pin through the opposite side of the push tubes at the end furthest from the bulkhead.
- Secure each clevis pin using a hair cotter pin (P).

Note: We recommend the two hair cotter pins (P) be on opposite sides of the push tubes (15).

- Push a cap (U) onto the end of each push tube.

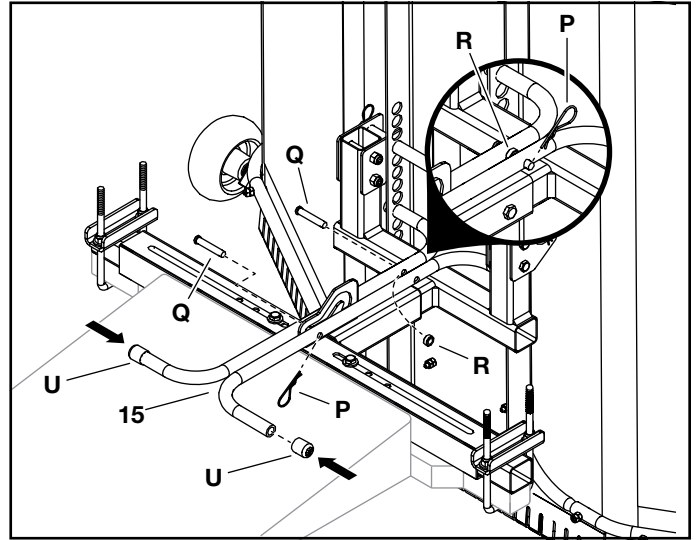

FIGURE 16

OPERATION



CAUTION: Failure to obey the following cautions could result in personal injury or product damage:

- Securely position your feet on the push tube handles when engaging or disengaging the leaf blade assembly.
- Do **NOT** take your feet off the push tube handles until the leaf blade assembly is either fully locked into the disengage position or fully released to the engage position.
- Do **NOT** allow the leaf blade assembly to fall over when upright.

Take care when operating your leaf blade. Operating your leaf blade according to these instructions will help prevent damage and prolong the life of your leaf blade.

- Refer to the vehicle owners manual for instructions on safe operation on slopes.
- For best handling and traction, distribute the weight of the load evenly on the pusher walls.
- The maximum pushing speed for this leaf blade assembly is 7 m.p.h.
- Watch out for exposed tree roots, as they can cause damage to the leaf blade.
- For best results, always mow the grass to an even height before using the leaf blade.
- Works best in conjunction with the leaf blower.

ENGAGE THE LEAF BLADE ASSEMBLY

1. Sit on the tractor so that your feet can reach the push tube handles.
2. When engaging the leaf blade assembly, be prepared for the weight of the pusher walls to push against your feet.
3. Use your feet to slightly push and lift the push tube handles until the leaf rakes and wheels are on the ground.

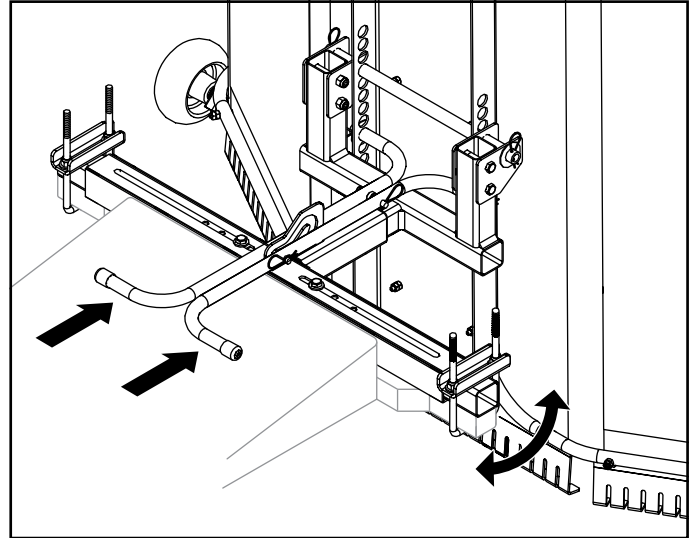

FIGURE 17

DISENGAGE THE LEAF BLADE ASSEMBLY

1. Sit on the tractor so that your feet can reach the push tube handles.
2. When disengaging the leaf blade assembly, be prepared to push the weight of the pusher walls.
3. Use your feet to push the push tube handles until the leaf rakes and wheels pivot up off the ground and the clevis pin locks into place.

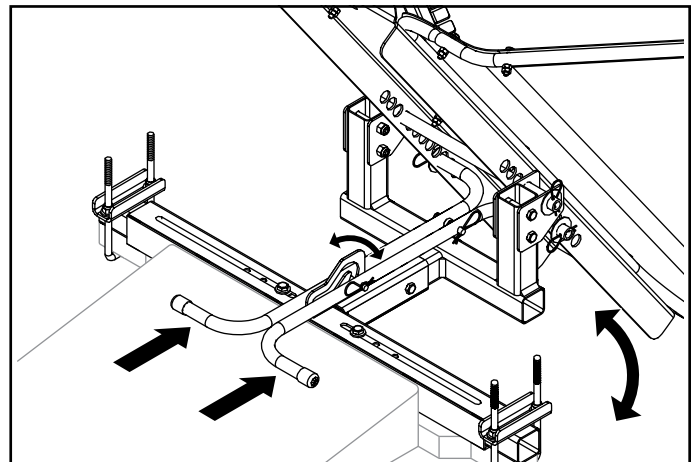

FIGURE 18

ADJUST THE LEAF BLADE HEIGHT

NOTE: If using the leaf blade on uneven terrain, raise the leaf blade assembly one hole higher to prevent damage to the unit.

1. Engage the leaf blade assembly so that the wheels are on the ground (see "Disengage the Leaf Blade Assembly" on page 11).
2. Remove the hair cotter pins (P) and washers (O) securing the pivot shaft. Retain for reassembly.
3. Remove the hair cotter pins (P), clevis pins (Q), and spacer (R) securing the push tubes together. Retain for reassembly.
4. Remove and reinsert the pivot shaft into the bulkhead holes to achieve the desired height for your tractor.
5. Secure the pivot shaft to the bulkhead using the removed washers (O) and hair cotter pins (P). (See STEP 14 on page 9 for instructions.)
6. Reassemble the push tubes and secure with the removed spacer (R), clevis pins (Q), and hair cotter pins (P). (See STEP 15 and STEP 16 on page 10 for instructions.)

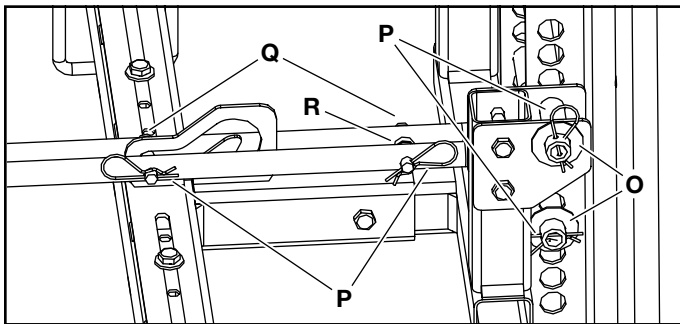

FIGURE 19

STORAGE

To store, remove the push wall assembly from the hitch mount assembly.

- Engage the leaf rake so that the wheels are on the ground. (See "Engage the Leaf Blade Assembly" on page 11 for instructions.)
- Remove the hair cotter pin (P) and clevis pin (Q) from the push tubes at the end furthest from the bulkhead.
- Remove the hex nut (C), washer (E), and hex bolt (A) that attaches the blade mount assembly to the hitch mount assembly.
- Pull the push wall assembly to slide the blade mount assembly out of the hitch mount assembly tube.
- Hang the push wall assembly on the wall to store.

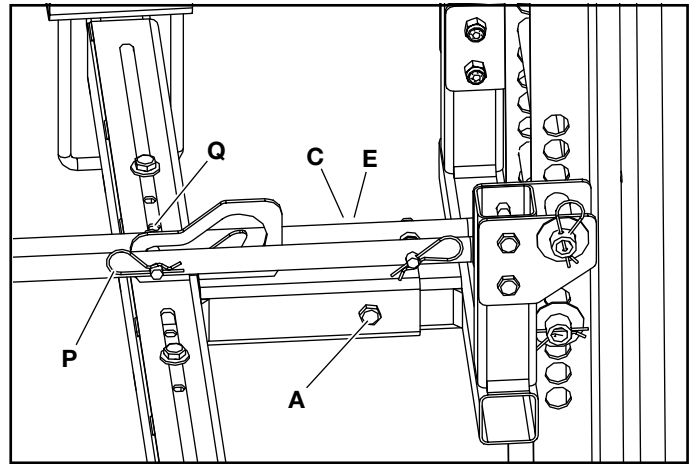

FIGURE 20

MAINTENANCE

- Always clean the leaf blade assembly after each use. Damp or wet grass and leaves will cause damage to the leaf blade assembly if stored for long periods of time.
- Check periodically for loose bolts.
- At the beginning of each season, using a light machine oil, lubricate the pivot points.

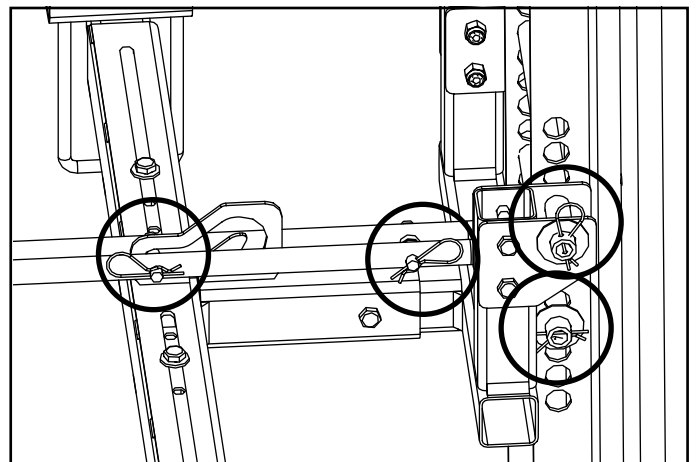
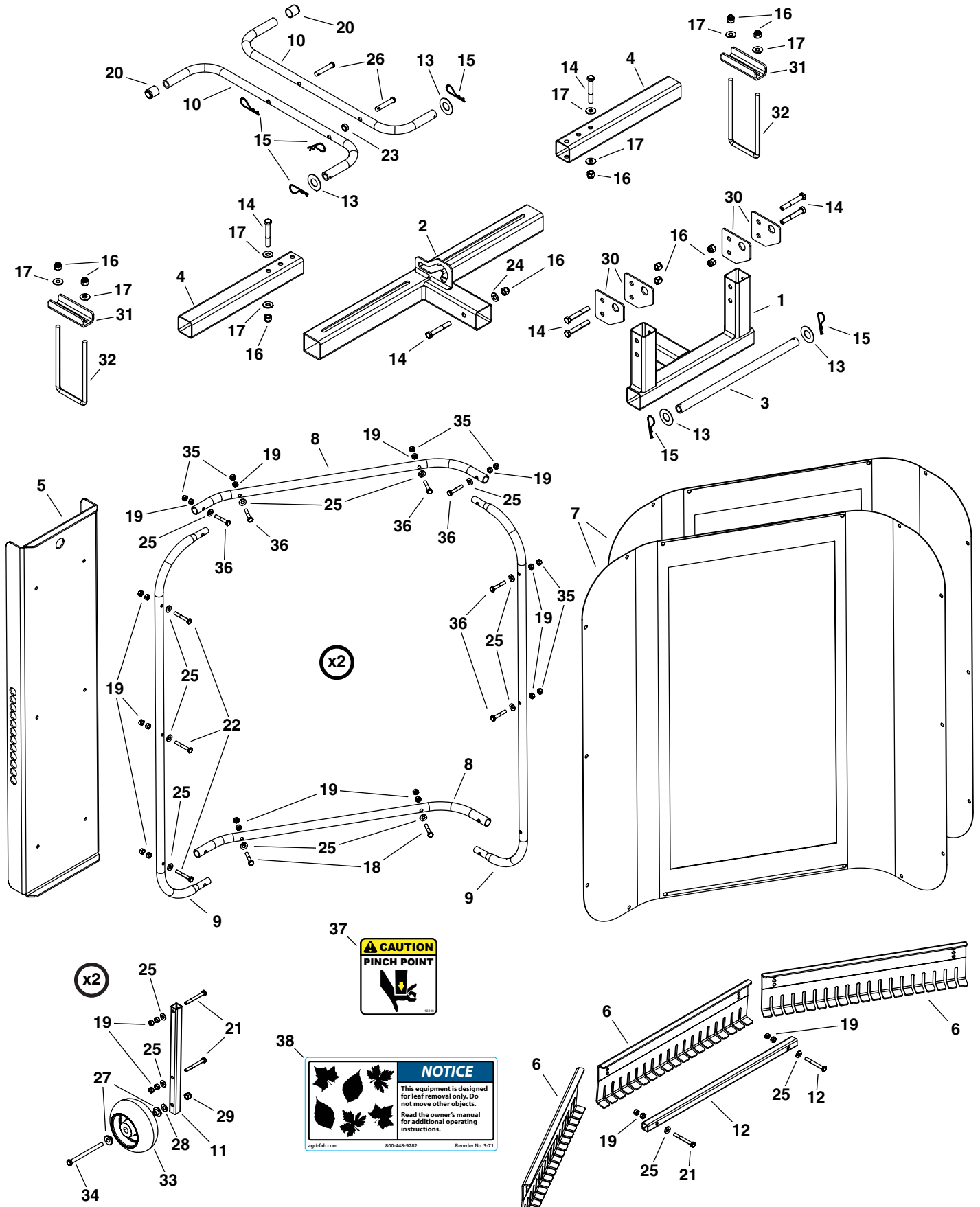

FIGURE 21

This page intentionally left blank.

REPAIR PARTS FOR 45-0550 LEAF BLADE



REPAIR PARTS FOR 45-0550 LEAF BLADE

REF	QTY	PART NO	DESCRIPTION	REF	QTY	PART NO	DESCRIPTION
1	1	69642GY1	ASS'Y, BLADE MOUNT (WLDMNT)	21	6	45164	BOLT, HEX 1/4-20 X 2-1/4 G5
2	1	69643GY1	ASS'Y, HITCH MOUNT (WLDMNT)	22	6	1509-69	BOLT, HEX 1/4-20 X 1-3/4 GR5
3	1	45817GY1	SHAFT, PIVOT	23	1	23625	SPACER, .380ID X .620OD X .270
4	2	45814GY1	TUBE, SLIDER	24	1	R19131316	WASHER, .406 X .812 X .062
5	1	45811GY1	BULKHEAD	25	22	736-0142	WASHER, .281 X .625 X .065
6	3	45812OR1	LEAF RAKE	26	2	43023	PIN, CLEVIS 3/8 X 2
7	2	45808	PUSHER WALL	27	4	1657-5	STEP BUSHING
8	4	45809GY1	TUBE, HORIZONTAL	28	2	48015	WASHER, NYLON .345 X .69 X .06
9	4	45810GY1	TUBE, VERTICAL	29	2	47810	NUT, HEX .312-18 NYLOC
10	2	45823OR1	TUBE, PUSH	30	4	45816GY1	BRACKET, PIVOT
11	2	2-22GY1	WHEEL SUPPORT	31	2	45908GY1	BRACKET, MOUNTING
12	1	2-23GY1	RAKE BRACE	32	2	45909	U-BOLT, 7.0 X 3.5 X 3/8
13	4	43009	WASHER, .785 X 1.57 X .057	33	2	48098	WHEEL, ANTI SCALP
14	7	43432	BOLT, HEX 3/8-16 X 2-1/2 GR5	34	2	47407	BOLT, HEX 5/16-18 X 4 GR5
15	6	43343	PIN, HAIR COTTER 3/32 X 2-5/16	35	12	48236	ACORN HEX NUT, 1/4-20
16	11	HA21362	NUT, HEX 3/8-16 NYLOC	36	12	1509-90	HEX BOLT, 1/4-20 x 1-1/4
17	8	43081	WASHER, .375 X .875 X .083	37	1	40240	LABEL, PINCH POINT
18	4	43648	BOLT, HEX 1/4-20 X 1-1/2 G5	38	1	3-71	LABEL, NOTICE
19	44	43013	NUT, HEX 1/4-20 LOC		1	3-53	OWNERS MANUAL
20	2	44688	CAP, 3/4" ID VINYL				

SpeedPart *the fastest way to purchase parts* www.speedepart.com

REPAIR PARTS

Agri-Fab, Inc.
809 South Hamilton
Sullivan, IL. 61951
217-728-8388
www.agri-fab.com

This document (or manual) is protected under the U.S. Copyright Laws and the copyright laws of foreign countries, pursuant to the Universal Copyright Convention and the Berne convention. No part of this document may be reproduced or transmitted in any form or by any means, electronic or mechanical, including photocopying or recording, or by any information storage or retrieval system, without the express written permission of Agri-Fab, Inc. Unauthorized uses and/or reproductions of this manual will subject such unauthorized user to civil and criminal penalties as provided by the United States Copyright Laws.