



JOHN DEERE

# Product Services Information

## INSTALLATION INSTRUCTIONS



JOHN DEERE

### DOUBLE BUCKET HOLDER

---

#### Parts in Kit

Qty.	Description
1	Mounting Frame
2	Brace, Side
1	Brace, Center
1	Spring Locking Pin, Large
2	Spring Locking Pin, Small
6	Carriage Bolt, 1/4 x 3/4-in.
6	Locknut, Serrated, 1/4-in.
2	Drilled Pin, M16
2	Drilled Pin, 1/2 in.

**NOTE: Retain these installation instructions with your machine operator's manual.**

#### Parking Safely

1. Stop machine on a level surface, not on a slope.
2. Disengage mower blades or any other attachments.
3. Lower attachments to the ground.
4. Lock the park brake.
5. Stop the engine.
6. Remove the key.
7. Wait for engine and all moving parts to stop before you leave the operator's seat.
8. Close fuel shut-off valve, if your machine is equipped.
9. Disconnect the negative battery cable or remove the spark plug wire (for gasoline engines) before servicing the machine.

#### Install Bucket Holder

**NOTE: The bent flange at the front of the mounting frame weldment will be angled downward when properly oriented for assembly.**

**Also, the two side brackets are identical. The scalloped cutout on the longer arm of each bracket will face up on one side, and down on the other side, after assembly.**

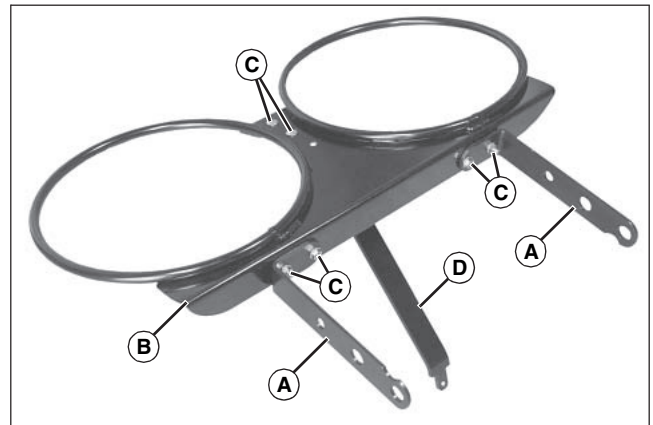

MX38475

1. Assemble the two side braces (A) to the front side of the mounting frame (B), with the shorter arm of each side brace facing inward. Secure each bracket with two 1/4 x 3/4 in. carriage bolts (C), installed from the rear, and two 1/4 in. serrated locknuts at the front of the brackets. Do not tighten.

2. Assemble the center brace (D) to the underside of the mounting frame, with the brace angled forward. Install two 1/4 x 3/4 in. carriage bolts (C) down through the mounting frame and center brace, and secure below with two 1/4 in. serrated locknuts. Do not tighten.

- For X300 and X500 series, use the two rear holes in the top of the mounting frame.
- For X700 series, use the two front holes in the top of the mounting frame.



**CAUTION:** Avoid injury! Riders can fall off and be injured or killed. Never carry riders in or on an attachment.

**IMPORTANT:** Avoid damage! Reduce speed over rough terrain when bucket is loaded to avoid loss of load, or damage to bucket or frame assembly.

**NOTE:** Maximum weight capacity of frame assembly is 18 kg (35 lb) per bucket.

**Buckets sold separately.**

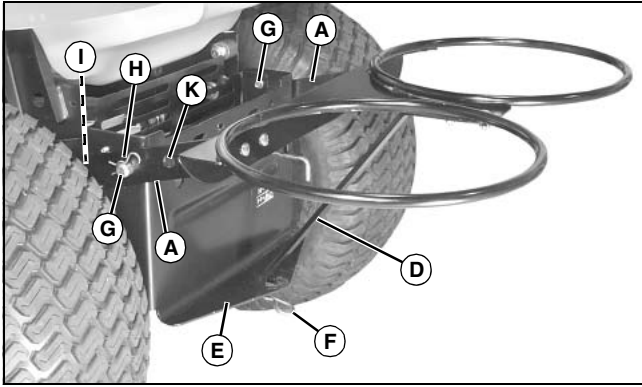

MX38487

**Picture Note:** X300 series shown.

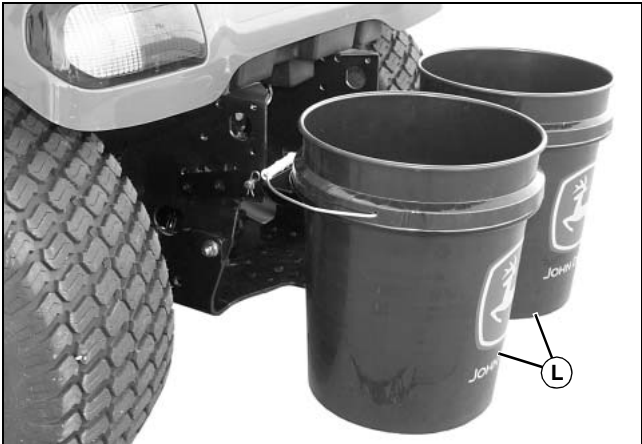

MX38477

7. Install buckets (L) into frame hoops. Buckets are sold separately. (See your John Deere dealer for availability.)

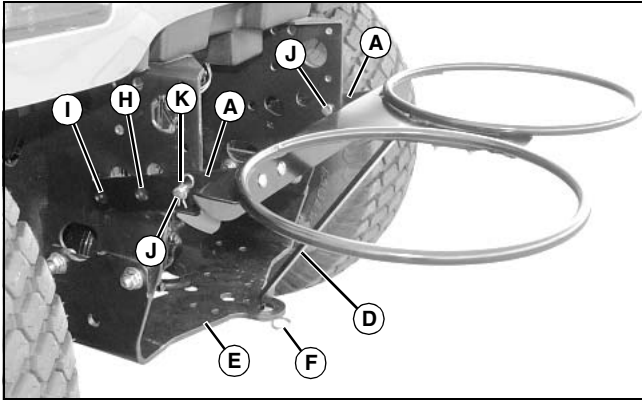

MX38488

**Picture Note:** X700 series shown.

3. Raise mounting frame into position, and place center brace (D) into hitch pin hole at rear of machine frame (E) and secure with the large spring locking pin (F).
4. Position the side braces (A) at the outside of the rear frame on the tractor, align with mounting holes, and secure:
  - For X300 series, use M16 drilled pins (G) in the rearward M16 hole (H) on side braces, and secure with small spring locking pins.
  - For X500 series, use M16 drilled pins (G) in the forward M16 hole (I) on side braces, and secure with small spring locking pins.
  - For X700 series, use 1/2 in. drilled pins (J) in the 1/2 in. hole (K) on side braces, and secure with small spring locking pins.
5. Tighten hardware securing side braces to mounting frame to 12 N•m (9 lb-ft).
6. Lift up slightly on mounting hoops, or push center brace forward in mounting slots, then tighten hardware securing center brace to mounting frame to 12 N•m (9 lb-ft).