



JOHN DEERE

INSTALLATION INSTRUCTIONS
3.5-bu Grass Catcher
LP68164

04/11/2022
English
Supplier ST50729

Introduction

Using Your Operator's Manual

Read this entire operator's manual, especially the safety information, before operating.

This manual is an important part of your machine. Keep all manuals in a convenient location so they can be accessed easily.

Use the safety and operating information in the attachment operator's manual, along with the machine operator's manual, to operate and service the attachment safely and correctly.

If your attachment manual has a section called Preparing the Machine, it means that you will have to do something to your tractor or vehicle before you can install the attachment. The Assembly and Installation sections of this manual provide information to assemble and install the attachment to your tractor or vehicle. Use the Service section to make any needed adjustments and routine service to your attachment.

If you have any questions or concerns with the assembly, installation, or operation of this attachment, see your local John Deere dealer or call the John Deere Customer Contact Center at 1-800-448-9282 for assistance.

Warranty information on this John Deere attachment can be found in the warranty that came with your John Deere tractor or vehicle.

Original instructions. All information, illustrations and specifications in this manual are based on the latest information available at the time of publication.

The right is reserved to make changes at any time without notice.

NOTE: Retain these installation instructions with the machine operators manual.

Table of Contents

Introduction	2
Product Compatibility	2
Safety Labels	3
Safety	3
Kit Includes	5
Installation	8
Assembly	6
Operation	7-8
Warranty	16

Product Compatibility

The Grass Catcher is compatible with QuikTrak™ stand-on mowers models 652E, 636M, 648M, 652M, 648R, 652R starting with model year 2016 and serial number 045001. Not compatible with 661R models

The Grass Catcher is compatible with Commercial Walk-Behind models W36R, W48R, W52R, W36M, W48M starting with model year 2019 and serial number >010001. Not compatible with W61R models.

Safety Labels

Safety Label Location



Understanding The Machine Safety Labels



The machine safety labels shown in this section are placed in important areas on your machine to draw attention to potential safety hazards.

On your machine safety labels, the words **DANGER**, **WARNING**, and **CAUTION** are used with this safety-alert symbol. **DANGER** identifies the most serious hazards.

The operator's manual also explains any potential safety hazards whenever necessary in special messages that are identified with the word, **CAUTION**, and the safety-alert symbol.

Replace missing or damaged safety labels. Use this operator's manual for correct safety label placement.

There can be more safety information contained on parts and components sourced from suppliers that is not reproduced in this operator's manual.

Warning

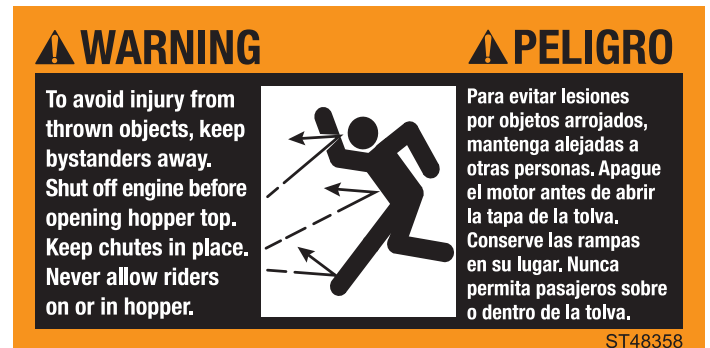

- To avoid injury from thrown objects, keep bystanders away. Shut off engine before opening hopper top. Keep chutes in place. Never allow riders on or in hopper.

Safety

Safety

Read the general safety operating precautions in your machine installation instruction manual for additional safety information.

Using Your Instruction Manual

Read this Installation Instruction manual in entirety, especially the safety information, before operating.

If your Instruction Manual has a section called Preparing the Machine, it means that you will have to do something to your tractor or vehicle before you can install the attachment. The Assembly and Installation sections of this manual provide information to assemble and install the attachment to your tractor or vehicle. Use the Service section to make any needed adjustments and routine service to your attachment.

This product was manufactured by Agri-Fab, Inc, a John Deere Licensee. If you have any questions or concerns with the assembly, installation, or operation of this attachment, see your local John Deere dealer or call Agri-Fab at 1-800-448-9282 for assistance.

Practice Safe Maintenance

- Only qualified, trained adults should service this machine.
- Understand service procedure before doing work. Keep area clean and dry.
- Do not operate or run the engine in a confined space where dangerous carbon monoxide fumes can collect.
- Never lubricate, service or adjust the machine or attachment while it is moving. Keep safety devices in place and in working condition. Keep hardware tight.
- Keep hands, feet, clothing, jewelry, and long hair away from any moving parts, to prevent them from getting caught.
- Lower any attachment completely to the ground or to an existing attachment mechanical stop before servicing the attachment. Disengage all power and stop the engine. Lock park brake and remove the key. Let machine cool.
- Disconnect battery or remove spark plug wire (for gasoline engines) before making any repairs.
- Before servicing machine or attachment, carefully release pressure from any components with stored energy, such as hydraulic components and springs.

- Release hydraulic pressure by lowering attachment or cutting units to the ground or to a mechanical stop and move hydraulic control levers.
- Securely support any machine or attachment elements that must be raised for service work. Use jack stands or lock service latches to support components when needed.
- Never run engine unless park brake is locked.
- Keep all parts in good condition and properly installed. Fix damage immediately. Replace worn or broken parts. Replace all worn or damaged safety and instruction decals.
- Check all hardware at frequent intervals to be sure the equipment is in safe working condition.
- Do not modify machine or safety devices. Unauthorized modifications to the machine or attachment may impair its function and safety

Wear Appropriate Clothing



- Always wear eye protection when operating the machine.
- Wear close fitting clothing and safety equipment appropriate for the job.
- While operating this machine, always wear substantial footwear and long trousers. Do not operate the equipment when barefoot or wearing open sandals.
- Wear a suitable protective device such as earplugs. Loud noise can cause impairment or loss of hearing.

Assembly

1. Remove handles from inside the hopper and fasten in the locations (A) shown using M6 x 18mm socket head screw, M6 washer and M6 Nylock nut.



2. Remove mounting plate from inside of the hopper and fasten in the locations (B) shown using M6 x 30mm socket head screw, M6 x 18m socket head screw, and M6 Nylock nut.

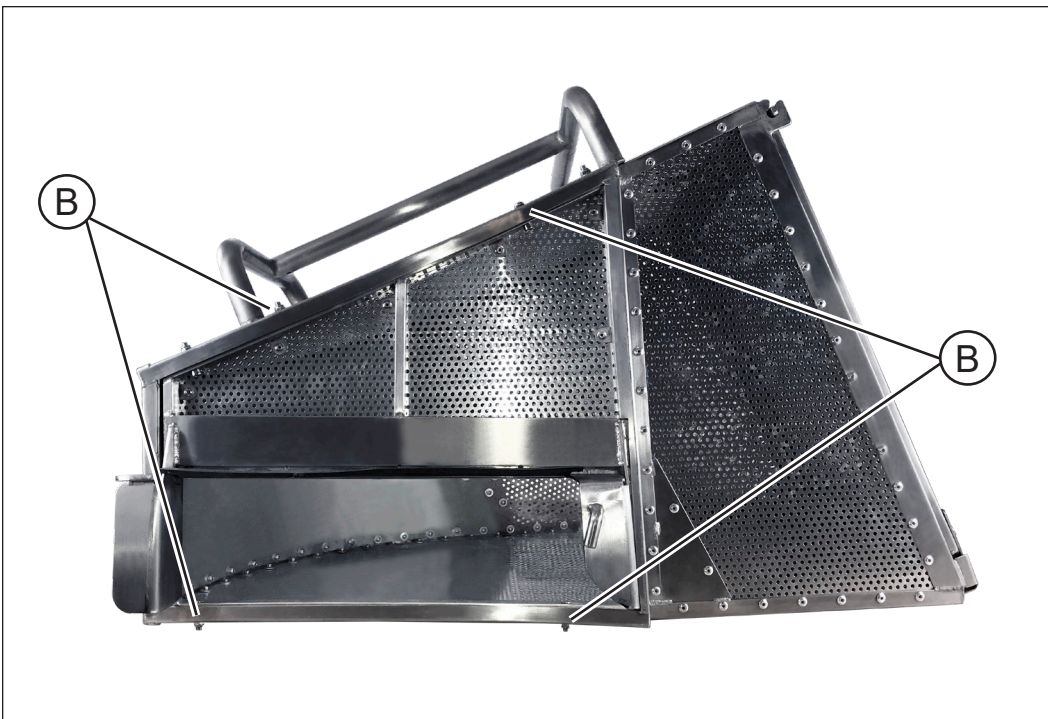

Operation

NOTE: Never operate with the discharge deflector raised, removed, or altered, unless using a grass catcher. Do not operate mower without discharge chute or entire grass catcher in place.



CAUTION: Avoid injury! Rotating blades can throw objects or debris. Do not operate mower without discharge chute or entire grass catcher in place.

Park Safely

1. Stop machine on level surface.
2. Disengage mower blades.
3. Lock the parking brake.
4. Stop the engine.
5. Remove key.
6. Wait for engine and all moving parts to stop.

Installation

1. Park machine safely.
2. Raise the mower deck discharge chute.
3. Insert hook (A) on top of the mower deck behind the tab (B) at the front of the discharge opening.
4. Lift rear of hopper to insert pin (C) into slot (D) on the rear side of the discharge opening.

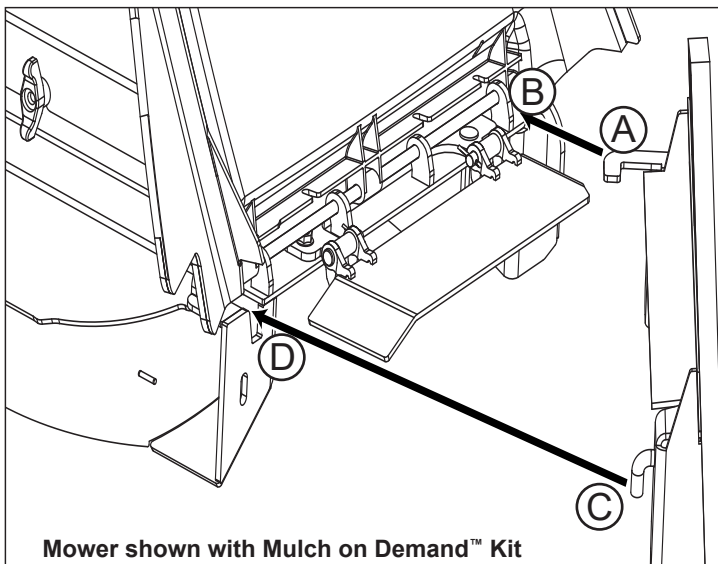

For Commercial Walk-behind Mowers:

Some conditions such as wet conditions or hillsides may cause the trim side of the deck to become light due to the weight of hopper when filling.

The cotter pin can be installed into the left rear HOC rod (E) below the vehicle frame to help keep the deck level.

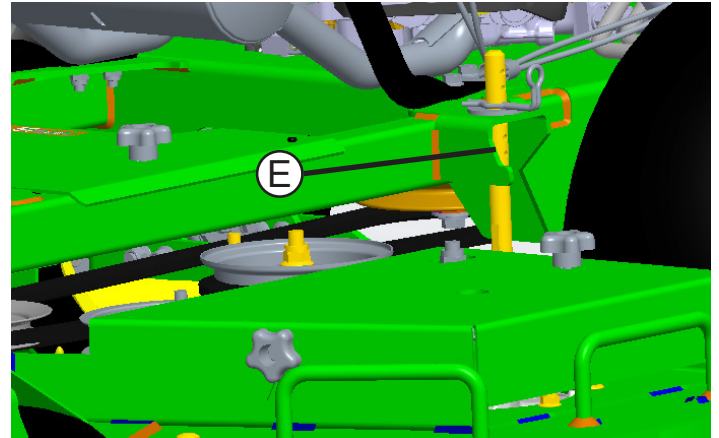

Operation

Removal

1. Park machine safely.
2. Remove hopper.
3. Lift the rear of the hopper to disengage the rear pin and slide the hopper forward to disengage the front hook. Lift away from the mower deck.

Unload Hopper



CAUTION: Avoid injury! Rotating blades can throw objects or debris. Do not operate mower without discharge chute or entire grass catcher in place.

1. Lift latch and swing door open. Door may be removed.
2. Dump material from hopper.
3. Reinstall door and resecure hatch.

Warranty

Limited Warranty for New John Deere Licensed Products

The Agri-Fab 3.5-bu. Grass Catcher is guaranteed to be free from defects in material and workmanship from the date of purchase for 2 years residential use, 6 months commercial use, provided that the purchaser properly assembles, installs, uses and maintains the products in accordance with this manual.

Purchaser's failure to adhere to such requirements will void the warranty. To the extent permitted by applicable law, all other warranties, representations, obligations and conditions, expressed or implied, including but not limited to implied warranties of merchantability, fitness for any particular purpose and non-infringement, are hereby disclaimed and excluded.

Any product which does not meet warranty shall, as purchaser's sole and exclusive remedy, be repaired or replaced by Agri-Fab. This warranty is non transferable.

In addition, our warranty does not cover:

- Labor charges
- Loss or consequential, incidental or special damages of any kind

This product was manufactured by Agri-Fab, Inc, a John Deere Licensee. If you have any questions or concerns with the assembly, installation, or operation of this attachment, see your local John Deere dealer or call Agri-Fab at 1-800-448-9282 for assistance.

