

**LP53766**

**60 Gallon Wheeled Sprayer**



**JOHN DEERE**

**OPERATOR'S MANUAL**

**60 Gallon Sprayer**

**ST43879 04/11/22 (ENGLISH)**

**North American Edition  
Printed in U.S.A**

---

---

# Introduction

---

---

## Table of Contents

Introduction.....	1
Product Identification.....	1
Safety .....	2
Assembly.....	5
Installing .....	6
Preparing Vehicle .....	7
Removing and Storing.....	7
Operating.....	7
Service .....	10
Troubleshooting .....	11
Specifications .....	11
Getting Quality Service .....	11
Warranty.....	12

---

---

## Introduction

### Using Your Operator's Manual

Read this entire operator's manual, especially the safety information, before operating.

This manual is an important part of your machine. Keep all manuals in a convenient location so they can be accessed easily.

Use the safety and operating information in the attachment operator's manual, along with the machine operator's manual, to operate and service the attachment safely and correctly.

If your attachment manual has a section called Preparing the Machine, it means that you will have to do something to your tractor or vehicle before you can install the attachment. The Assembly and Installation sections of this manual provide information to assemble and install the attachment to your tractor or vehicle. Use the Service section to make any needed adjustments and routine service to your attachment.

If you have any questions or concerns with the assembly, installation, or operation of this attachment, see your local John Deere dealer.

Warranty information on this John Deere attachment can be found in the warranty statement included in this manual.

---

---

## Product Identification

### Product Compatibility

This Sprayer is designed for use with John Deere riding lawn and garden products.

Contact your John Deere dealer for specific machine compatibility information.

*Original Instructions. All information, illustrations and specifications in this manual are based on the latest information available at the time of publication.*

*The right is reserved to make changes at any time without notice.*

# Safety Labels

## Safety Labels



### Understanding The Machine Safety Labels

The machine safety labels shown in this section are placed in important areas on your machine to draw attention to potential safety hazards.

On your machine safety labels, the words DANGER, WARNING, and CAUTION are used with this safety-alert symbol. DANGER identifies the most serious hazards.

The operator's manual also explains any potential safety hazards whenever necessary in special safety messages that are identified with the word, CAUTION, and the safety-alert symbol.

Replace missing or damaged safety labels. Use this operator's manual for correct safety label placement.

There can be more safety information contained on parts and components sourced from suppliers that is not reproduced in this operator's manual.

### French or Spanish Safety Labels and Operator's Manual

Operator's manuals and safety labels with content in French or Spanish are available for this machine through authorized John Deere dealers. See your John Deere dealer.

## Safety Labels

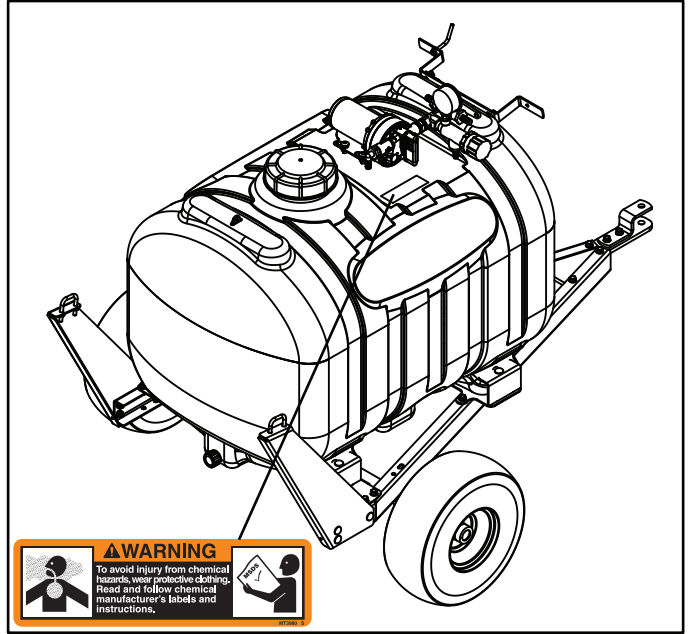

- To avoid injury from chemical hazards, wear protective clothing. Read and follow chemical manufacturer's labels and instructions.

# Safety

---

---

## Safety

### Read Safety in Machine Operator's Manual

Read the general safety operating precautions in your machine operator's manual for additional safety information.

### Operate Safely

- Read the machine and attachment operator's manual carefully. Be thoroughly familiar with the controls and the proper use of the equipment. Know how to stop the machine and disengage the controls quickly.
- Do not let children or an untrained person operate machine.
- Make any necessary adjustments before you operate. Never attempt to make any adjustments while the engine is running, unless if recommended in adjustment procedure.
- Take all possible precautions when leaving the machine unattended. Shut off the engine before making any repairs, adjustments, or inspections. Lower the attachment, lock the parking brake, stop the engine, and remove the key.
- Look behind machine before you back up. Back up carefully.
- Do not let anyone, especially children, ride on machine or attachment. Riders are subject to injury such as being struck by foreign objects and being thrown off. Riders may also obstruct the operator's view, resulting in the machine being operated in an unsafe manner.
- Use only attachments and accessories approved by the manufacturer of this product.
- If the machine vibrates abnormally, stop the engine and check immediately for the cause. Vibration is generally a warning of trouble.
- Always refer to the Storage section of the operator's manual for important details if storing this product for a long period of time.
- Keep people and pets out of the work area. Stop machine if anyone enters the area.
- If you hit an object, stop the machine and inspect it. Make repairs before you operate. Keep machine properly maintained and in good working order. Keep all shields and guards in place.
- Always inspect the sprayer completely before and after each use. Before pressurizing the system, check to be sure all fittings and hoses are tightly installed. Be sure guards and shields are in good condition and fastened in place. Make any necessary adjustments before you operate.
- Never use the sprayer during windy conditions.
- Always release pressure in the system before filling, cleaning or servicing the sprayer.
- Do not put nozzle tip or other sprayer parts to your lips to blow out dirt. Use compressed air.
- If the sprayer is mounted to the bed of a utility vehicle, never raise the bed with the sprayer installed. Empty the sprayer and remove it from the bed if you need to raise the bed for any reason.

### Parking Safely

1. Stop vehicle on a level surface, not on a slope.
2. Lock park brake.
3. Stop engine.
4. Remove key.
5. Before you leave the operator's seat, wait for engine and all moving parts to stop.

6. Disconnect the negative battery cable or remove the spark plug wire (for gasoline engines) before servicing the machine.

### Mix and Handle Chemicals Safely

- It is best to wear full cover clothing and always wear protective goggles and rubber gloves to protect yourself while handling chemicals.
- Follow instructions on chemical container labels.
- Open all chemical containers carefully, using proper tools.
- Open, pour, weigh and mix chemicals in a well-ventilated area.
- Reserve all equipment used for the application of chemicals exclusively for that purpose.
- Prohibit all smoking, drinking and eating food in chemical-handling area.
- It is a good practice to take a soapy shower immediately after the using the sprayer to apply chemicals.
- Wash all clothing worn when using chemicals separately in the laundry after spraying is completed.

### Read Chemical Container Label

- Chemicals can be dangerous. Improper selection or use can injure persons, animals, plants, soils or other property. Select the right chemical for the job and handle and apply with care.
- Read the instructions, precautions, and warnings on the container label before opening. Use the product strictly according to label directions for specific applications, in the amounts specified, at the times specified and only when needed.
- Keep the container closed tightly except when preparing the mix.
- Do not remove labels from chemical containers. Store all chemicals in their original containers.
- Do not mix chemicals unless stated on the container label.
- Store chemicals when not in use according to the container label.

### Handle Chemical Products Safely

- Direct exposure to hazardous chemicals can cause serious injury. Potentially hazardous chemicals used with John Deere equipment include pesticides, herbicides and fungicides.
- A Material Safety Data Sheet (MSDS) provides specific details on chemical products: physical and health hazards, safety procedures, and emergency response techniques.
- The MSDS should be obtained from the chemical dealer at the time of the chemical purchase.
- Check the MSDS before beginning any job using a hazardous chemical. Know exactly what the risks are and how to do the job safely. Always wear recommended personal protection equipment.

### Towing Loads Safely

- Stopping distance increases with speed and weight of towed load. Travel slowly and allow extra time and distance to stop.
- Total towed weight must not exceed limits specified in towing vehicle operator's manual.
- Excessive towed load can cause loss of traction and loss of control on slopes. Reduce towed weight when operating on slopes.
- Never allow children or others in or on towed equipment.
- Use only approved hitches. Tow only with a machine that has a hitch designed for towing. Do not attach towed equipment except at the approved hitch point.

# Safety

- Follow the manufacturer's recommendations for weight limits for towed equipment and towing on slopes. Use counterweights or wheel weights as described in the machine operator's manual.
- Do not turn sharply. Use additional caution when turning or operating under adverse surface conditions. Use care when reversing.
- Do not shift to neutral and coast downhill.

## Keep Riders Off Towed Attachment

- Keep riders off of a towed attachment.
- Riders on a towed attachment are subject to injury, such as being struck by objects and being thrown off the attachment during sudden starts, stops and turns.
- Riders obstruct the operator's view, resulting in the attachment being used in an unsafe manner.
- Keep riders off of hitch bracket.

## Avoid Injury From Drawbar

Before you disconnect an attachment from machine hitch plate:

- Unload attachment.
- Stop attachment on level ground.
- Stop machine engine.
- Lock machine park brake.
- Block attachment wheels.
- Make sure hands, feet or other body parts are not under drawbar.

## Practice Safe Maintenance

- Only qualified, trained adults should service this machine.
- Understand service procedure before doing work. Keep area clean and dry.
- Do not operate the engine in a confined space where dangerous carbon monoxide fumes can collect.
- Never lubricate, service or adjust the machine or attachment while it is moving. Keep safety devices in place and in working condition. Keep hardware tight.
- Keep hands, feet, clothing, jewelry, and long hair away from any moving parts, to prevent them from getting caught.
- Lower any attachment completely to the ground or to an existing attachment mechanical stop before servicing the attachment. Disengage all power and stop the engine. Lock park brake and remove the key. Let machine cool.
- Disconnect battery or remove spark plug wire (for gasoline engines) before making any repairs.
- Before servicing machine or attachment, carefully release pressure from any components with stored energy, such as hydraulic components and springs.
- Release hydraulic pressure by lowering attachment or cutting units to the ground or to a mechanical stop and move hydraulic control levers.
- Securely support any machine or attachment elements that must be raised for service work. Use jack stands or lock service latches to support components when needed.
- Never run engine unless park brake is locked.
- Keep all parts in good condition and properly installed. Fix damage immediately. Replace worn or broken parts. Replace all worn or damaged safety and instruction decals.

- Check all hardware at frequent intervals to be sure the equipment is in safe working condition.
- Do not modify machine or safety devices. Unauthorized modifications to the machine or attachment may impair its function and safety.

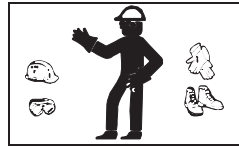

## Wear Appropriate Clothing

- Wear close fitting clothing and safety equipment appropriate for the job.
- Certain operating conditions may dictate that the operator and any passenger wear appropriate safety equipment while operating the vehicle. Be prepared for any existing and potential conditions before operating machine.
- Local safety or insurance regulations may require additional safety equipment such as eye protection or a hard hat.
- Always wear substantial footwear and long trousers. Do not operate the equipment when barefoot or wearing open sandals.
- Wear proper clothing and safety equipment while handling chemicals or using the sprayer. Refer to the MSDS for the chemicals being used to be sure the proper personal protection equipment is being used.



## Avoid High Pressure Fluids

- Hydraulic hoses and lines can fail due to physical damage, kinks, age, and exposure. Check hoses and lines regularly. Replace damaged hoses and lines.
- Hydraulic fluid connections can loosen due to physical damage and vibration. Check connections regularly. Tighten loose connections.
- Escaping fluid under pressure can penetrate the skin causing serious injury. Avoid the hazard by relieving pressure before disconnecting hydraulic or other lines. Tighten all connections before applying pressure.
- Search for leaks with a piece of cardboard. Protect hands and body from high pressure fluids.
- If an accident occurs, see a doctor immediately.

## Dispose of Chemicals Properly

- Proper disposal of excess spray material is very important. If you have excess tank solution, it is best to dilute it with water and apply it to the area you previously treated.
- Never dump solution into a drain or near a lake or stream.
- Chemicals containers should be triple-rinsed, with the rinse water added to the sprayer tank. Do not burn empty chemical containers. Dispose of containers at recycling centers.

## Handling Waste Product and Chemicals

Waste products, such as, used oil, fuel, coolant, brake fluid, and batteries, can harm the environment and people:

- Do not use beverage containers for waste fluids - someone may drink from them.
- See your local Recycling Center or authorized dealer to learn how to recycle or get rid of waste products.
- A Material Safety Data Sheet (MSDS) provides specific details on chemical products: physical and health hazards, safety procedures, and

# Assembly

emergency response techniques. The seller of the chemical products used with your machine is responsible for providing the MSDS for that product.

## Assembly

### Identify Parts

Shipped nearly assembled with small parts inside tank

Part Description	Quantity
Sprayer Assembly (attached to pallet)	1
Boom Assembly (optional)	1
Gauge	1
1/4" Bent Pin	1
1/4" Flange Nut	2
5/16" Square Bent U-bolt	2
5/16" Flange Nut	8
5/16" x 3/4" Carriage Bolt	4
Battery Harness	1
Switch Harness	1
Wire Clips	2

### Assembly

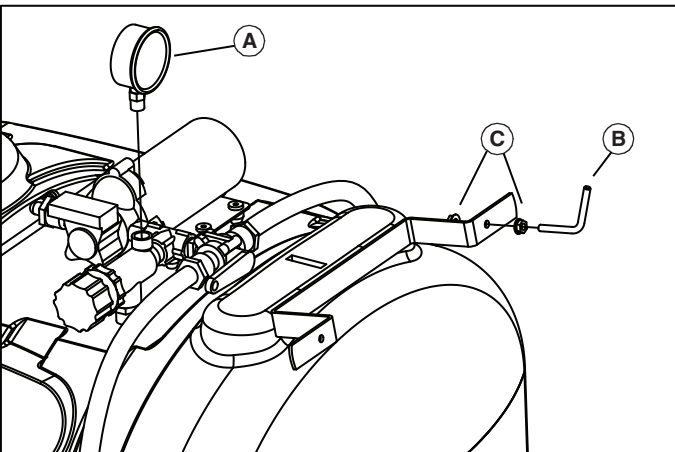

1. Screw gauge (A) into open port on relief valve.
2. Install 1/4" bent pin (B) into hose wrap bracket and tighten with two 1/4" flange nuts (C).
3. Wrap hose on bracket and hang handgun on 1/4" bent pin.

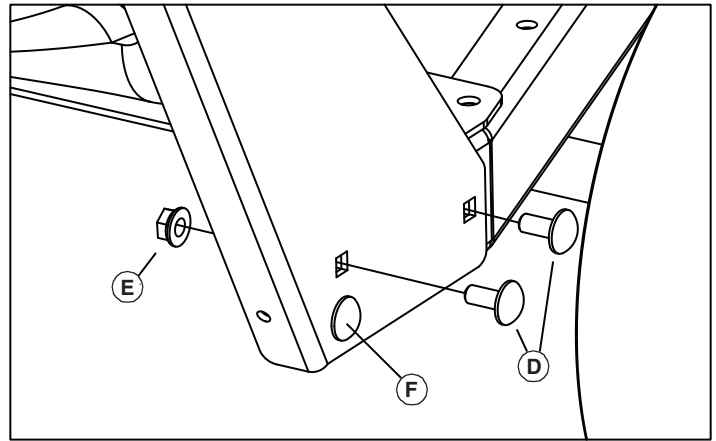

4. Rotate boom supports to line up holes in channel and fasten with two 5/16" x 3/4" carriage bolts (D) and 5/16" flange nuts (E). Also tighten nut on bolt (F).
5. Repeat step 4 on other side.

### Attach Boom

150" folding boom

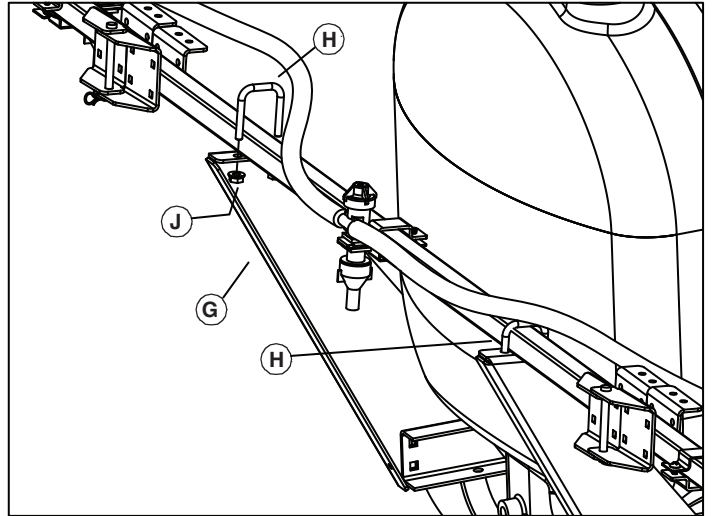

Boomless

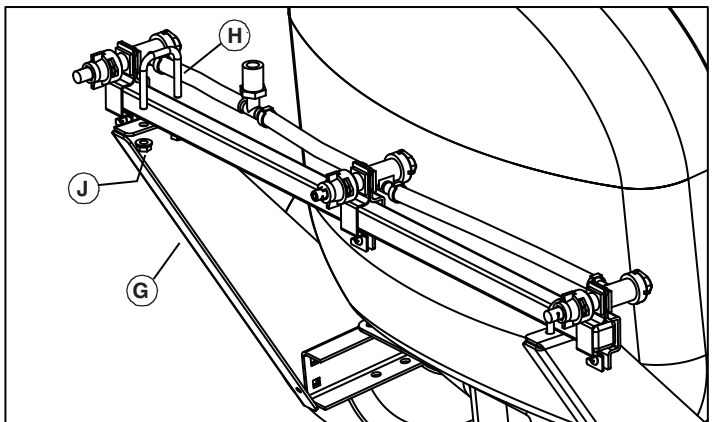

1. Place boom on top of boom support brackets (G) as shown. Center and fasten with two 5/16" U-bolts (H) and four 5/16" flange nuts (J). Connect plastic wing nut on sprayer to fitting on boom.

# Installing

## Install Wiring Harness (For Machines With Mid-Mounted Battery)

1. Open hood.

**NOTE:** Switch (A) is not located at center of main wiring harness. The harness plug connector nearest to the switch gets connected to the pump leads.

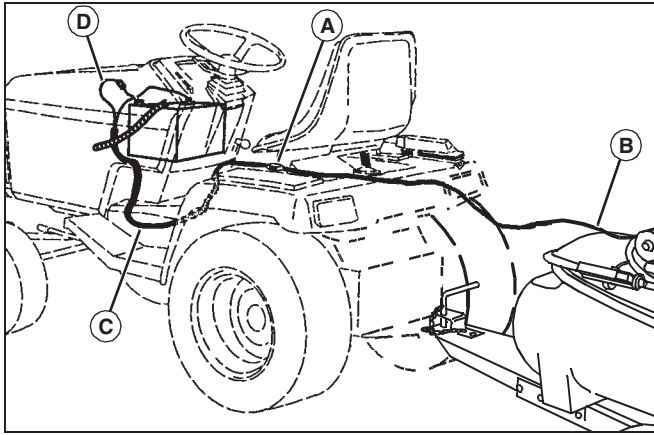

**Picture Note:** Wheeled Sprayer Shown

2. Connect main wiring harness to pump leads (B).

3. Route main harness as shown and clip in place at foot rest side panel (C). On some units route harness on right side of fuel tank filler neck.

**IMPORTANT:** Avoid damage! Avoid damage to wiring. Make sure hood does not close on wiring harnesses. Keep wiring harnesses away from all moving parts and hot surfaces.

4. Connect other end of main harness to fused battery lead (D).

5. Close hood.

## Install Wiring Harness (For Machines With Upper Front-Mounted Battery)

1. Open hood.

**NOTE:** Switch (A) is not located at center of main wiring harness. The harness wiring connector nearest to the switch gets connected to the pump leads.

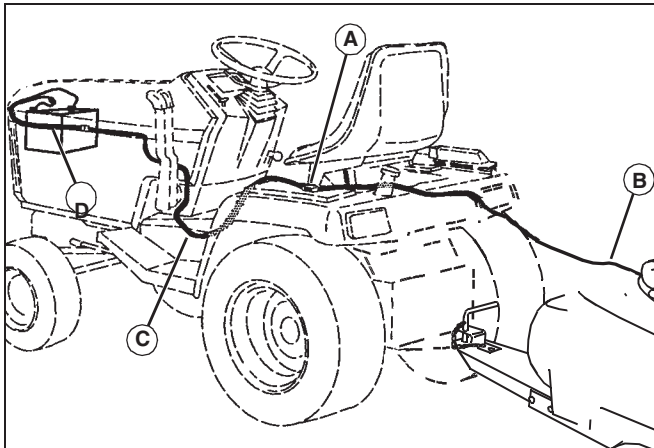

**Picture Note:** Wheeled Sprayer Shown

2. Connect main wiring harness to pump leads (B).

3. Route main harness as shown. Clip harness in place at foot rest side panel (C). On some units route harness on right side of fuel tank filler neck.

**IMPORTANT:** Avoid damage! Avoid damage to wiring. Make sure hood does not close on wiring harnesses. Keep wiring harnesses away from all moving parts and hot surfaces.

4. Make sure harness extension (D) passes between the left side hood rods. Connect the main harness to the wiring harness extension.

5. Close hood.

## Install Wiring Harness (For Machines With Lower Front-Mounted Battery)

1. Open hood.

**NOTE:** Switch (A) is not located at center of main wiring harness. The harness wiring connector nearest to the switch gets connected to the pump leads.

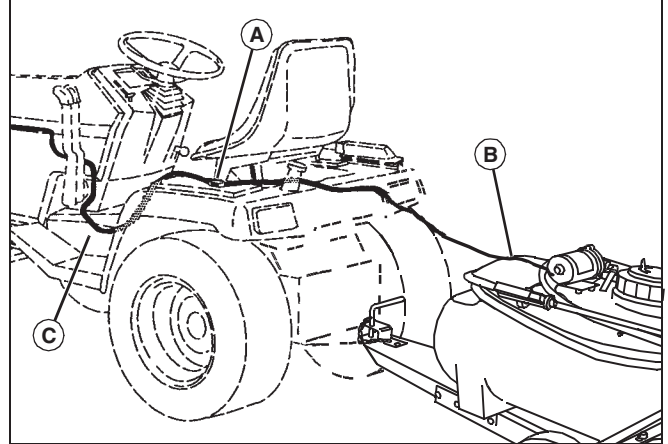

**Picture Note:** Wheeled Sprayer Shown

2. Connect main wiring harness (B) to pump leads.

3. Route main harness along fender as shown and clip in place at foot rest side panel (C).

**IMPORTANT:** Avoid damage! Avoid damage to wiring. Make sure hood does not close on wiring harnesses. Keep wiring harnesses away from all moving parts and hot surfaces.

4. For most machines, route main harness along the top of side panel, and connect main harness plug to harness extension.

5. Close hood.

## Install Wire Clips

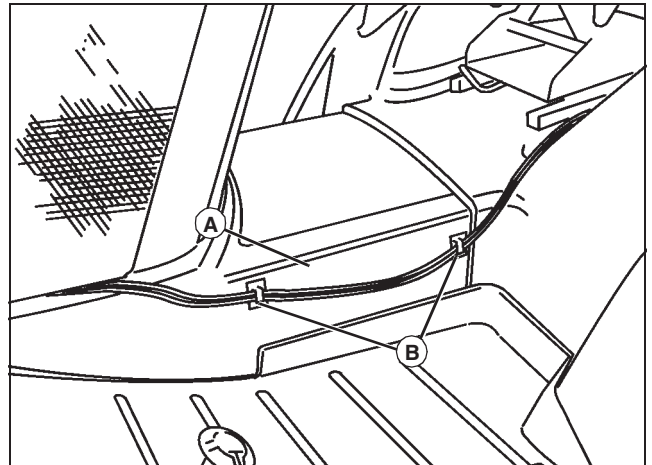

1. Clean foot rest side panel (A) at left side of machine with mild detergent or isopropyl alcohol. Dry thoroughly.

2. Attach wire clips (B) to panel. Position the clips as shown so that sprayer main wiring harness will not interfere with deck height adjustment crank, if equipped.

# Preparing Vehicle

## Preparing Vehicle

### Machine Requirements

#### Sprayer Weight:

- 60 Gallon Sprayer, Filled with liquid is 281 kg (620 lb)

**IMPORTANT: Avoid damage! No rear suitcase weights or grass bagging attachments should be installed on machine while using sprayers.**

Make sure machine tire pressure is correct. (See your machine operator's manual for the correct pressure.)

Machine weights improve stability. Add front weights for better front-end stability and steering. See your John Deere dealer for these weights. Instructions to install will come with the weights.

Your machine requires the following:

- 12-Volt Battery and Alternator
- Wiring Harness Extension: This part is required for all machines with the battery mounted near the front grille. Order this wiring harness from your John Deere dealer.
- Utility Vehicles require an additional 12 V adapter. Order this adapter from your John Deere dealer.

## Removing and Storing

### Removing Sprayer

1. Park machine safely. (See Parking Safely in the Safety section.)
2. Empty the sprayer tank.
3. Disconnect the main wiring harness only. Leave all other harnesses installed on machine.
4. Roll up the main harness and store with sprayer.
5. Remove Sprayer:
  - a. Fold in boom extensions (150" folding boom only)
  - b. Pull spring locking pin (B) out of hitch pin (C). Remove hitch pin (C).
  - c. Pull sprayer back from machine.
  - d. Put hitch pin in sprayer hitch for storage.

### Store Sprayer Safely

1. Clean and drain sprayer tank.
2. For 150" folding boom, fold in boom extensions.
3. Remove sprayer from transport vehicle.
4. Check sprayer for worn or damaged parts. Replace parts as needed.
5. Tighten loose hardware.

## Operating

### Filling Sprayer Tank



**CAUTION: Avoid injury! Chemicals can be dangerous. Avoid injury to operator or bystanders:**

- Read chemical container label for mixing and handling instructions. A Material Safety Data Sheet (MSDS) should be supplied by the chemical dealer and provides proper safety information.
- Wear proper clothing and safety equipment while handling or applying spray chemicals.
- Wear a full covering of clothing, protective goggles and rubber gloves.
- Prohibit all smoking, drinking, and eating around chemicals.
- When filling tank, never allow end of water hose to contact chemical mixture.

1. Clean area around tank filler cap to prevent tank contamination.
2. Remove tank filler cap and fill tank.

### Draining and Cleaning Sprayer Tank

**IMPORTANT: Avoid damage!**

- Proper disposal of excess spray is very important. Dilute it with water and apply it to area previously treated.
- Never dump excess into a storm drain or near a lake or stream.

1. Remove tank drain cap, and empty sprayer tank:
  - Empty remaining solution into an appropriated container for proper disposal.
2. Spray all inside surfaces of tank with low pressure garden hose to remove any remaining solution. Rinse several times to make sure sprayer tank is clean and free of chemicals.
3. Replace drain cap and run fresh, clean water through pump, sprayer wand and all hoses thoroughly.
4. Once the tank is empty, wipe out inside of sprayer tank with a clean cloth or paper towel.

### Transporting Wheeled Sprayer Safely

- Push pump switch to off position.
- Fold boom extensions in their transport position.

#### Sprayer Weight:

- 60 Gallon Sprayer - Filled with liquid is 281 kg (620 lb)

### Spraying Tips

- Do not let sprayer run in one spot.
- Do not over spray when you use weed killers.
- Liquid spray material is recommended. Sprayer does not agitate wettable powders.
- Timely applications of a smaller dosage are better than large applications.
- Turn sprayer off during turns to avoid double spraying.
- Fill sprayer where spills cannot harm grass.
- Follow manufacturer's recommendations for application of specific chemicals.
- Stop sprayer when tank is empty.



# Operating

## Starting and Stopping Sprayer

**IMPORTANT: Avoid damage! Operate sprayer with transport vehicle running to avoid discharging the battery.**

**NOTE: The sprayer pump to battery hookup is a direct electrical connection. Shutting off the transport vehicle does not prevent operation of the sprayer pump. To avoid accidental spraying, disconnect the pump connection before leaving the sprayer.**

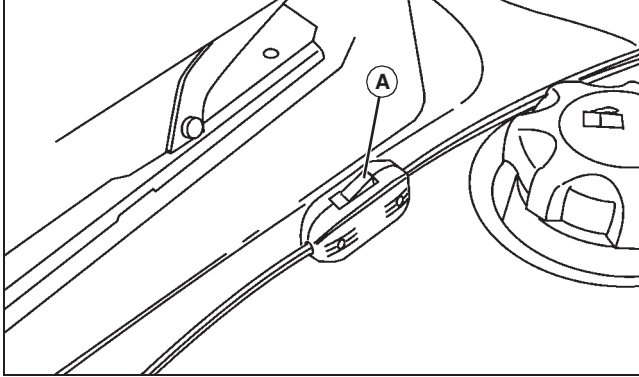

Push switch (A) to on or off position to start or stop sprayer.

## Sprayer Controls

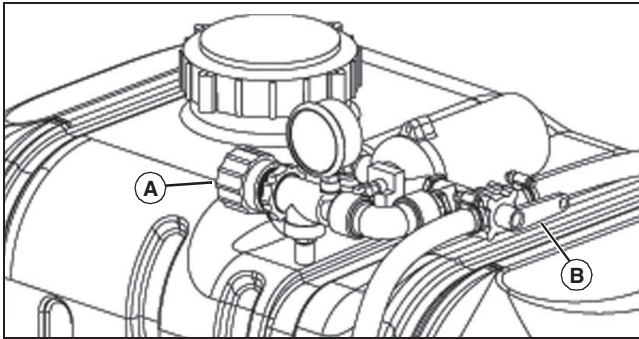

Turn knob (A) clockwise to control pressure and recirculation.

Turn knob (A) counter clockwise to recirculate more material to tank and adjust pressure to boom or wand.

Use valve (B) to route spray to spray gun or boom. The direction the handle is pointing, is the direction of flow.

## Using Spray Gun

1. Turn selector lever to spray gun position.

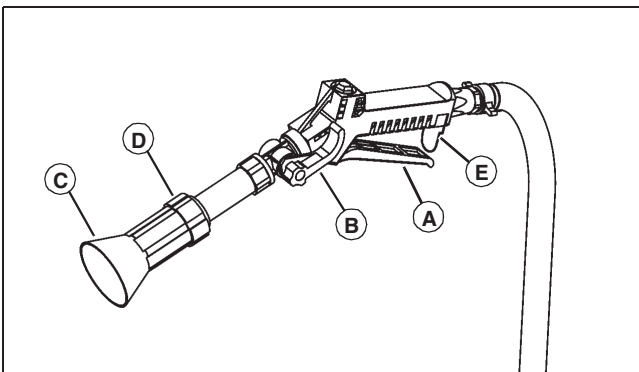

2. Squeeze handle (A) to spray.

3. Adjust mist to stream using lever (B).

4. Spray guard (C) can be adjusted by loosening (D) and sliding spray guard to desired position. Spray guard is intended to keep overspray off hands.

5. Flip handle lock (E) forward to lock handle in ON position.

## Calibrating the Sprayer

1. Drive vehicle and sprayer (half-full is optimal) across a measured distance at a constant speed. There can be no change in speed while measuring time. Speed should be a comfortable speed for spraying.

2. Have someone measure the amount of time (in seconds) it takes to travel the measured distance.

3. Speed can be found by entering data into the equation: speed (mph) = distance (ft) x 60/time (sec) x 88, or by consulting the following table. It is helpful to note throttle location, gear and/or RPMs in order to maintain accuracy.

Speed in mph	Time (sec) required to travel a distance of:	
	200 ft	300 ft
1	136	205
1.5	91	136
2	68	102
2.5	55	82
3	45	68
3.5	39	58
4	34	51
4.5	30	45
5	27	41
5.5	25	37
6	23	34
6.5	21	31
7	19	29

# Operating

## Using Calibration Chart

The spray nozzles on your sprayer are AIC11004, which matches up with the calibration chart. Look at the calibration chart. Use your vehicle speed and desired gallons per acre (gpa), find the pressure (psi) necessary to achieve your gpa. It is important to note that lower pressure settings will result in less spray drift.

Example:

Assume you have found your vehicle speed to be 4 mph, your nozzles are red AIC11004, and you want to spray 20 gpa. By looking at the chart, you find that you should set the sprayer pressure at 40 psi in order to apply 20 gpa.

**NOTE: Optimum spray performance is achieved over 30 psi. When shutting off tips use the regulator valve to adjust your boom pressure accordingly.**

## Adjusting Pressure on Sprayer

**NOTE: All calibration needs to be done with clean water.**

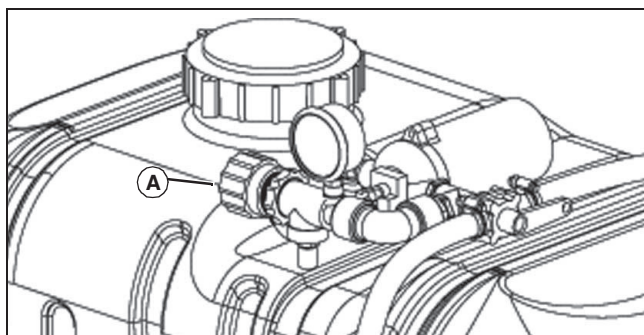

## Sprayer Pressure Setting:

You have found the correct pressure setting, but must now adjust sprayer to that pressure setting. The relief valve (A) controls the sprayers pressure and is located directly beside the pressure gauge. When ready to spray, turn relief valve until necessary pressure is achieved. Sprayer is now calibrated.

## 150" Folding Boom

150" FOLDING BOOM CALIBRATION CHART						
Tip Size	PSI	GPM one nozzle	GPA 30 inch spacing			
			4 mph	5 mph	6 mph	8 mph
AIC11004	30	0.35	17.3	14	11.5	8.7
	40	0.40	20	16	13.2	9.9
	50	0.45	22	18	14.7	11.1
	60	0.49	24	19.3	16	12.1

## Boomless Nozzles

BOOMLESS CALIBRATION CHART						
PSI	Cap 3 Nozzle GPM	Spray Width (ft)	GPA			
			4 mph	6 mph	8 mph	10 mph
20	3.65	23	12	8	6.1	4.9
30	4.19	25	12.9	8.6	6.5	5.2
40	4.8	28	13.7	9.1	6.8	5.5

## Useful Formulas

GPA	=	gallons per acre
GPM	=	gallons per minute
MPH	=	miles per hour
GAL/1000ft <sup>2</sup>	=	gallons per 1000 sq. ft.
W	=	nozzle spacing in inches
GPM/per nozzle	=	gpa x mph x w / 5940
GPM/per nozzle	=	gal/1000ft <sup>2</sup> x mph x w / 136
GPA	=	5940 x gpm (per nozzle) / mph x w
GPA	=	gallons per 1000 sq. ft. / .023
GAL/1000ft <sup>2</sup>	=	136 x gpm (per nozzle) / mph x w

## RATES OF FLOW (Calibration of Spray Tips)

GPM	Seconds to collect 1 qt.	GPM	Seconds to collect 1 qt.
0.05	300	0.20	75
0.06	250	0.23	67
0.07	214	0.25	60
0.08	188	0.30	50
0.09	167	0.35	40
0.10	150	0.40	35
0.11	136	0.50	30
0.12	125	0.60	25
0.13	115	0.70	20
0.14	107	0.80	15
0.15	100	0.90	17
0.17	80	1.00	15

**NOTICE:** Avoid contamination when switching from one chemical to another chemical in the sprayer where contamination must be prevented. Wash with tank cleaner and water throughout the tank, pump, and all hoses. Flush with water two to three times. Herbicides such as 2-4D are hard to remove. Follow instructions on procedures noted on all labels.

## Transporting Sprayer Safely

- Use caution when transporting the sprayer to help prevent possible injury.
- Push pump switch to OFF position.
- When sprayer is filled with liquid, the extra weight on the back of a machine could change the stability of the machine.

# Service

## Service

### Checking Tire Pressure

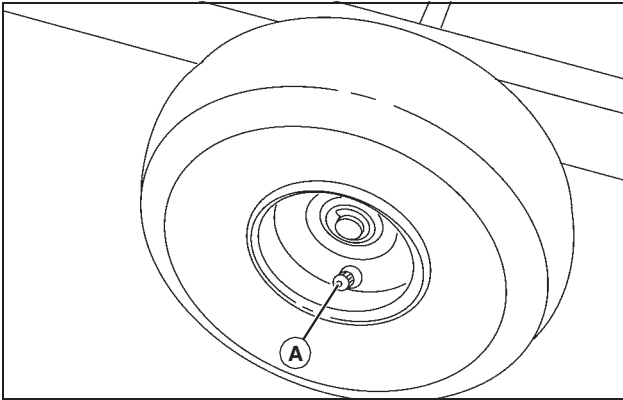

Check tire pressure at point (A).

- Tire pressure should be 207 kPa (30 psi).
- Tire Size - 15 x 6.00 - 6

### Cleaning Spray Nozzle

**CAUTION: Avoid injury! Do not put nozzle tip or other sprayer parts to your lips to blow out dirt. Use compressed air or clean water.**

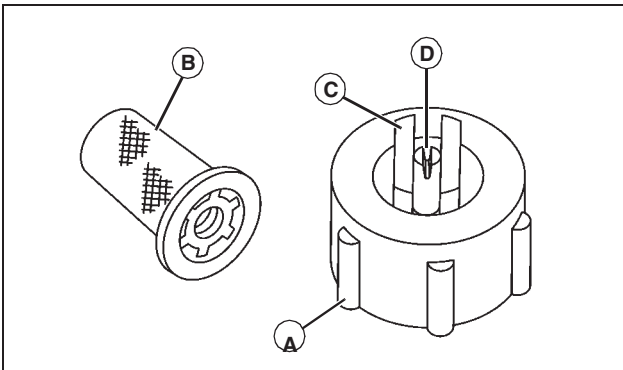

1. Remove spray nozzle (A) from sprayer.
2. Disassemble filter (B) and spray tip (C).

**NOTE: Do not use a wire to clean opening (D) in spray tip.**

3. Wash filter and spray tip in a non-flammable solvent.
4. Put spray tip in spray nozzle.
5. Put flat side of filter in spray nozzle.
6. Install assembly on sprayer and tighten nozzle.

### Cleaning Spray Wand Nozzle

**NOTE: There are two different styles of nozzles for your sprayer. See below for explanation of each style.**

**CAUTION: Avoid injury! Do not put nozzle tip or other sprayer parts to your lips to blow out dirt. Use compressed air or clean water.**

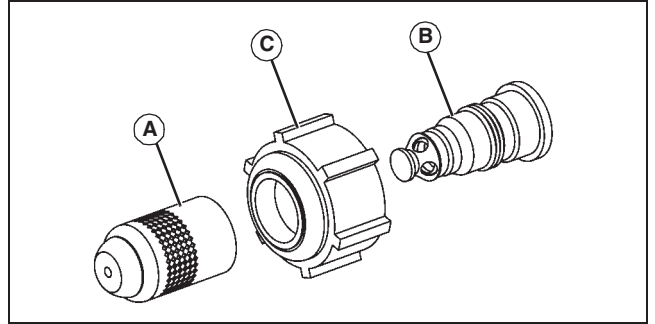

1. Remove nozzle (A) from the spray tip (B).
2. Loosen nut (C), and remove the spray tip (B) from the angled fitting on the wand.
3. Wash nozzle (A), and spray tip (B) with liquid detergent and warm water.
4. Inspect O-rings and replace as needed.
5. Slide nut (C) over the spray tip (B), and install on angled fitting on wand.
6. Install nozzle (A) on spray tip (B).

### Cleaning Pump Suction Screen

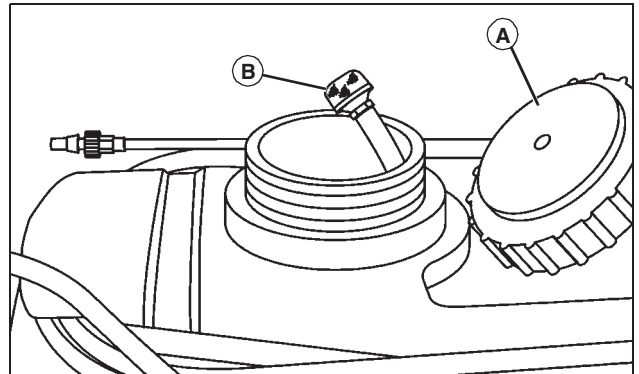

1. Remove tank cover (A).
2. Locate suction screen (B) inside sprayer tank.
3. If necessary, unscrew suction screen and clean with liquid detergent and warm water.
4. If suction screen was removed, install on suction hose and position in lowest depression inside tank.
5. Install and tighten tank cover.

### Changing Fuse

**IMPORTANT: Avoid damage! The electrical system may be damaged if incorrect replacement fuses are used. Replace the bad fuse with a fuse of the same amp rating.**

1. Open hood.

# Troubleshooting

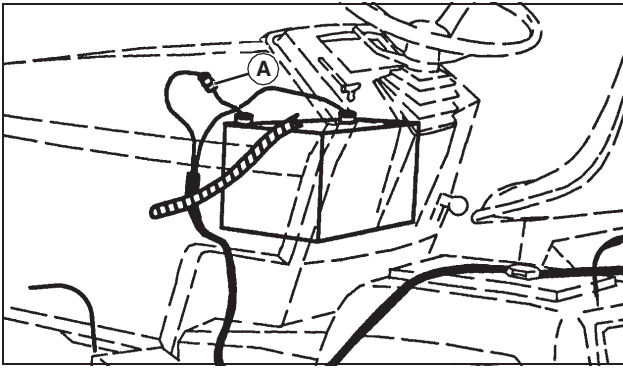

M61159

2. Remove fuse (A).
3. Install new 15 amp fuse.
4. Close hood.

## Troubleshooting

### Using Troubleshooting Chart

If you are experiencing a problem that is not listed in this chart, see your authorized dealer for service.

When you have checked all the possible causes listed and you are still experiencing the problem, see your authorized dealer.

### Using Troubleshooting Chart

IF	CHECK
Pump Loses Suction.	Clean Pump suction screen. Check tank fill level. Fill tank. Clean or replace pump. Check for loose pump fittings.
Pump Capacity Decreased.	Clean pump suction screen. Clean spray nozzle(s). Selection lever is not completely turned on, or is in the OFF position.
Poor Spray Pattern.	Clean spray nozzles. Adjust nozzle height. Align spray tips with boom.
Pump Does Not Work.	Check wiring connections. Check machine battery. Clean debris from pump. Check pump switch. Check pump motor. Check fuse at battery. Adjust pump.

## Specifications

Tank	227 L (60 gallon)
<b>Pump:</b>	
Type	Electric Motor and Diaphragm
Current Draw	7 amp
Fuse	15 amp
System Pressure	689 kPa (100 psi)
Spray Rate	15.1 L/min. (4.0 gal/min.)
Suction Hose Strainer	Stainless Steel
Spray Tip Material	Plastic
<b>Sprayer Wand:</b>	
Material	Plastic, Metal Alloy, Brass
Adjustment	Single Hand Fan To Stream
<b>Sprayer:</b>	
Precision Swath	381 cm (150 in.)
Boomless Swath	914 cm (360 in.)
<b>Weight:</b>	
Empty	54 kg (120 lb)
Full	281 kg (620 lb)

## Getting Quality Service

### John Deere Quality Continues with Quality Service

John Deere provides a process to handle your questions or problems, should they arise, to ensure that product quality continues with quality parts and service support.

Follow the steps below to get answers to any questions you may have about your product.

1. Refer to your attachment and machine operator manuals.
2. In North America or Canada, call Agri-Fab Customer Service at 1-800-448-9282 and provide product serial number (if available) and model number.

# Warranty

---

---

## Warranty

### Limited Warranty for New John Deere Licensed Products

Agri-Fab's sprayers are guaranteed to be free from defects in material and workmanship from the date of purchase for 2 years residential use, 6 months commercial use, provided that the purchaser properly assembles, installs, uses and maintains the products in accordance with this manual. Purchaser's failure to adhere to such requirements will void the warranty. To the extent permitted by applicable law, all other warranties, representations, obligations and conditions, expressed or implied, including but not limited to implied warranties of merchantability, fitness for any particular purpose and non-infringement, are hereby disclaimed and excluded. Any product which does not meet warranty shall, as purchaser's sole and exclusive remedy, be repaired or replaced by Agri-Fab. This warranty is non transferrable. In addition, our warranty does not cover:

- Labor charges;
- Loss or consequential, incidental or special damages of any kind; and
- Breakage of parts as a result of freezing - *fittings, hand wands and pumps may crack if liquid is left inside at freezing temperatures.*





