



JOHN DEERE

Product Services Information

INSTALLATION INSTRUCTIONS

(English)



JOHN DEERE

REMOTE CONTROL

Compatibility

Compatible with all John Deere electric sprayers not exceeding 12VDC and 15 amps.

Parts in Kit

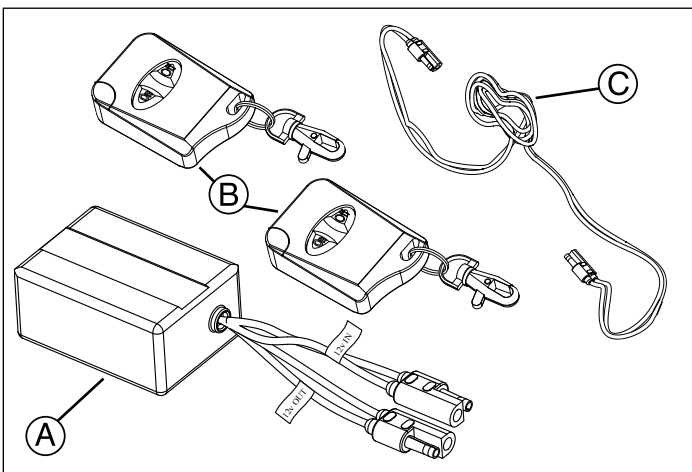

Qty.	Description
1	Remote Receiver Box (A)
2	Control FOBs (B)
1	8 ft. Wire Harness Extension (C)
1	Adhesive Backing (Attached to Receiver)

Parking Safely

1. Stop machine on a level surface, not on a slope.
2. Disengage mower blades or any other attachments.
3. Lower attachments to the ground.
4. Lock the park brake.
5. Stop the engine.
6. Remove the key.
7. Wait for engine and all moving parts to stop before you leave the operator's seat.
8. Close fuel shut-off valve, if your machine is equipped.
9. Disconnect the negative battery cable or remove the spark plug wire (for gasoline engines) before servicing the machine.

NOTE: Be sure to note your receiver/FOB frequency located on the back of the remote receiver box and each FOB. Write in this manual in the space provided to assist in ordering additional FOBs or replacement parts.

Frequency Code:

NOTE: When making wire connections make sure you match polarity (red wire connects to red wire, black wire to black wire).

Installing Remote Control/Receiver Box

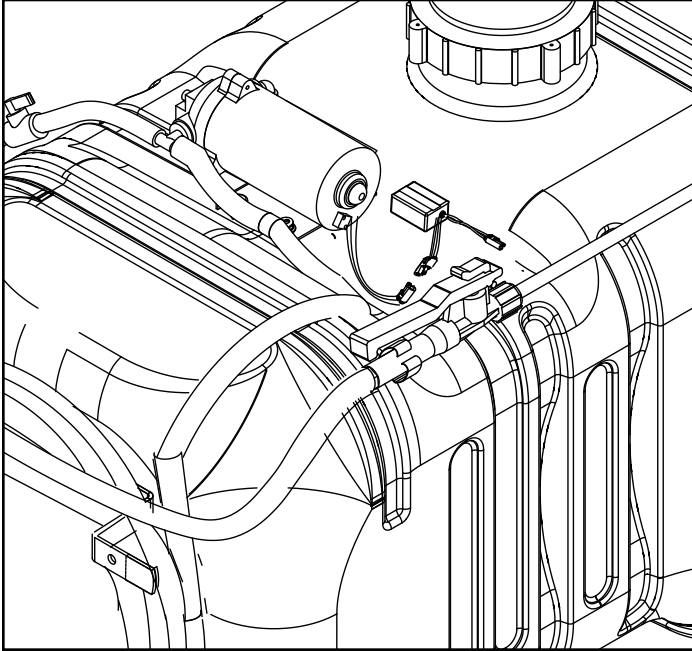

1. Plug the wires labeled “12v Out” into the pump or motor side of your sprayer.

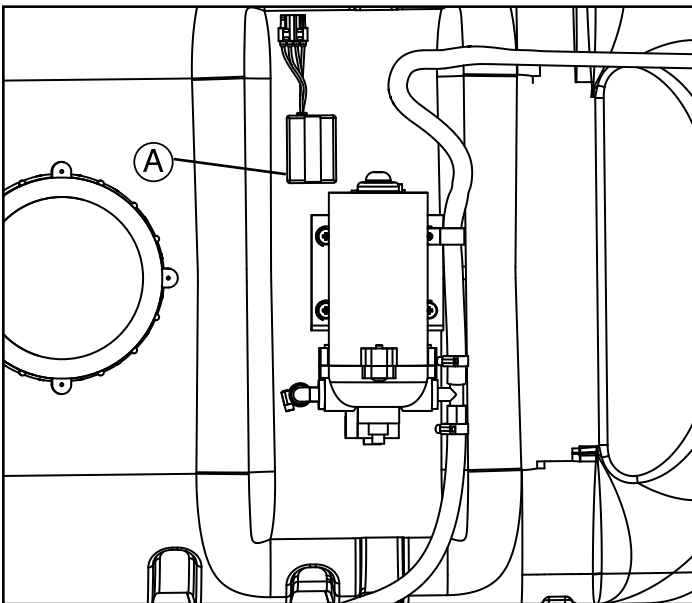

Figure 1 - 40 and 45 gal tank installation

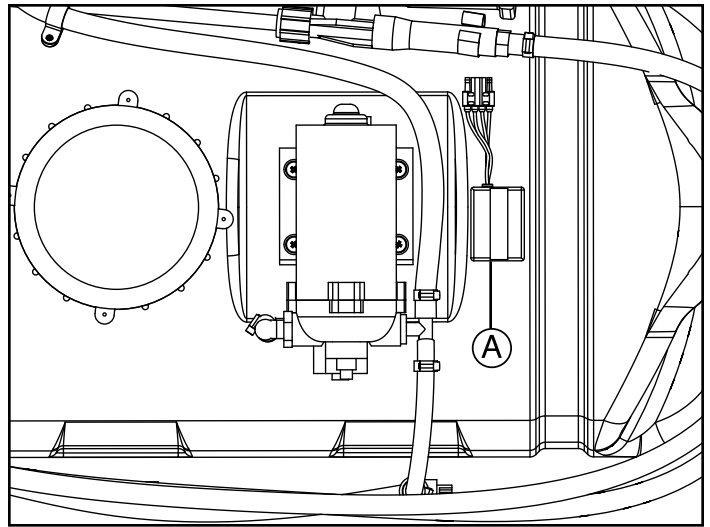
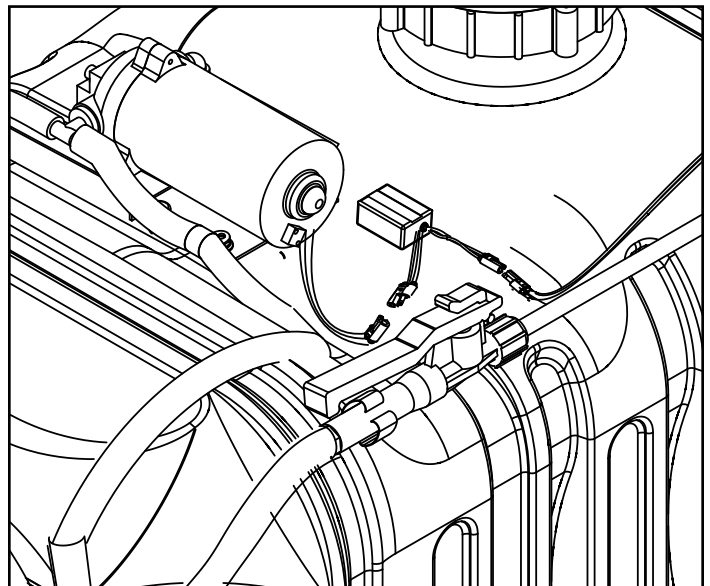

Figure 2 - 15 and 25 gal tank installation

2. Expose adhesive backing located on the back of the remote receiver box and adhere the receiver box (A) close to the electric motor but out of the way of hoses, cap or moving parts.

NOTE: Be sure surface is clean and dry prior to adhering to sprayer. It is recommended to wipe area thoroughly with alcohol or a non-residue cleaning agent.



3. Install the 8 ft. wire harness in place of your switched harness following the same route. In the event you choose to continue to use the switched harness, make sure the switch is in the “on” position.



CAUTION: Avoid damage! Avoid damage to wiring. Make sure hood does not close on wiring harness. Keep wiring harnesses away from all moving parts and hot surfaces.

Specifications

Max Amp..... 15 amp
 Required Batteries
 Remote..... 27A - 12v
 Maximum Range..... 100 ft. unobstructed*

4. Connect the wire extension/switch harness to the fused battery lead or fused 12v plug in adaptor supplied with your sprayer.

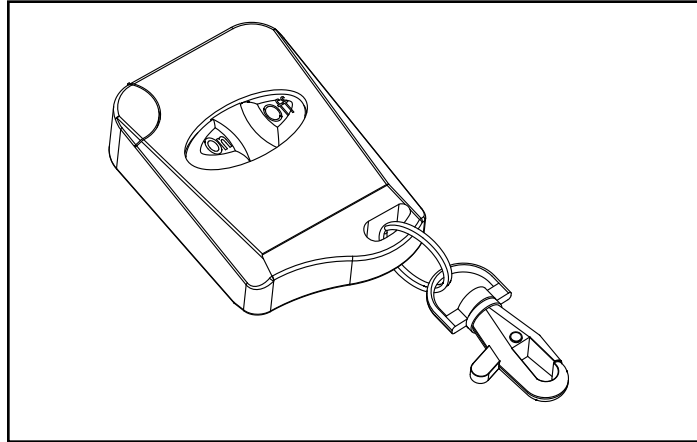

5. Attach FOB to key chain using the attached clamp.

NOTE: the receiver box is epoxy sealed for weather resistance. It is recommended that you wipe off the receiver after spraying to help protect the integrity of the sealer. The remote FOB is NOT waterproof.

Operation

- Once installed, press the ON or OFF buttons on the remote FOB to control the power of your sprayer.
- The 12v Remote Control Kit simplifies wire routing and facilitates spraying convenience. It works from up to 100 feet from the sprayer.

Transmitter Compliance Statement:

This device complies with Part 15 of FCC Rules.

Operation is subject to the following two conditions:

- (1) this device may not cause harmful interference, and
- (2) this device must accept any interference received, including interference that may cause undesired operation.

Transmitters comply with all United States and Canadian legal requirements as of the date of manufacture. No warranty is made that they comply with all legal requirements of any other jurisdiction. If transmitters are to be used in another country, the importer must determine compliance with any local laws and regulations which may differ from United States and Canadian requirements prior to use.

Warning: Do not deploy this item for emergencies involving fire, security and safety of life.