

JOHN DEERE
AG & TURF DIVISION

Tractor Mounted Sprayer
25 Gallon
04/2622
OMM162533 K1
OPERATOR'S MANUAL



JOHN DEERE

Original Instruction
All information, illustrations and specifications in this manual are based on the latest information at the time of publication. The right is reserved to make changes at any time without notice.

COPYRIGHT© 2012

Deere & Co.

John Deere Ag & Turf Division

All rights reserved

Previous Editions

COPYRIGHT© 2010

North American Version

Litho in U.S.A.



SELF



OMM162533

Introduction

Introduction

Using Your Operator's Manual

Read this entire operator's manual, especially the safety information, before operating.

This manual is an important part of your machine. Keep all manuals in a convenient location so they can be accessed easily.

Use the safety and operating information in the attachment operator's manual, along with the machine operator's manual, to operate and service the attachment safely and correctly.

If your attachment manual has a section called Preparing the Machine, it means that you will have to do something to your tractor or vehicle before you can install the attachment. The Assembly and Installation sections of this manual provide information to assemble and install the attachment to your tractor or vehicle. Use the Service section to make any needed adjustments and routine service to your attachment.

If you have any questions or concerns with the assembly, installation, or operation of this attachment, see your local John Deere dealer or call the John Deere Customer Contact Center at 1-800-448-9282 for assistance.

Warranty information on this John Deere attachment can be found in the warranty that came with your John Deere tractor or vehicle.

Product Identification

Product Compatibility

The 25 Gallon Sprayer is designed for use with John Deere Riding Lawn Tractors.

Contact your John Deere dealer for specific tractor compatibility information.

Safety Labels

Safety Labels



Understanding The Machine Safety Labels

The machine safety labels shown in this section are placed in important areas on your machine to draw attention to potential safety hazards.

On your machine safety labels, the words DANGER, WARNING, and CAUTION are used with this safety-alert symbol. DANGER identifies the most serious hazards.

The operator's manual also explains any potential safety hazards whenever necessary in special safety messages that are identified with the word, CAUTION, and the safety-alert symbol.

Safety Labels

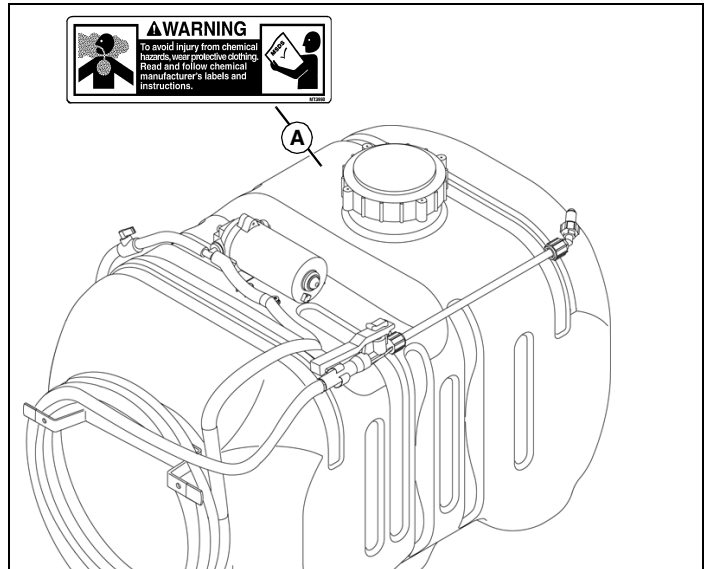

MX27819

A- Warning MT3980

WARNING MT3980



MT3980

- To avoid injury from chemical hazards, wear protective clothing. Read and follow chemical manufacturer's labels and instructions.

Safety

Safety

Read Safety in Machine Operator's Manual

Read the general safety operating precautions in your machine operator's manual for additional safety information.

Operate Safely

- Read the machine and attachment operator's manual carefully. Be thoroughly familiar with the controls and the proper use of the equipment. Know how to stop the machine and disengage the controls quickly.
- Do not let children or an untrained person operate machine.
- Make any necessary adjustments before you operate. Never attempt to make any adjustments while the engine is running, unless if recommended in adjustment procedure.
- Take all possible precautions when leaving the machine unattended. Shut off the engine before making any repairs, adjustments, or inspections. Lower the attachment, lock the parking brake, stop the engine, and remove the key.
- Look behind machine before you back up. Back up carefully.
- Do not let anyone, especially children, ride on machine or attachment. Riders are subject to injury such as being struck by foreign objects and being thrown off. Riders may also obstruct the operator's view, resulting in the machine being operated in an unsafe manner.
- Use only attachments and accessories approved by the manufacturer of this product.
- If the machine vibrates abnormally, stop the engine and check immediately for the cause. Vibration is generally a warning of trouble.
- Always refer to the Storage section of the operator's manual for important details if storing this product for a long period of time.
- Keep people and pets out of the work area. Stop machine if anyone enters the area.
- If you hit an object, stop the machine and inspect it. Make repairs before you operate. Keep machine properly maintained and in good working order. Keep all shields and guards in place.
- Always inspect the sprayer completely before and after each use. Before pressurizing the system, check to be sure all fittings and hoses are tightly installed. Be sure guards and shields are in good condition and fastened in place. Make any necessary adjustments before you operate.
- Never use the sprayer during windy conditions.
- Always release pressure in the system before filling, cleaning or servicing the sprayer.
- Do not put nozzle tip or other sprayer parts to your lips to blow out dirt. Use compressed air.
- If the sprayer is mounted to the bed of a utility vehicle, never raise the bed with the sprayer installed. Empty the sprayer and remove it from the bed if you need to raise the bed for any reason.

Parking Safely

1. Stop vehicle on a level surface, not on a slope.
2. Lock park brake.
3. Stop engine.
4. Remove key.
5. Before you leave the operator's seat, wait for engine and all moving parts to stop.

6. Disconnect the negative battery cable or remove the spark plug wires (for gasoline engines) before servicing the machine.

Mix and Handle Chemicals Safely

- It is best to wear full cover clothing and always wear protective goggles and rubber gloves to protect yourself while handling chemicals.
- Follow instructions on chemical container labels.
- Open all chemical containers carefully, using proper tools.
- Open, pour, weigh and mix chemicals in a well-ventilated area.
- Reserve all equipment used for the application of chemicals exclusively for that purpose.
- Prohibit all smoking, drinking and eating food in chemical-handling area.
- It is a good practice to take a soapy shower immediately after the using the sprayer to apply chemicals.
- Wash all clothing worn when using chemicals separately in the laundry after spraying is completed.

Read Chemical Container Label

- Chemicals can be dangerous. Improper selection or use can injure persons, animals, plants, soils or other property. Select the right chemical for the job and handle and apply with care.
- Read the instructions, precautions, and warnings on the container label before opening. Use the product strictly according to label directions for specific applications, in the amounts specified, at the times specified and only when needed.
- Keep the container closed tightly except when preparing the mix.
- Do not remove labels from chemical containers. Store all chemicals in their original containers.
- Do not mix chemicals unless stated on the container label.
- Store chemicals when not in use according to the container label.

Handle Chemical Products Safely

- Direct exposure to hazardous chemicals can cause serious injury. Potentially hazardous chemicals used with John Deere equipment include pesticides, herbicides and fungicides.
- A Material Safety Data Sheet (MSDS) provides specific details on chemical products: physical and health hazards, safety procedures, and emergency response techniques.
- The MSDS should be obtained from the chemical dealer at the time of the chemical purchase.
- Check the MSDS before beginning any job using a hazardous chemical. Know exactly what the risks are and how to do the job safely. Always wear recommended personal protection equipment.

Practice Safe Maintenance

- Only qualified, trained adults should service this machine.
- Understand service procedure before doing work. Keep area clean and dry.
- Do not operate the engine in a confined space where dangerous carbon monoxide fumes can collect.
- Never lubricate, service or adjust the machine or attachment while it is moving. Keep safety devices in place and in working condition. Keep hardware tight.
- Keep hands, feet, clothing, jewelry, and long hair away from any moving parts, to prevent them from getting caught.

Assembly

- Lower any attachment completely to the ground or to an existing attachment mechanical stop before servicing the attachment. Disengage all power and stop the engine. Lock park brake and remove the key. Let machine cool.
- Disconnect battery or remove spark plug wire (for gasoline engines) before making any repairs.
- Before servicing machine or attachment, carefully release pressure from any components with stored energy, such as hydraulic components and springs.
- Release hydraulic pressure by lowering attachment or cutting units to the ground or to a mechanical stop and move hydraulic control levers.
- Securely support any machine or attachment elements that must be raised for service work. Use jack stands or lock service latches to support components when needed.
- Never run engine unless park brake is locked.
- Keep all parts in good condition and properly installed. Fix damage immediately. Replace worn or broken parts. Replace all worn or damaged safety and instruction decals.
- Check all hardware at frequent intervals to be sure the equipment is in safe working condition.
- Do not modify machine or safety devices. Unauthorized modifications to the machine or attachment may impair its function and safety.

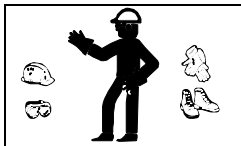

Wear Appropriate Clothing

- Wear close fitting clothing and safety equipment appropriate for the job.
- Certain operating conditions may dictate that the operator and any passenger wear appropriate safety equipment while operating the vehicle. Be prepared for any existing and potential conditions before operating machine.
- Local safety or insurance regulations may require additional safety equipment such as eye protection or a hard hat.
- Always wear substantial footwear and long trousers. Do not operate the equipment when barefoot or wearing open sandals.
- Wear proper clothing and safety equipment while handling chemicals or using the sprayer. Refer to the MSDS for the chemicals being used to be sure the proper personal protection equipment is being used.



Avoid High Pressure Fluids

- Hydraulic hoses and lines can fail due to physical damage, kinks, age, and exposure. Check hoses and lines regularly. Replace damaged hoses and lines.
- Hydraulic fluid connections can loosen due to physical damage and vibration. Check connections regularly. Tighten loose connections.
- Escaping fluid under pressure can penetrate the skin causing serious injury. Avoid the hazard by relieving pressure before disconnecting hydraulic or other lines. Tighten all connections before applying pressure.
- Search for leaks with a piece of cardboard. Protect hands and body from high pressure fluids.
- If an accident occurs, see a doctor immediately. Any fluid injected into the skin must be surgically removed within a few hours or gangrene may result. Doctors unfamiliar with this type of injury should reference a knowledgeable medical source. Such information is available from Deere & Company Medical Department in Moline, Illinois, U.S.A. Information may be obtained in the United States and Canada only by calling 1-800-822-8262.

Dispose of Chemicals Properly

- Proper disposal of excess spray material is very important. If you have excess tank solution, it is best to dilute it with water and apply it to the area you previously treated.
- Never dump solution into a drain or near a lake or stream.
- Chemicals containers should be triple-rinsed, with the rinse water added to the sprayer tank. Do not burn empty chemical containers. Dispose of containers at recycling centers.

Handling Waste Product and Chemicals

Waste products, such as, used oil, fuel, coolant, brake fluid, and batteries, can harm the environment and people:

- Do not use beverage containers for waste fluids - someone may drink from them.
- See your local Recycling Center or authorized dealer to learn how to recycle or get rid of waste products.
- A Material Safety Data Sheet (MSDS) provides specific details on chemical products: physical and health hazards, safety procedures, and emergency response techniques. The seller of the chemical products used with your machine is responsible for providing the MSDS for that product.

Assembly

Parts List (X300, X500 Installation)

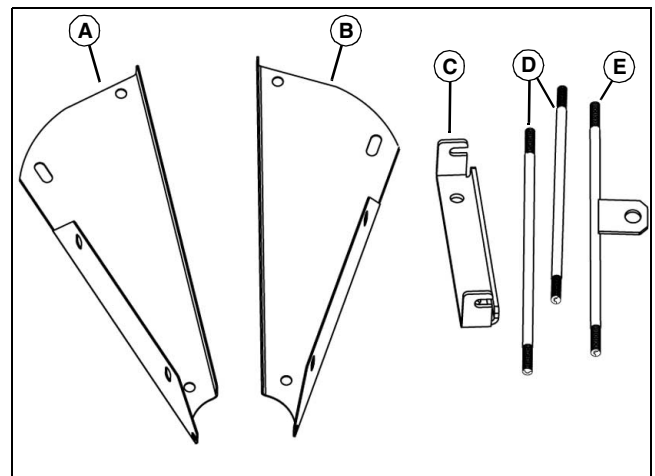

MX27834

Qty.	Description
1	Tank Support, Right (A)
1	Tank Support, Left (B)
1	Anchor Bracket (C)
2	Rod, 1/2-in. (D)
1	Rod with Drawbar, 1/2-in. (E)
1	Boom Assembly
1	Tank Assembly
4	Flange Head Bolt, 5/16 x 5/8

Assembly

Qty.	Description
2	Truss Head Bolt, 5/16 x 1
4	Flat Washer, 3/8
2	Flange Nut, 5/16
4	Lockwasher, 1/2
4	Flange Nut, 1/2
8	Hex Nut, 1/2
2	Anchor Pin
2	Lockwasher, 5/8
8	Flat Washer, 5/8
4	Hex Nut, 5/8
1	Drawbar Pin, 3/4
3	Clip Pin
2	Wire Clip, Plastic
1	Wire Harness
2	Tie Wrap

face to face of tank supports.

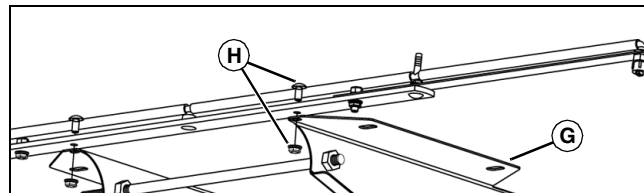

MX27825

6. Install boom assembly (G) to frame with two 5/16 truss head bolts and 5/16 flange nuts (H).

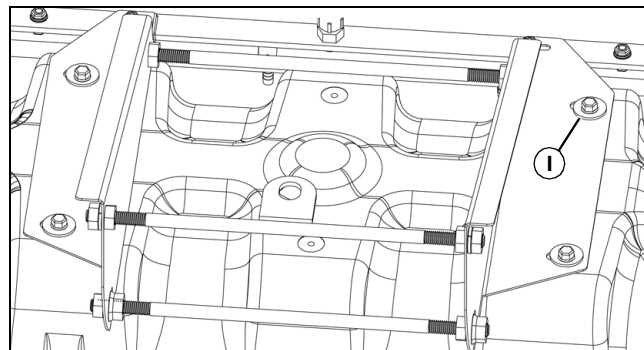

MX27826

7. Secure tank assembly to left and right frames with four 3/8 flat washers and 5/16 x 5/8 flange bolts (I).

8. Position tank with spray wand to front. Tighten bolts to 14 N•m (10 lb-ft).

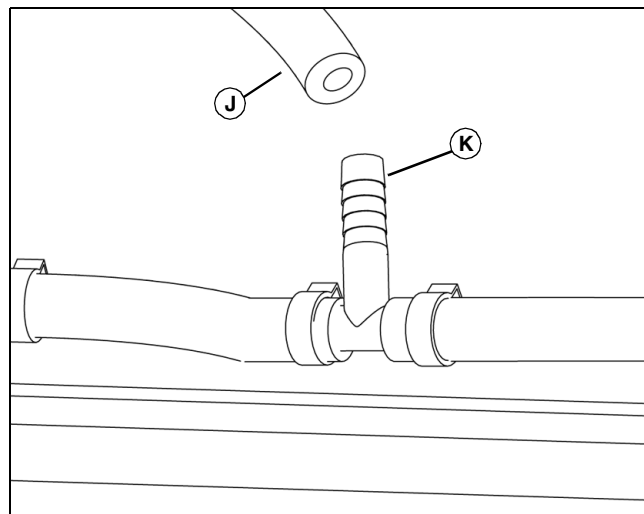

MX27827

9. Connect boom hose (J) on tank assembly to tee fitting (K) on boom assembly (no clamp required).

Assemble Tank (X300, X500)

NOTE: Distance from inside face to face of tank supports must be 13-1/2 inches (E), and can be adjusted with 1/2-in. nuts.

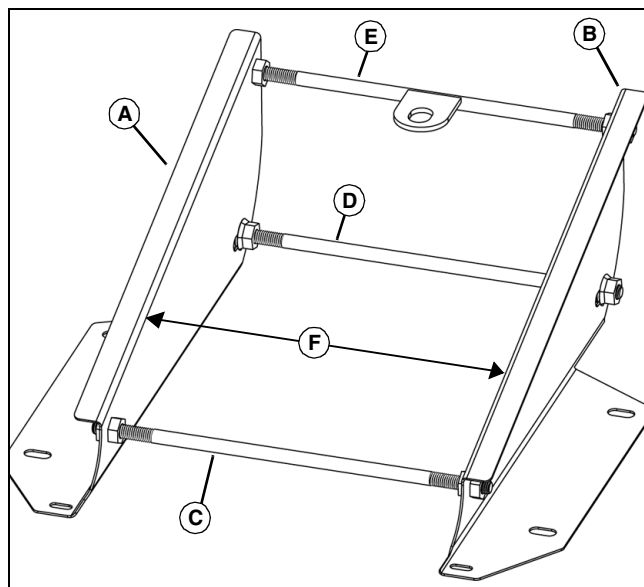

MX27824

1. Position left and right tank supports (A and B) as shown.
2. Install one 1/2-in. rod (C) in rear position with four 1/2-in. hex nuts and two 1/2-in. lockwashers.
3. Install one 1/2-in. rod (D) in front slotted position with four 1/2-in. flange nuts.
4. Install 1/2-in. rod with drawbar (E) in front top with four 1/2-in. hex nuts and two 1/2-in. lockwashers.
5. Adjust 1/2-in. nuts to obtain distance of 13-1/2 inches (F) from inside

Install Anchor Mount and Sprayer (X300, X500)

Install Anchor Mount

Assembly

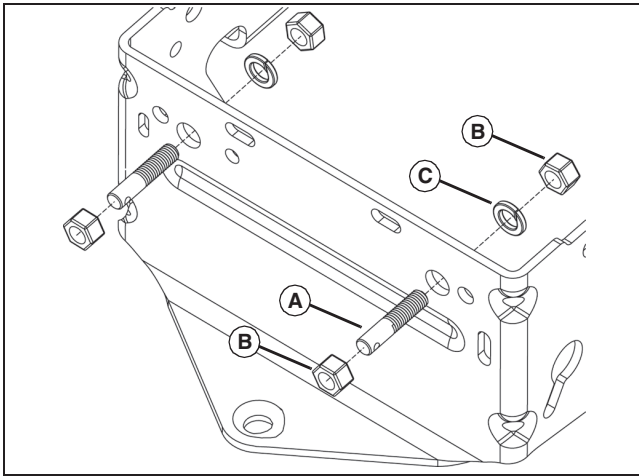

MX27828

1. 2-wheel steering tractor: Position threaded anchor pin (A) with hole to outside of frame and horizontal and loosely secure on rear frame of tractor with two 5/8 hex nuts (B) and one 5/8 lockwasher (C).

2. Install second threaded anchor pin.

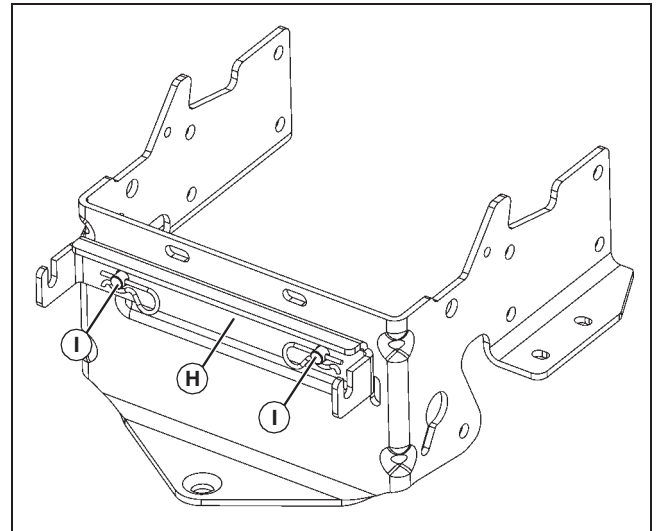

MX45505

5. Install anchor bracket (H) to anchor pins and secure with spring clip pins (I). Adjust nuts on anchor pins to snug bracket and tighten hardware.

Spring clip pins should be loose enough to be removed for tractor anchor removal. Anchor pins can remain installed on tractor frame.

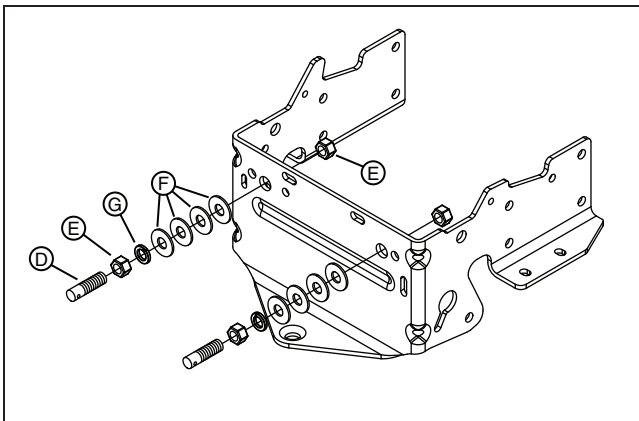

3. 4-wheel steering tractor: Position threaded anchor pin (D) with hole to outside of frame and horizontal and loosely secure on rear frame of tractor with two 5/8 hex nuts (E), four 5/8 flat washers (F), and one 5/8 lockwasher (G).

4. Install second threaded anchor pin.

Assembly

Install Sprayer

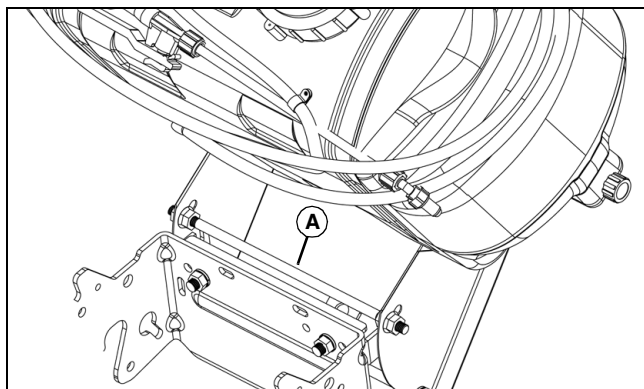

MX27831

1. Angle sprayer and place top rod (A) into holding slots in anchor bracket.

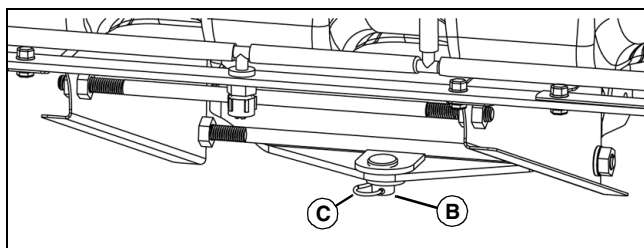

MX27832

2. Place 3/4-in. drilled pin (B) through tractor hitch and slot of drawbar. Insert spring clip pin (C) to lock assembly in place.

3. Adjust rod positions in left and right frame slots to level sprayer.

Parts List (X700 Installation)

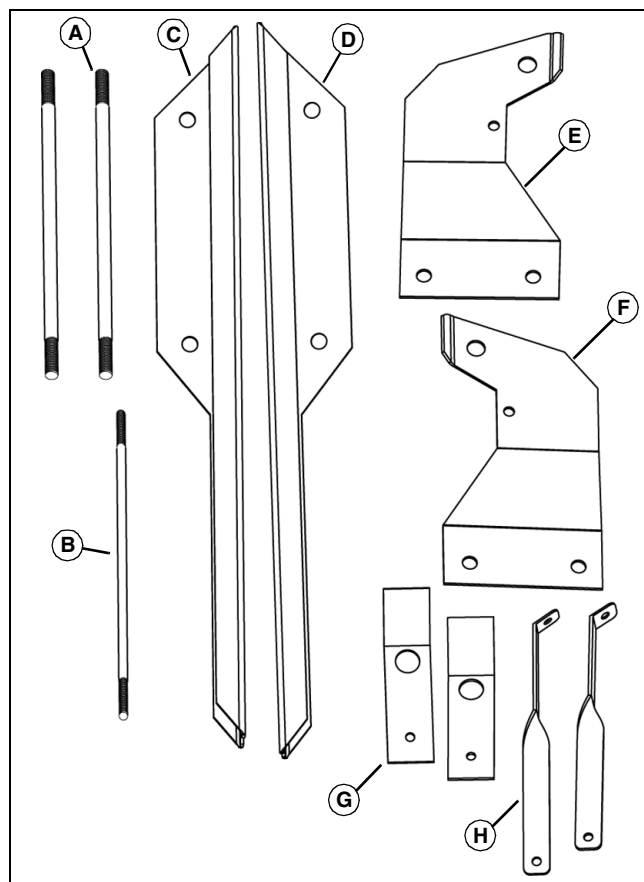

MX27836

Qty.	Description
2	Rod, 1/2-in. (A)
1	Rod, 3/8-in. (B)
1	Support Channel, Left (C)
1	Support Channel, Right (D)
1	Support Bracket, Left (E)
1	Support Bracket, Right (F)
2	Latch Lever (G)
2	Boom Support Bracket (H)
1	Boom Assembly
1	Tank Assembly
2	Machine Bolt, 1/4 x 2
2	Nylock Nut, 1/4
6	Flange Head Bolt, 5/16 x 5/8
2	Truss Head Bolt, 5/16 x 1
4	Flange Nut, 5/16
4	Flat Washer, 3/8

Assembly

Qty.	Description
2	Lockwasher, 3/8
4	Hex Nut, 3/8
4	Lockwasher, 1/2
8	Hex Nut, 1/2
2	Spring
2	Wire Clip, Plastic
1	Wire Harness

edges of the support channels to be approximately 395 mm (15-9/16 in.) (J). Tighten 3/8 in. and 1/2 in. hex nuts to secure position.

Assemble Tank (X700)

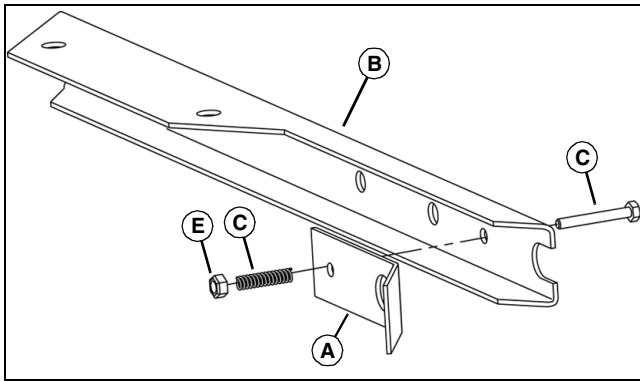

MX27838

1. Secure latch levers (A) to left and right support channels (B) with a 1/4 x 2 machine bolt (C), spring (D), and 1/4 Nylock nut (E).

NOTE: Assemble support brackets as shown.

Lockwashers must be placed on inside of support channels.

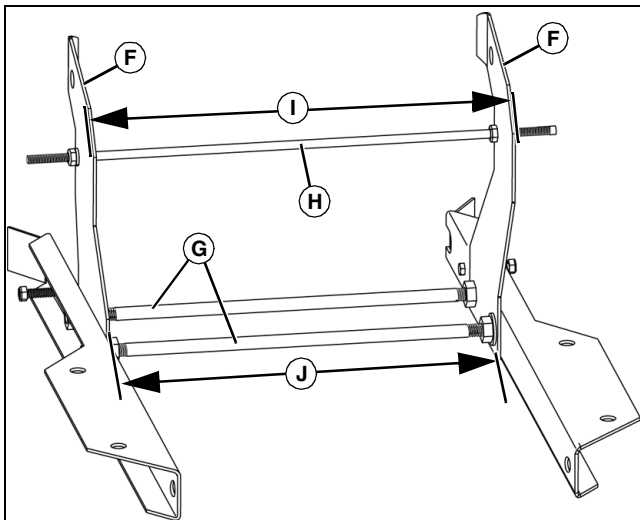

MX27839

2. Install left and right support brackets (F) to left and right support channels with two 1/2-in. rods (G), four 1/2 in. lockwashers, and with eight 1/2 in. hex nuts. Place lockwashers in inside of support channel.

3. Install 3/8 in. rod (H) to left and right support brackets with four 3/8 in. flange nuts.

4. Adjust distance between the outside edges of the attaching plates to be approximately 425 mm (16-3/4 in.) (I). Adjust the distance between inside

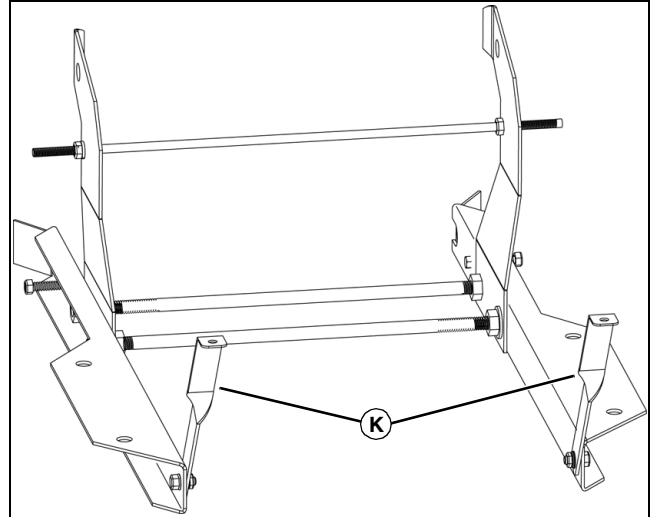

MX27840

5. Install boom supports (K) to left and right support channels with two 5/16 x 5/8 flange bolts and 5/16 flange nuts.

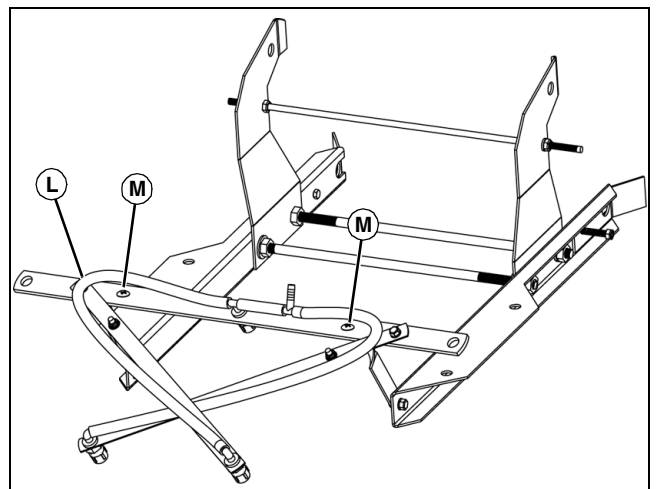

MX27841

6. Install boom assembly (L) to frame with two 5/16 truss head bolts (M) and two 5/16 flange nuts. Insert bolts down through boom with nuts on backside of boom supports.

Assembly

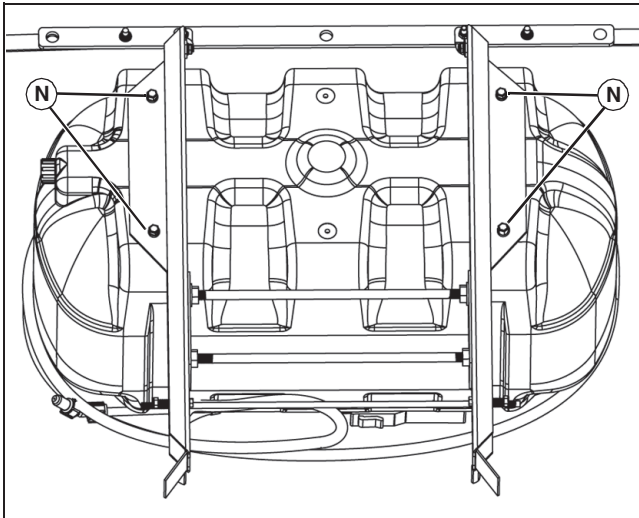

MX27842

7. Secure tank assembly to left and right support channels with four 5/16 x 5/8 in. bolts and four 3/8 in. flat washers (N). Position tank with spray wand to front.

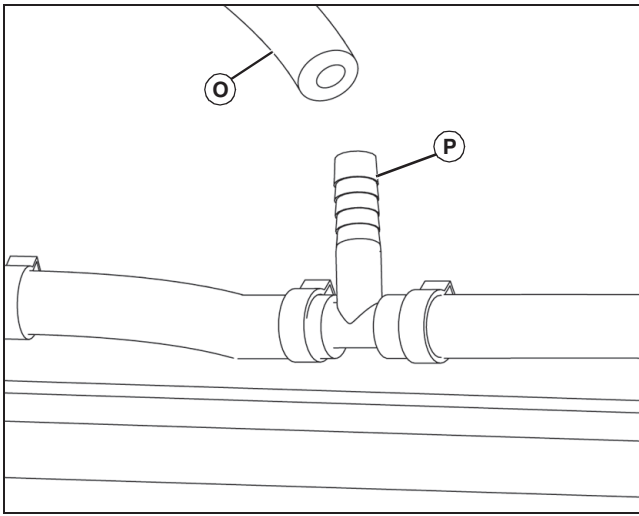

MX27827

8. Connect boom hose (O) on tank assembly to tee fitting (P) on boom assembly (no clamp required).

Install Sprayer (X700)

NOTE: Ultimate series requires Click N Go brackets.

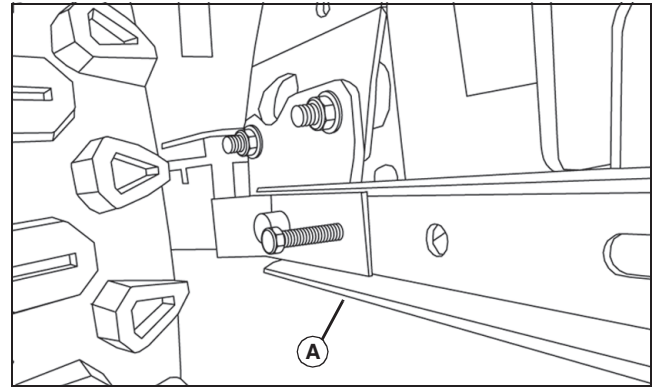

MX27843

1. Slide support channels (A) over Click N Go, and lower pins until they click securely into place.

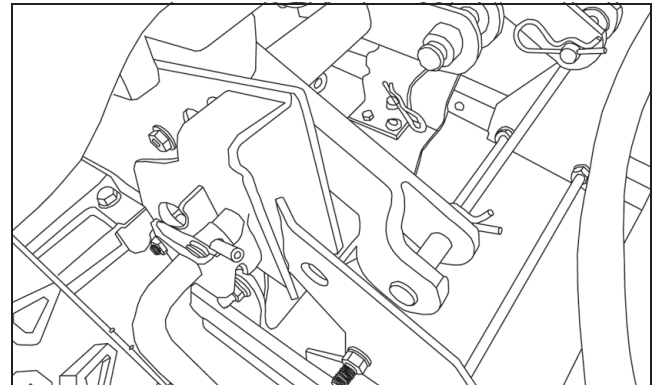

MX27844

2. Lift back of sprayer until support bracket top holes line up with Click N Go bracket top pins. Use pins to secure sprayer in place.

Install Wiring Harness to Battery

X300 and X500 Wiring Harness Setup

- Depending on the location of your battery, a wiring harness extension may be required. See your John Deere dealer to order part.

Installing

Install Harness

IMPORTANT: Avoid damage! To help prevent electrical spark, install red wire to the positive (+) battery terminal first. Then install black wire to negative (-) battery terminal.

To prevent damage to wiring, make sure hood does not close on wires or connectors.

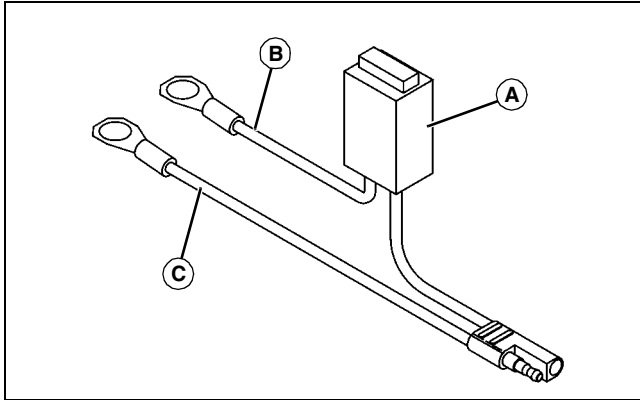

MX34799

1. Fuse holder (A) should contain a 15 A / 32 V fuse. Make sure fuse filament is not broken.
2. Open hood. If battery is mounted low and behind the grille, carefully unsnap top of grille to provide access to battery terminals.
3. Remove nut from positive (+) battery cable clamp. Install red lead (B) onto clamp bolt. Install and tighten nut completely.
4. Remove nut from negative (-) battery cable clamp. Install black lead (C) onto clamp bolt. Install and tighten nut completely.

Install Wiring Harness Extension (For Machines With Upper Front-Mounted Battery)

NOTE: Wiring Harness Extension is required. See your John Deere dealer to order parts.

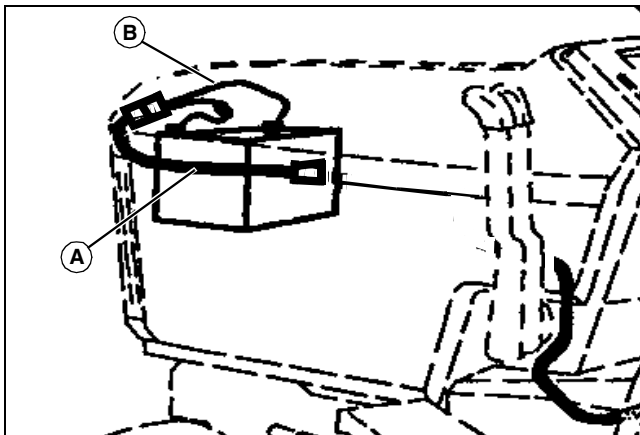

M94107, MIF

Connect wiring harness extension (A) to fused harness (B) at battery. Make sure the harness passes between the left side hood rods.

Install Wiring Harness Extension (For Machines With Lower Front-Mounted Battery)

NOTE: Wiring Harness Extension is required. See your John Deere dealer to order parts.

1. Route wiring harness extension through front frame hole.
2. Connect extension to battery lead plug. Then snap front grille in place.

Install Wire Clips

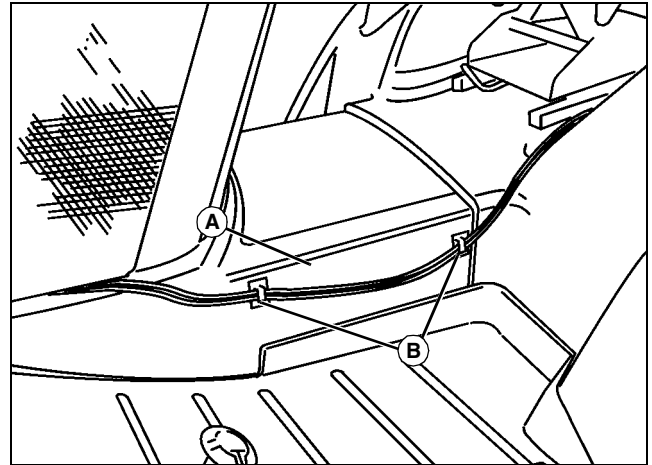

MX34789

1. Clean foot rest side panel (A) at left side of machine with mild detergent or isopropyl alcohol. Dry thoroughly.
2. Attach wire clips (B) to panel. Position the clips as shown so that sprayer main wiring harness will not interfere with deck height adjustment crank, if equipped.

Installing

Install Wiring Harness (For Machines With Mid-Mounted Battery)

1. Open hood.

NOTE: Switch (A) is not located at center of main wiring harness. The harness plug connector nearest to the switch gets connected to the pump leads.

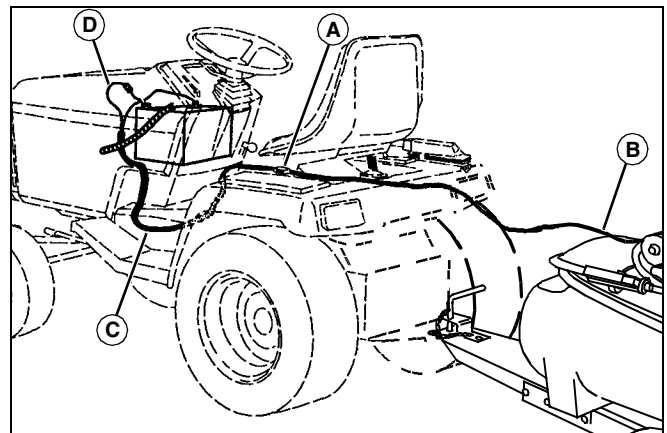

M94107, MIF

Picture Note: Wheeled Sprayer Shown

2. Connect main wiring harness to pump leads (B).
3. Route main harness as shown and clip in place at foot rest side panel (C). On some units route harness on right side of fuel tank filler neck.

Preparing Vehicle

IMPORTANT: Avoid damage! Avoid damage to wiring. Make sure hood does not close on wiring harnesses. Keep wiring harnesses away from all moving parts and hot surfaces.

4. Connect other end of main harness to fused battery lead (D).
5. Close hood.

Install Wiring Harness (For Machines With Upper Front-Mounted Battery)

1. Open hood.

NOTE: Switch (A) is not located at center of main wiring harness. The harness wiring connector nearest to the switch gets connected to the pump leads.

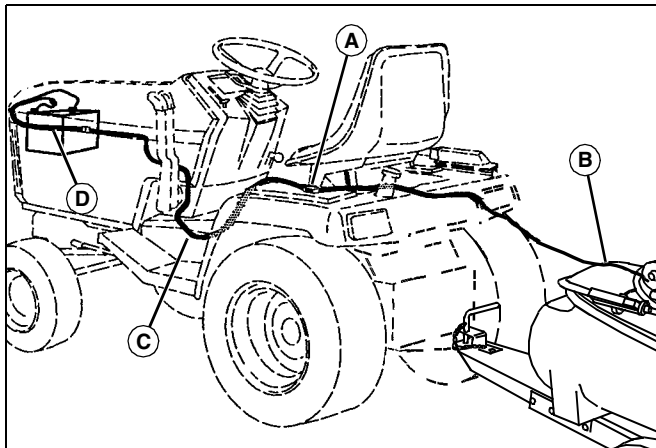

M94107a, MIF

Picture Note: Wheeled Sprayer Shown

2. Connect main wiring harness to pump leads (B).
3. Route main harness as shown. Clip harness in place at foot rest side panel (C). On some units route harness on right side of fuel tank filler neck.

IMPORTANT: Avoid damage! Avoid damage to wiring. Make sure hood does not close on wiring harnesses. Keep wiring harnesses away from all moving parts and hot surfaces.

4. Make sure harness extension (D) passes between the left side hood rods. Connect the main harness to the wiring harness extension.
5. Close hood.

Preparing Vehicle

Machine Requirements

Make sure machine tire pressure is correct for attachment weight. (See your machine operator's manual for the correct pressure.)

Your machine requires the following:

- 12-Volt battery and alternator

Install Ballast



CAUTION: Avoid injury! Machine can become unstable when operating with attachment. Ballast is required when the attachment is installed.

When the attachment is removed, also remove any ballast that was added to the machine.

Use only attachments and accessories recommended by the manufacturer.

NOTE: Ballast weights can be purchased from your John Deere dealer.

All machines using this sprayer require installation of one of the following:

- Mid-mount mower
- Front attachment
- Four front suitcase weights, or two front wheel weights

Removing and Storing

Removing Sprayer From X300, X500

1. Park machine safely. (See Parking Safely in the Safety section.)



CAUTION: Avoid injury! To avoid chemical injury:

- Wear protective clothes, gloves and goggles when handling sprayer.
- Do not store sprayer with chemicals in tank.
- If spray comes in contact with your body, immediately follow directions on chemical container pertaining to spray material.

2. Empty the sprayer tank.

NOTE: Battery harness with fuse should not be removed.

3. Disconnect main wiring harness only. Leave all other harnesses installed on tractor.
4. Roll up main harness and store with sprayer.

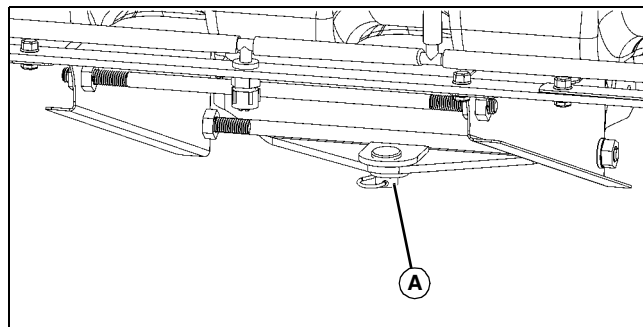

MX45498

5. Remove 3/4 in. pin (A).

Removing and Storing

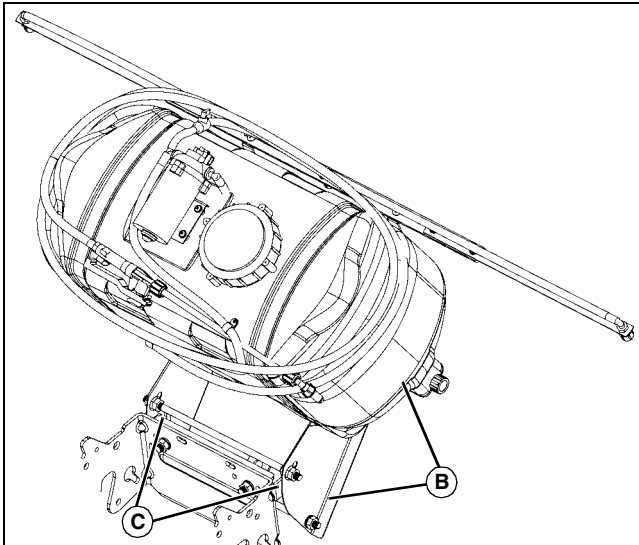

6. Lift sprayer (B) off tractor anchor (C).
7. Sprayer anchor bracket can be left on the tractor. It will not interfere with any other attachments.

Removing Sprayer From X700

1. Park machine safely. (See Parking Safely in the Safety section.)



CAUTION: Avoid injury! To avoid chemical injury:

- Wear protective clothes, gloves and goggles when handling sprayer.
- Do not store sprayer with chemicals in tank.
- If spray comes in contact with your body, immediately follow directions on chemical container pertaining to spray material.

2. Empty the sprayer tank.

NOTE: Battery harness with fuse should not be removed.

3. Disconnect main wiring harness only. Leave all other harnesses installed on tractor.
4. Roll up main harness and store with sprayer.

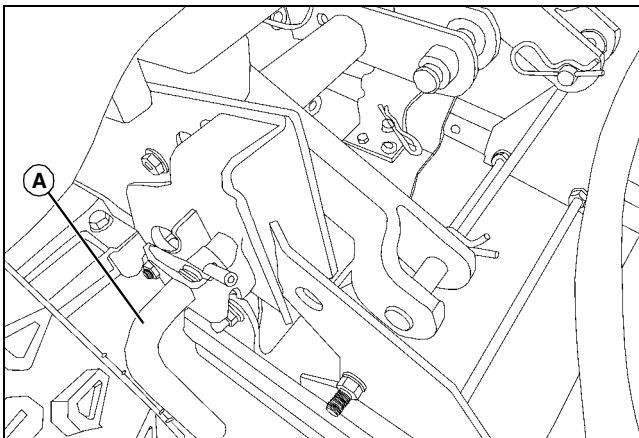

5. Lift back of sprayer and move Click-N-Go pins (A) to storage position.

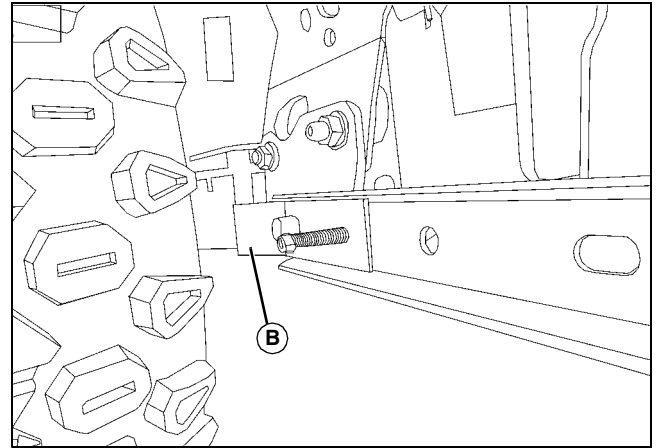

6. Open the Click-N-Go lower levers (B) and remove the sprayer from the tractor.

Store Sprayer Safely



CAUTION: Avoid injury! To avoid chemical injury:

- Wear protective clothes, gloves and goggles when handling sprayer.
- Do not store sprayer with chemicals in tank.
- If spray comes in contact with your body, immediately follow directions on chemical container pertaining to spray material.

1. Pump all spray material from tank. (See Dispose of Chemicals Properly in the SAFETY section.)
2. Rinse tank, pump, spray wand and all hoses thoroughly with fresh clean water.
3. Repeat step 2 several times.
4. Wipe out sump with a clean cloth or paper towel.
5. Drain hoses and pump filter.
6. Check sprayer for worn or damaged parts. Replace parts as needed.
7. Tighten loose hardware.
8. Store sprayer in a place where it will not freeze.

Operating

Operating

Filling Sprayer Tank



CAUTION: Avoid injury! Chemicals can be dangerous. Avoid injury to operator or bystanders:

- Read chemical container label for mixing and handling instructions. A Material Safety Data Sheet (MSDS) should be supplied by the chemical dealer and provides proper safety information.
- Wear proper clothing and safety equipment while handling or applying spray chemicals.
- Wear a full covering of clothing, protective goggles and rubber gloves.
- Prohibit all smoking, drinking, and eating around chemicals.
- When filling tank, never allow end of water hose to contact chemical mixture.

IMPORTANT: Avoid damage! Clean any spills immediately with clean water prior to operating the sprayer.

1. Clean area around tank filler cap to prevent tank contamination.
2. Remove tank filler cap and fill tank.
3. Install tank filler cap.

Draining and Cleaning Sprayer Tank

IMPORTANT: Avoid damage!

- Proper disposal of excess spray is very important. Dilute it with water and apply it to area previously treated.
- Never dump excess into a storm drain or near a lake or stream.

1. The preferred method of cleaning is to dilute remaining material with water and apply it to the area previously treated:
 - If excess material remains, remove drain cap and empty remaining material into an appropriate container for reuse or for disposal according to local regulations or as specified in the manufacturer's label.

NOTE: Be sure to visibly label the container contents for safety.

2. Spray all inside surfaces of tank with low pressure garden hose to remove any remaining solution. Replace the drain cap and run clean water through the pump, hoses and boom applying those contaminated contents on previously treated area.
3. Rinse outside of sprayer tank thoroughly with fresh clean water. Rinse several times to make sure sprayer tank is clean and free of chemicals.
4. Once the tank is empty, wipe out inside of sprayer tank with a clean cloth or paper towel.
5. Install drain cap and filler cap.

Operating Spray Wand

NOTE: It is not recommended to use wand while operating the machine. Turn machine on for wand use, but do not maneuver machine unless wand and hose are in normal storage position on the tank.

1. Turn shut-off valve lever perpendicular to hose.

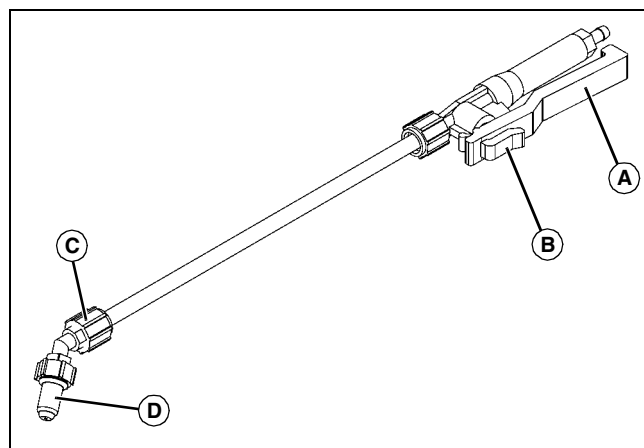

MX45502

2. Squeeze handle (A) to spray.
 - Push lock (B) forward to lock handle into the on position.
3. Adjust nozzle:
 - Nozzle Angle - Loosen locknut (C). Turn nozzle (D) as desired and tighten locknut.
 - Nozzle Spray Pattern - To change spray pattern, tighten or loosen nozzle (D) as desired.

Spraying Tips

- Do not let sprayer run in one spot.
- Do not over spray when you use weed killers.
- Liquid spray material is recommended. Sprayer does not agitate wettable powders.
- Timely applications of a smaller dosage are better than large applications.
- Turn sprayer off during turns to avoid double spraying.
- Fill sprayer where spills cannot harm grass.
- Follow manufacturer's recommendations for application of specific chemicals.
- Stop sprayer when tank is empty.
- Always purge air from spray wand at start of spraying session.

Checking Machine Ground Speed

1. Drive vehicle and sprayer (half-full is optimal) across a measured distance at a constant speed. There can be no change in speed while measuring time. Speed should be a comfortable speed for spraying.
2. Have someone measure the amount of time (in seconds) it takes to travel the measured distance.
3. Speed can be found by entering data into the equation: speed (mph) = distance (ft) x 60/time (sec) x 88, or by consulting the following table. It is helpful to note throttle location, gear and/or RPMs in order to maintain accuracy.

Speed in mph	Time (sec) required to travel a distance of:	
	200 ft	300 ft
1	136	205
1.5	91	136

Operating

2	68	102
2.5	55	82
3	45	68
3.5	39	58
4	34	51
4.5	30	45
5	27	41
5.5	25	37
6	23	34
6.5	21	31
7	19	29

General Spraying Information

25 Gallon Sprayer Application:

The 25 gallon sprayer operates at a fixed pressure through the boom and spray wand. Although the pressure can be adjusted to the boom by partially opening the boom control valve, it is recommended that the valve is operated in full open position. Use the chart below to select your desired speed and application rate.

GPA (gallons per acre per nozzle)					
Model	2 mph	3 mph	4 mph	5 mph	6 mph
25 Mounted	54.5	36.3	27.2	21.8	18.2
Gallons per 1000 sq ft per nozzle					
Model	2 mph	3 mph	4 mph	5 mph	6 mph
25 Mounted	1.25	0.83	0.63	0.50	0.42

Standard Hand Wand			
Pressure	Nozzle	GPM (cone)	GPM (stream)
80 psi	#18	0.4	1.25
Sprayer Capacity		Approximate Spray Time in Minutes	
25		62.5	20

Adjusting Spray Tips

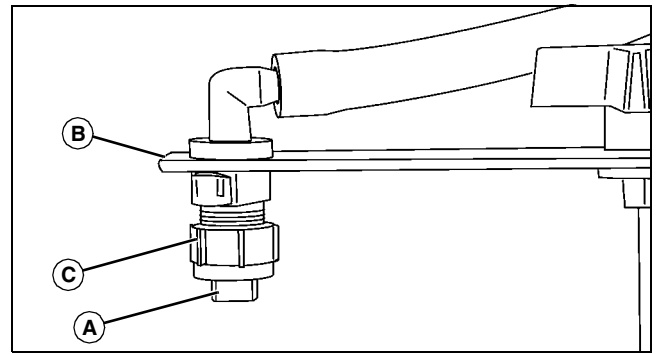

MX34862

1. Check spray tips (A):

- Tips should be aligned with boom (B) as shown. If necessary, loosen spray tip cap nut (C). Align spray tip and tighten cap nut.

2. Test spray pattern with water on driveway or sidewalk, and adjust as necessary. Each spray tip pattern should spread out to the right and left sides, rather than to the front and back of the boom. There should be some spray overlap between each tip and the spray patterns should be consistent.

Starting and Stopping Sprayer

IMPORTANT: Avoid damage! Operate sprayer with transport vehicle running to avoid discharging the battery.

NOTE: The sprayer pump to battery hookup is a direct electrical connection. Shutting off the transport vehicle does not prevent operation of the sprayer pump. To avoid accidental spraying, disconnect the pump connection before leaving the sprayer.

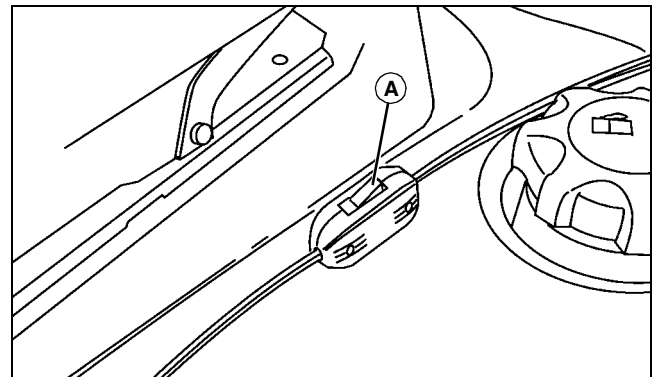

MX34797

Push switch (A) to on or off position to start or stop sprayer.

Service

Selecting Spray Wand or Boom Nozzles

NOTE: Shut-off valve lever (A) has two positions:

- **ON POSITION** - Lever is parallel with hose. Pump flow is directed to the sprayer boom.
- **OFF POSITION** - Lever is perpendicular with hose. Pump flow is directed to the spray wand.

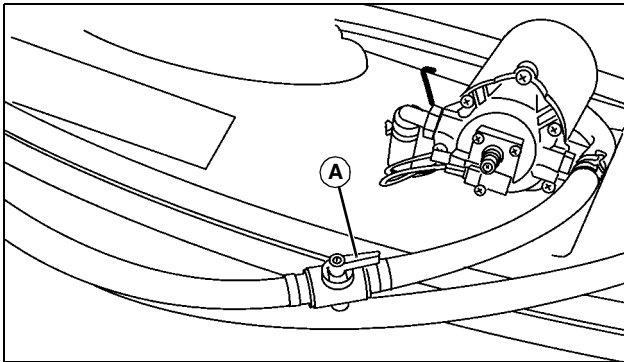

MX34863

- To use spray wand: Turn lever (A) so that it is perpendicular with hose. You can now use the spray wand for spraying.
- To use sprayer boom: Turn lever (A) so that it is parallel with hose. Turn pump on and operate spray wand to remove all air from hose. After spray wand sprays liquid, turn pump off. Turn lever (A) so that it is parallel with hose. You can now use the boom nozzles for spraying.

Service

Cleaning Spray Nozzle



CAUTION: Avoid injury! Do not put nozzle tip or other sprayer parts to your lips to blow out dirt. Use compressed air or clean water.

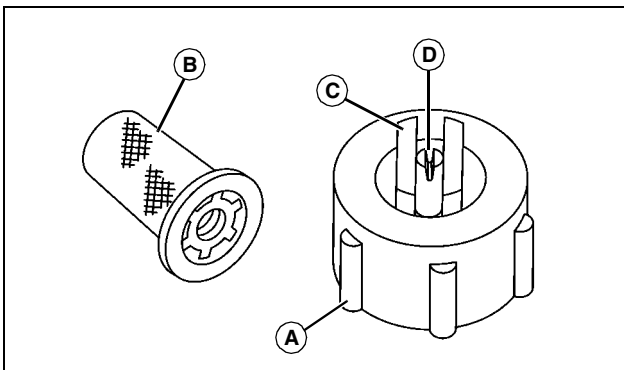

MX34868

1. Remove spray nozzle (A) from sprayer.
2. Disassemble filter (B) and spray tip (C).

NOTE: Do not use a wire to clean opening (D) in spray tip.

3. Wash filter and spray tip in a non-flammable solvent.
4. Put spray tip in spray nozzle.
5. Put flat side of filter in spray nozzle.
6. Install assembly on sprayer and tighten nozzle.

Cleaning Pump Suction Screen

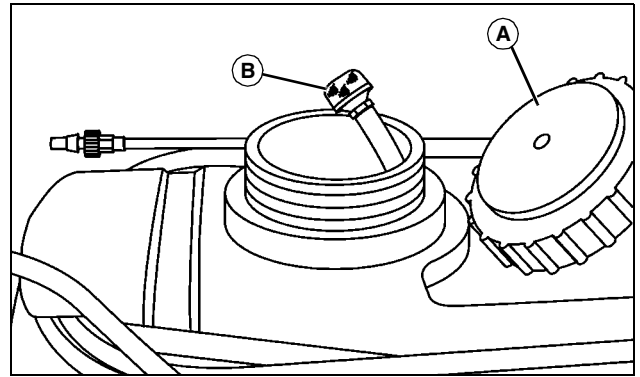

MX34869

1. Remove tank cover (A).
2. Locate suction screen (B) inside sprayer tank.
3. If necessary, unscrew suction screen and clean with liquid detergent and warm water.
4. If suction screen was removed, install on suction hose and position in lowest depression inside tank.
5. Install and tighten tank cover.

Cleaning Spray Wand Nozzle

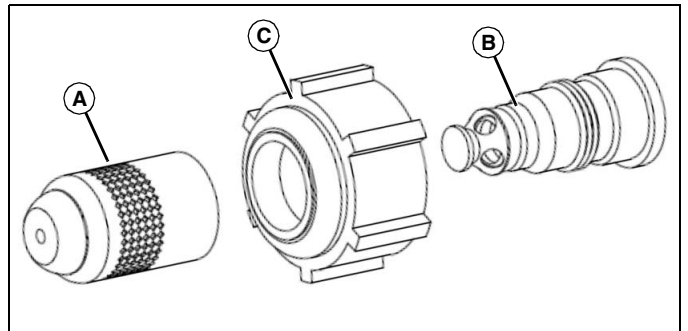

MX28420

1. Unscrew nozzle (A) from spray tip (B).
2. Loosen nut (C) and remove spray tip (B) from angled fitting on wand.
3. Wash nozzle and spray tip with liquid detergent and warm water.
4. Inspect O-rings and replace as needed.
5. Slide nut over spray tip and install on angled fitting on wand.
6. Install nozzle on spray tip.

Changing Fuse

IMPORTANT: Avoid damage! The electrical system may be damaged if incorrect replacement fuses are used. Replace the bad fuse with a fuse of the same amp rating.

1. Open hood.

Troubleshooting

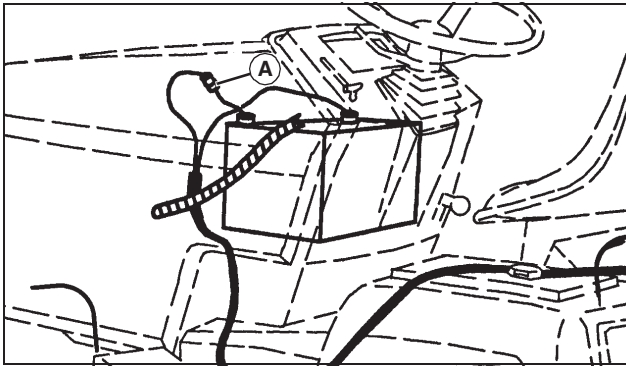

M61159

2. Remove fuse (A).
3. Install new 15 amp fuse.
4. Close hood.

Troubleshooting

Using Troubleshooting Chart

If you are experiencing a problem that is not listed in this chart, see your authorized dealer for service.

When you have checked all the possible causes listed and you are still experiencing the problem, see your authorized dealer.

Using Troubleshooting Chart

IF	CHECK
Pump Loses Suction.	Clean Pump suction screen. Check tank fill level. Fill tank. Clean or replace pump. Check for loose pump fittings.
Pump Capacity Decreased.	Clean pump suction screen. Clean spray nozzle(s). Selection lever is not completely turned on, or is in the OFF position.
Poor Spray Pattern.	Clean spray nozzles. Adjust nozzle height. Align spray tips with boom.
Pump Does Not Work.	Check wiring connections. Check machine battery. Clean debris from pump. Check pump switch. Check pump motor. Check fuse at battery.

Specifications

Model 25 Gallon Sprayer

Tank Capacity 95 L (25 gallon)

Pump:

Type Electric Motor and Diaphragm
 Manufacturer Deere
 Current Draw 7 amp
 Fuse 15 amp
 System Pressure 689 kPa (100 psi)

Spray Rate 8.3 L/min (2.2 gal/min)

Suction Hose Strainer Stainless Steel

Spray Tip Material Plastic

Spray Wand:

Material Plastic

Sprayer:

Nozzle Tip Height 43 cm (17 in)

Spraying Width 229 cm (90 in)

Weight (Installed on X300, X500 Tractor)

Empty 13 kg (30 lb)

Full 108 kg (240 lb)

Weight (Installed on X700 Tractor)

Empty 19 kg (42 lb)

Full 114 kg (252 lb)

Getting Quality Service

John Deere Quality Continues with Quality Service

John Deere provides a process to handle your questions or problems, should they arise, to ensure that product quality continues with quality parts and service support.

Follow the steps below to get answers to any questions you may have about your product.

1. Refer to your attachment and machine operator manuals.
2. In North America or Canada, call John Deere Special Services at 1-800-448-9282 and provide product serial number (if available) and model number.

Standard Sprayer Recirculation Supplement

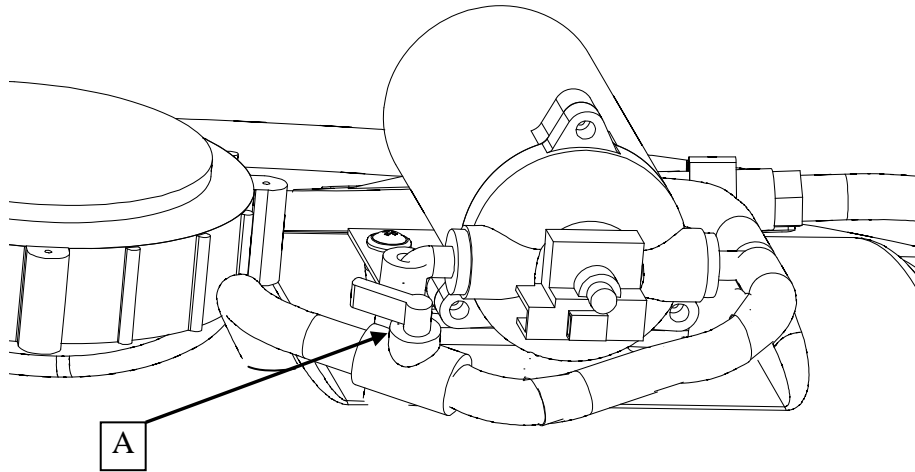

The sprayer is equipped with a recirculation valve (A) to aid in material agitation and pressure control. The location of this valve will vary with the sprayer model. This valve is in the “open” position when the valve handle is in line with the hose (pictured), “closed” when perpendicular to the hose.

Adjusting the recirculation valve between the open/closed positions will affect the pressure coming through the spray wand or boom tips.

- Closed position is full pressure through spray wand or boom.
- It may be helpful to adjust the pressure when spraying with the spray wand to avoid damage to plants from excess pressure.
- If your sprayer is equipped with a boom, this valve should be in the “closed” position when operating the boom.

