

JOHN DEERE
AG & TURF DIVISION

Wheeled and Portable Sprayers
15, 25 and 45 Gallon
04/05/22
OMM160897 K1
OPERATOR'S MANUAL



JOHN DEERE

Original Instruction

All information, illustrations and specifications in this manual are based on the latest information at the time of publication. The right is reserved to make changes at any time without notice.

COPYRIGHT© 2011

Deere & Co.

John Deere Ag & Turf Division

All rights reserved

Previous Editions

COPYRIGHT© 2009, 2010

North American Version

Printed in U.S.A.

Introduction

Table of Contents

Introduction.....	1
Product Identification.....	1
Safety	2
Assembly.....	4
Installing	10
Preparing Vehicle	12
Removing and Storing.....	12
Operating.....	14
Service	18
Troubleshooting	19
Specifications	19
Getting Quality Service	20

Introduction

Using Your Operator's Manual

Read this entire operator's manual, especially the safety information, before operating.

This manual is an important part of your machine. Keep all manuals in a convenient location so they can be accessed easily.

Use the safety and operating information in the attachment operator's manual, along with the machine operator's manual, to operate and service the attachment safely and correctly.

If your attachment manual has a section called Preparing the Machine, it means that you will have to do something to your tractor or vehicle before you can install the attachment. The Assembly and Installation sections of this manual provide information to assemble and install the attachment to your tractor or vehicle. Use the Service section to make any needed adjustments and routine service to your attachment.

If you have any questions or concerns with the assembly, installation, or operation of this attachment, see your local John Deere dealer or call the John Deere Customer Contact Center at 1-800-448-9282 for assistance.

Warranty information on this John Deere attachment can be found in the warranty that came with your John Deere tractor or vehicle.

Product Identification

Product Compatibility

These Sprayers are designed for use with John Deere riding lawn and garden products and John Deere utility vehicles.

Contact your John Deere dealer for specific machine compatibility information.

Safety

Safety

Read Safety in Machine Operator's Manual

Read the general safety operating precautions in your machine operator's manual for additional safety information.

Operate Safely

- Read the machine and attachment operator's manual carefully. Be thoroughly familiar with the controls and the proper use of the equipment. Know how to stop the machine and disengage the controls quickly.
- Do not let children or an untrained person operate machine.
- Make any necessary adjustments before you operate. Never attempt to make any adjustments while the engine is running, unless if recommended in adjustment procedure.
- Take all possible precautions when leaving the machine unattended. Shut off the engine before making any repairs, adjustments, or inspections. Lower the attachment, lock the parking brake, stop the engine, and remove the key.
- Look behind machine before you back up. Back up carefully.
- Do not let anyone, especially children, ride on machine or attachment. Riders are subject to injury such as being struck by foreign objects and being thrown off. Riders may also obstruct the operator's view, resulting in the machine being operated in an unsafe manner.
- Use only attachments and accessories approved by the manufacturer of this product.
- If the machine vibrates abnormally, stop the engine and check immediately for the cause. Vibration is generally a warning of trouble.
- Always refer to the Storage section of the operator's manual for important details if storing this product for a long period of time.
- Keep people and pets out of the work area. Stop machine if anyone enters the area.
- If you hit an object, stop the machine and inspect it. Make repairs before you operate. Keep machine properly maintained and in good working order. Keep all shields and guards in place.
- Always inspect the sprayer completely before and after each use. Before pressurizing the system, check to be sure all fittings and hoses are tightly installed. Be sure guards and shields are in good condition and fastened in place. Make any necessary adjustments before you operate.
- Never use the sprayer during windy conditions.
- Always release pressure in the system before filling, cleaning or servicing the sprayer.
- Do not put nozzle tip or other sprayer parts to your lips to blow out dirt. Use compressed air.
- If the sprayer is mounted to the bed of a utility vehicle, never raise the bed with the sprayer installed. Empty the sprayer and remove it from the bed if you need to raise the bed for any reason.

Parking Safely

1. Stop vehicle on a level surface, not on a slope.
2. Lock park brake.
3. Stop engine.
4. Remove key.
5. Before you leave the operator's seat, wait for engine and all moving parts to stop.

6. Disconnect the negative battery cable or remove the spark plug wire (for gasoline engines) before servicing the machine.

Mix and Handle Chemicals Safely

- It is best to wear full cover clothing and always wear protective goggles and rubber gloves to protect yourself while handling chemicals.
- Follow instructions on chemical container labels.
- Open all chemical containers carefully, using proper tools.
- Open, pour, weigh and mix chemicals in a well-ventilated area.
- Reserve all equipment used for the application of chemicals exclusively for that purpose.
- Prohibit all smoking, drinking and eating food in chemical-handling area.
- It is a good practice to take a soapy shower immediately after the using the sprayer to apply chemicals.
- Wash all clothing worn when using chemicals separately in the laundry after spraying is completed.

Read Chemical Container Label

- Chemicals can be dangerous. Improper selection or use can injure persons, animals, plants, soils or other property. Select the right chemical for the job and handle and apply with care.
- Read the instructions, precautions, and warnings on the container label before opening. Use the product strictly according to label directions for specific applications, in the amounts specified, at the times specified and only when needed.
- Keep the container closed tightly except when preparing the mix.
- Do not remove labels from chemical containers. Store all chemicals in their original containers.
- Do not mix chemicals unless stated on the container label.
- Store chemicals when not in use according to the container label.

Handle Chemical Products Safely

- Direct exposure to hazardous chemicals can cause serious injury. Potentially hazardous chemicals used with John Deere equipment include pesticides, herbicides and fungicides.
- A Material Safety Data Sheet (MSDS) provides specific details on chemical products: physical and health hazards, safety procedures, and emergency response techniques.
- The MSDS should be obtained from the chemical dealer at the time of the chemical purchase.
- Check the MSDS before beginning any job using a hazardous chemical. Know exactly what the risks are and how to do the job safely. Always wear recommended personal protection equipment.

Towing Loads Safely

- Stopping distance increases with speed and weight of towed load. Travel slowly and allow extra time and distance to stop.
- Total towed weight must not exceed limits specified in towing vehicle operator's manual.
- Excessive towed load can cause loss of traction and loss of control on slopes. Reduce towed weight when operating on slopes.
- Never allow children or others in or on towed equipment.
- Use only approved hitches. Tow only with a machine that has a hitch designed for towing. Do not attach towed equipment except at the approved hitch point.

Safety

- Follow the manufacturer's recommendations for weight limits for towed equipment and towing on slopes. Use counterweights or wheel weights as described in the machine operator's manual.
- Do not turn sharply. Use additional caution when turning or operating under adverse surface conditions. Use care when reversing.
- Do not shift to neutral and coast downhill.

Keep Riders Off Towed Attachment

- Keep riders off of a towed attachment.
- Riders on a towed attachment are subject to injury, such as being struck by objects and being thrown off the attachment during sudden starts, stops and turns.
- Riders obstruct the operator's view, resulting in the attachment being used in an unsafe manner.
- Keep riders off of hitch bracket.

Avoid Injury From Drawbar

Before you disconnect an attachment from machine hitch plate:

- Unload attachment.
- Stop attachment on level ground.
- Stop machine engine.
- Lock machine park brake.
- Block attachment wheels.
- Make sure hands, feet or other body parts are not under drawbar.

Practice Safe Maintenance

- Only qualified, trained adults should service this machine.
- Understand service procedure before doing work. Keep area clean and dry.
- Do not operate the engine in a confined space where dangerous carbon monoxide fumes can collect.
- Never lubricate, service or adjust the machine or attachment while it is moving. Keep safety devices in place and in working condition. Keep hardware tight.
- Keep hands, feet, clothing, jewelry, and long hair away from any moving parts, to prevent them from getting caught.
- Lower any attachment completely to the ground or to an existing attachment mechanical stop before servicing the attachment. Disengage all power and stop the engine. Lock park brake and remove the key. Let machine cool.
- Disconnect battery or remove spark plug wire (for gasoline engines) before making any repairs.
- Before servicing machine or attachment, carefully release pressure from any components with stored energy, such as hydraulic components and springs.
- Release hydraulic pressure by lowering attachment or cutting units to the ground or to a mechanical stop and move hydraulic control levers.
- Securely support any machine or attachment elements that must be raised for service work. Use jack stands or lock service latches to support components when needed.
- Never run engine unless park brake is locked.
- Keep all parts in good condition and properly installed. Fix damage immediately. Replace worn or broken parts. Replace all worn or damaged safety and instruction decals.

- Check all hardware at frequent intervals to be sure the equipment is in safe working condition.
- Do not modify machine or safety devices. Unauthorized modifications to the machine or attachment may impair its function and safety.

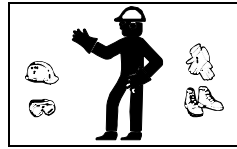

Wear Appropriate Clothing

- Wear close fitting clothing and safety equipment appropriate for the job.
- Certain operating conditions may dictate that the operator and any passenger wear appropriate safety equipment while operating the vehicle. Be prepared for any existing and potential conditions before operating machine.
- Local safety or insurance regulations may require additional safety equipment such as eye protection or a hard hat.
- Always wear substantial footwear and long trousers. Do not operate the equipment when barefoot or wearing open sandals.
- Wear proper clothing and safety equipment while handling chemicals or using the sprayer. Refer to the MSDS for the chemicals being used to be sure the proper personal protection equipment is being used.



Avoid High Pressure Fluids

- Hydraulic hoses and lines can fail due to physical damage, kinks, age, and exposure. Check hoses and lines regularly. Replace damaged hoses and lines.
- Hydraulic fluid connections can loosen due to physical damage and vibration. Check connections regularly. Tighten loose connections.
- Escaping fluid under pressure can penetrate the skin causing serious injury. Avoid the hazard by relieving pressure before disconnecting hydraulic or other lines. Tighten all connections before applying pressure.
- Search for leaks with a piece of cardboard. Protect hands and body from high pressure fluids.
- If an accident occurs, see a doctor immediately. Any fluid injected into the skin must be surgically removed within a few hours or gangrene may result. Doctors unfamiliar with this type of injury should reference a knowledgeable medical source. Such information is available from Deere & Company Medical Department in Moline, Illinois, U.S.A. Information may be obtained in the United States and Canada only by calling 1-800-822-8262.

Dispose of Chemicals Properly

- Proper disposal of excess spray material is very important. If you have excess tank solution, it is best to dilute it with water and apply it to the area you previously treated.
- Never dump solution into a drain or near a lake or stream.
- Chemicals containers should be triple-rinsed, with the rinse water added to the sprayer tank. Do not burn empty chemical containers. Dispose of containers at recycling centers.

Handling Waste Product and Chemicals

Waste products, such as, used oil, fuel, coolant, brake fluid, and batteries, can harm the environment and people:

- Do not use beverage containers for waste fluids - someone may drink from them.
- See your local Recycling Center or authorized dealer to learn how to recycle or get rid of waste products.
- A Material Safety Data Sheet (MSDS) provides specific details on chemical products: physical and health hazards, safety procedures, and

Assembly

emergency response techniques. The seller of the chemical products used with your machine is responsible for providing the MSDS for that product.

Assembly

Identify Parts (25 Gallon Portable Sprayer)

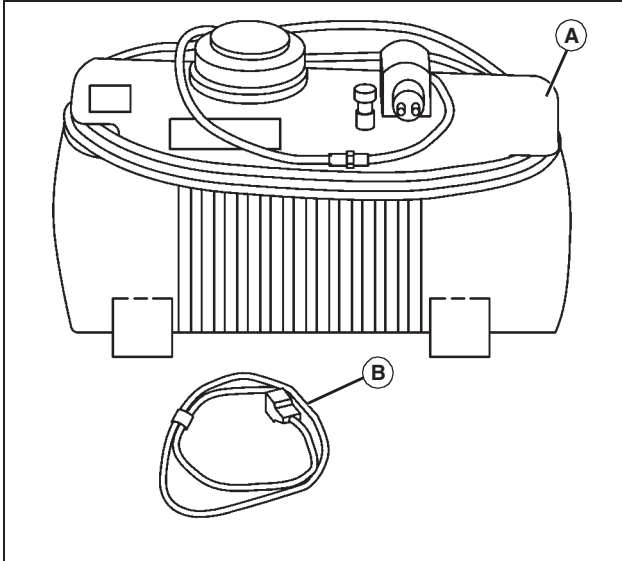

MX34800

A- 25 Gallon Sprayer Base Unit (Tank with pump and hoses attached)

B- Wiring Harness

NOTE: No assembly is required for the 25 Gallon Portable Sprayer.

Identify Parts and Assemble (15 and 25 Gallon - Wheeled Sprayers)

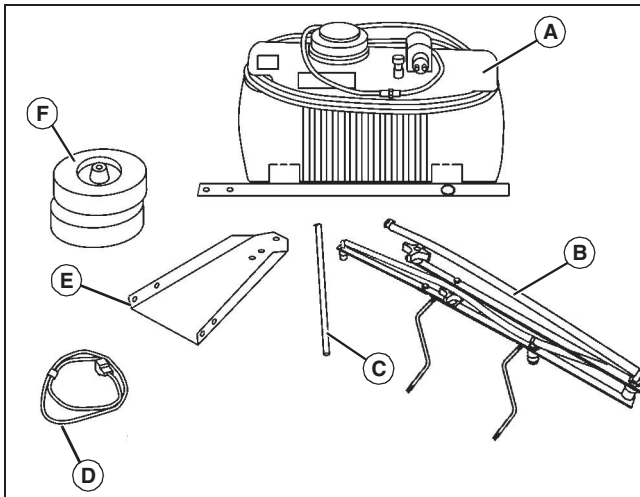

MX38806a

A- Sprayer Base Unit (Tank with pump and hoses attached)

B- Boom Assembly (25 gallon assembly shown)

C- Axle

D- Wiring Harness

E- Hitch Frame

F - (2) Wheels

Bag of Parts

Part Description	15 and 25 Gallon
Hitch Clevis	1
L-Bracket	2
Rod, Boom Support	2
Locking Collar	2
Hitch Pin, 1/2 x 2-1/2 in.	1
Spring Locking Clip	1
Flat Washer	2
Axle Spacer	2
Bolt, Flange, 5/16 x 3/4 in.	6
Nut, Flange, 5/16 in.	6
Nut, 3/8 in.	4
Lockwasher, 3/8 in.	2
Wire Clip	2

Attach Hitch Frame

1. Remove hardware bags and wiring harness from inside tank.

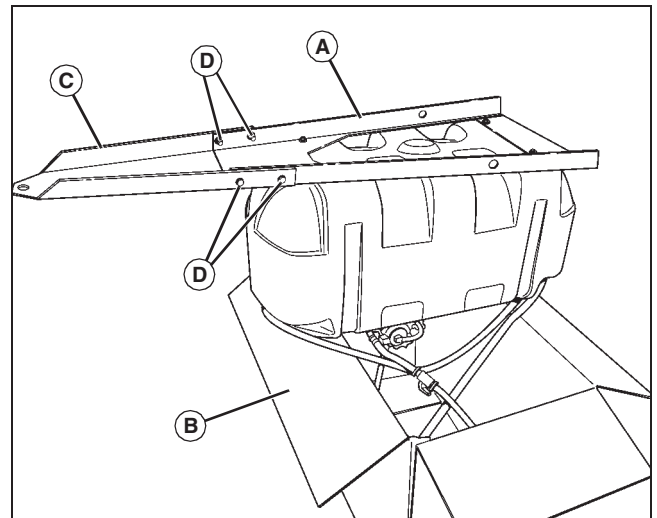

MX38807

2. Place tank and frame assembly, with tank frame (A) on top, onto top of shipping box (B) for installing hitch frame.

NOTE: When installing hardware, always install with nuts to the inside.

3. With tank frame (A) mounted to the inside of the hitch frame (C), align mounting holes on tank frame to mounting holes in hitch frame.

4. Install and tighten hardware (D):

- (4) 5/16 x 5/8 in. Flange Bolts
- (4) 5/16 in. Flange Nuts

Assembly

Install Wheels

NOTE: Install wheels so tire valve stems face to the outside of the sprayer frame.

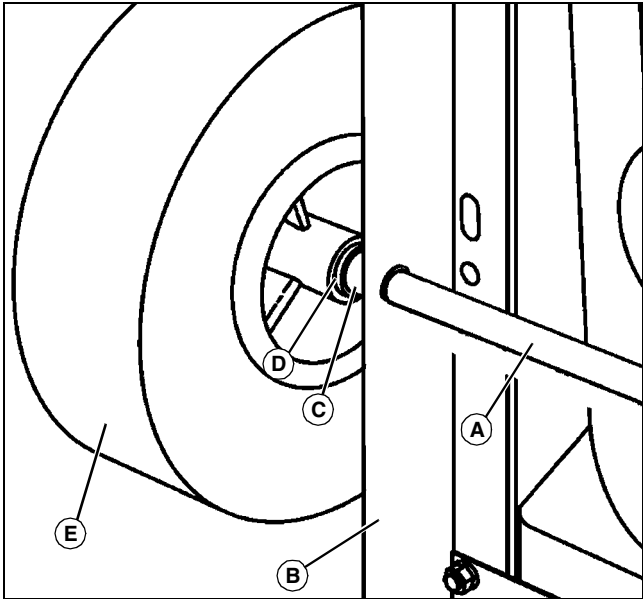

MX38808

1. Install and center axle (A) into rear holes of tank frame (B).
2. Install axle spacer (C) and flat washer (D).
3. Install wheel (E), and then secure outside with locking collar.
4. Repeat for opposite wheel. Wheel hardware:
 - (2) Axle Spacers (C)
 - (2) Flat Washers (D)
 - (2) Locking Collar
5. Tighten locking collars with a hex key wrench.
6. Lubricate wheel bearing grease fittings with recommended grease.
7. Set sprayer on wheels.

Install Hitch Assembly

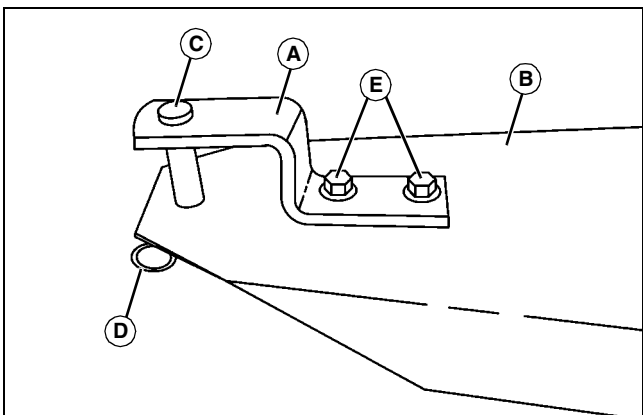

MX34616

1. Install hitch clevis (A) on top of hitch frame (B) with hitch pin (C) and spring locking clip (D).
2. Install and tighten hardware (E):
 - (2) 5/16 x 5/8 in. Flange Bolts

- (2) 5/16 in. Flange Nuts

Install Boom Assembly

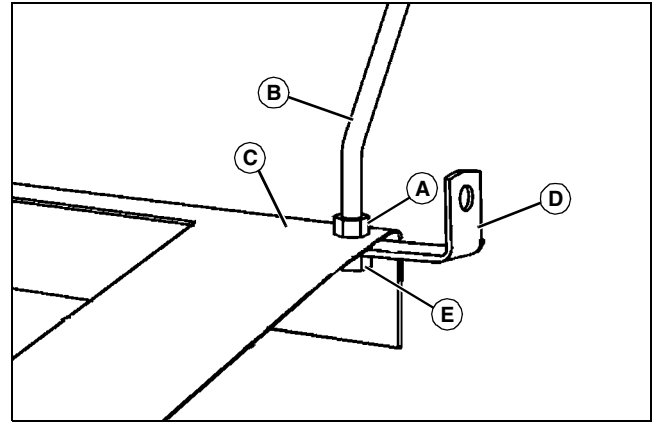

MX38810

1. Install 3/8 in. nut (A) on boom support rod (B). Repeat for opposite side boom support rod.

NOTE: Install L-bracket (D) facing toward rear of assembly and as far rearward as possible, as shown.

Boom assembly should be installed with hose connection tee facing forward.

2. Install entire spray boom and support rods through rear holes in tank frame (C).
3. Install L-bracket (D), 3/8 in. lockwasher, and a second 3/8 in. nut (E). Repeat for opposite side. Boom support hardware:
 - (4) 3/8 in. Nuts
 - (2) 3/8 in. Lockwashers
4. Do not tighten boom hardware until entire boom is in place.

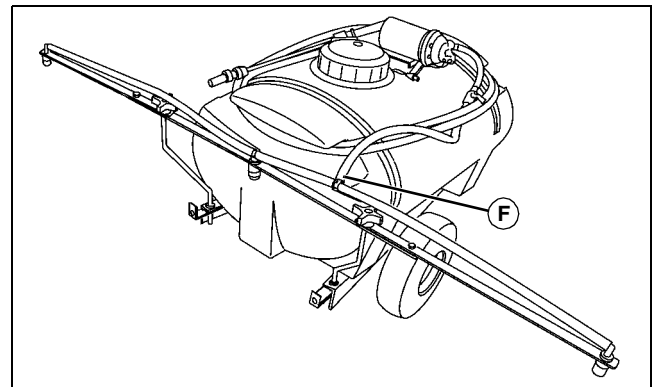

MX38811

Picture Note: 25 gallon shown.

5. Connect tank hose (F) onto tee on boom hose.

Assembly

Level Sprayer

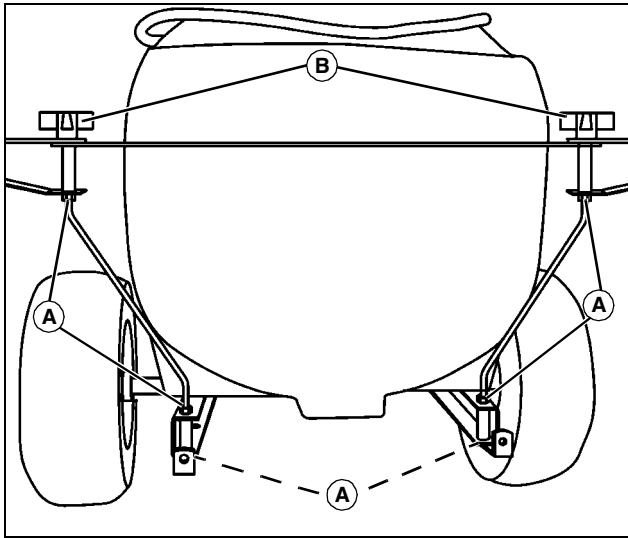

MX34788

Picture Note: 45 gallon shown.

1. Level, straighten and center boom with back of sprayer.
2. Tighten hardware:
 - (6) Nuts, 3/8 in. (A)
 - (2) Locking Knobs (B)

Install Wiring Harness to Battery

IMPORTANT: Avoid damage! To help prevent electrical spark, install red wire to the positive (+) battery terminal first. Then install black wire to negative (-) battery terminal.

To prevent damage to wiring, make sure hood does not close on wires or connectors.

NOTE: Depending on the location of your battery, a wiring harness extension may be required. Part numbers are AM105666 (John Deere) or ST43485 (Agri-Fab). See your John Deere dealer to order parts.

Tractors with a 12 volt receptacle requires a 12 volt plug adapter, part number ST43503 (Superior Tech). See your John Deere dealer to order parts.

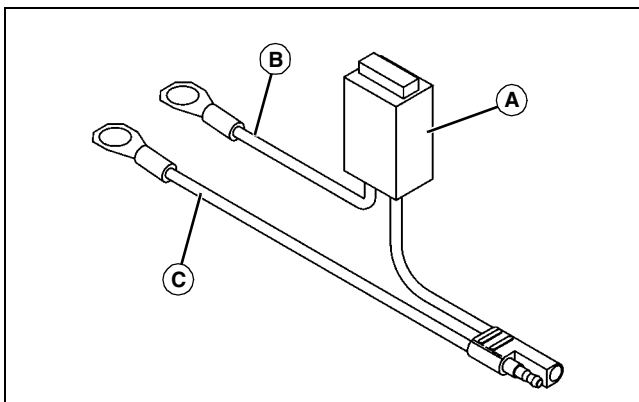

MX34799

1. Fuse holder (A) should contain a 15 A / 32 V fuse. Make sure fuse filament is not broken.
2. Open hood. If battery is mounted low and behind the grille, carefully

unsnap top of grille to provide access to battery terminals.

3. Remove nut from positive (+) battery cable clamp. Install red lead (B) onto clamp bolt. Install and tighten nut completely.
4. Remove nut from negative (-) battery cable clamp. Install black lead (C) onto clamp bolt. Install and tighten nut completely.

Install Wiring Harness Extension (For Machines With Upper Front-Mounted Battery)

NOTE: Wiring Harness Extension is required. See your John Deere dealer to order parts.

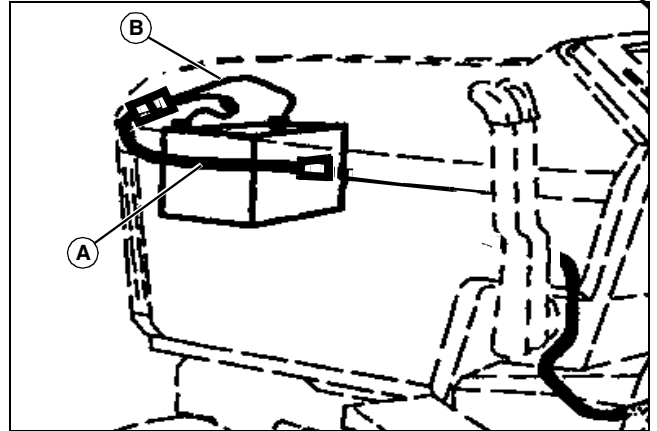

M94107, MIF

Connect wiring harness extension (A) to fused harness (B) at battery. Make sure the harness passes between the left side hood rods.

Install Wiring Harness Extension (For Machines With Lower Front-Mounted Battery)

NOTE: Wiring Harness Extension is required. See your John Deere dealer to order parts.

1. Route wiring harness extension through front frame hole.
2. Connect extension to battery lead plug. Then snap front grille in place.

Install Wire Clips

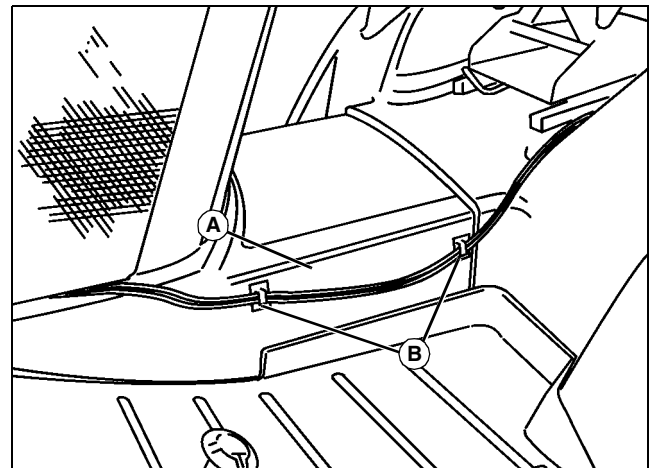

MX34789

1. Clean foot rest side panel (A) at left side of machine with mild detergent or isopropyl alcohol. Dry thoroughly.
2. Attach wire clips (B) to panel. Position the clips as shown so that sprayer main wiring harness will not interfere with deck height adjustment crank, if equipped.

Assembly

Identify Parts and Assemble (45 Gallon - Wheeled Sprayer)

NOTE: Remove bag of parts and wiring harnesses from inside tank.

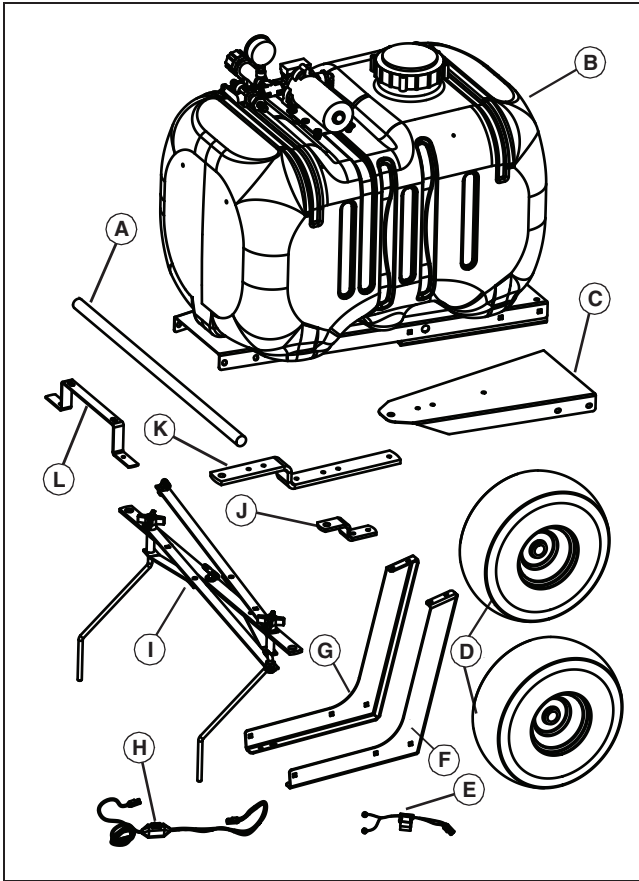

MX50219

- A- Axle Shaft
- B- 45 Gallon Sprayer Base Unit (Tank with pump and hoses attached)
- C- Hitch Frame
- D- Wheels
- E- Wiring Harness, Battery
- F- Left Boom Support (for High Performance Boom on LP39963)
- G- Right Boom Support (for High Performance Boom on LP39963)
- H- Wiring Harness, Switch
- I - Boom Assembly (for LP20485 - HP Booms sold separately)
- J - Hitch Clevis
- K- Drawbar Extension
- L- Hose Tender Bracket

Bag of Parts

Part Description	45 Gallon
Bolt, Flange, 5/16 x 5/8 in	6
Nut, Flange, 5/16 in	12
U-Bolt, Axle, 5/16 in	2
U-Bolt, Square Boom, 5/16 in. (used on high performance boom)	2

Part Description	45 Gallon
Lockwasher, 3/8 in	2
Nut, 3/8 in	4
Shaft Collar	6
Boom Spacer Tube	2
L-Bracket (used on standard boom)	2

Clean Sprayer Tank

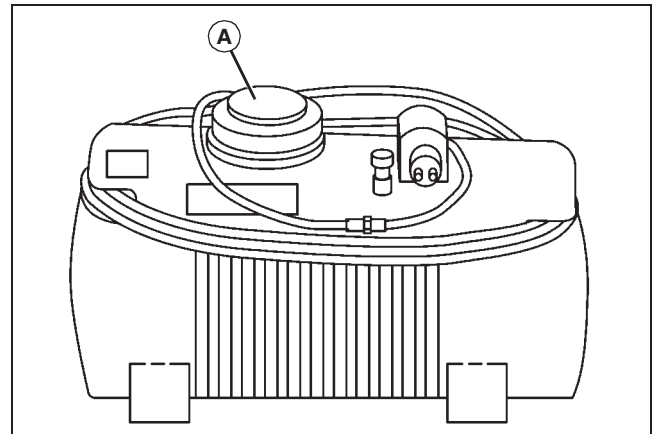

MX34800

1. Remove tank filler cap (A).
2. Remove hardware bags and wiring harness from inside tank.

Attach Hitch Frame

NOTE: When installing hardware, always install with nuts to the inside. Do not tighten any hardware until instructed.

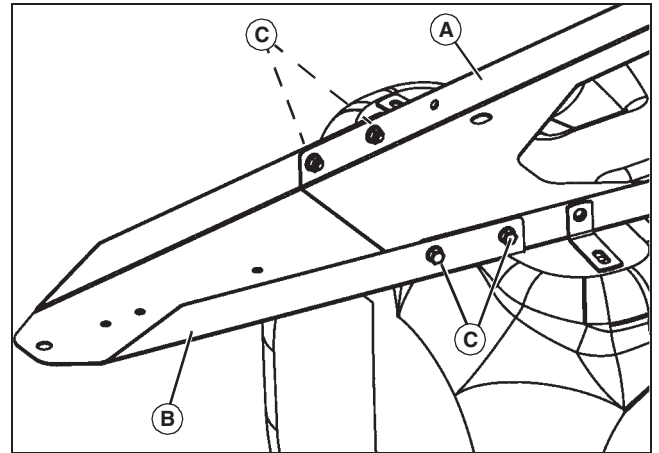

MX50220

1. With tank assembly (A) inverted, attach hitch frame (B) as shown, fastening with four 5/16 x 5/8 in. flange bolts (C) and 5/16 in. flange nuts.

Assembly

Install Hitch Assembly

NOTE: The 45 gallon sprayer hitch can be set up into four different positions. In order for the sprayer to completely empty the tank, the sprayer frame should be as level as possible. Adjust the sprayer drawbar to match the height of the machine hitch.

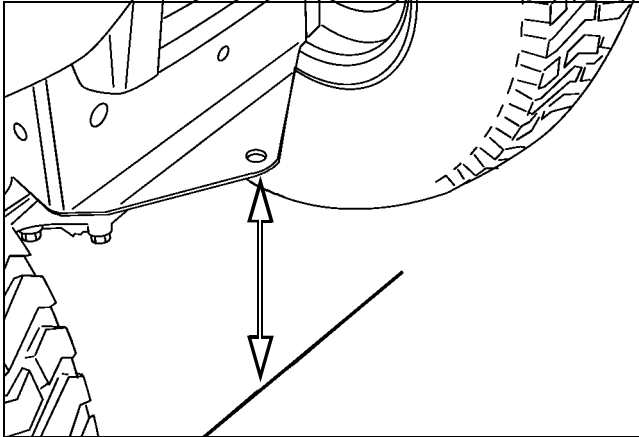

MX34861

1. Measure distance from machine hitch to the ground.

NOTE: Assemble sprayer drawbar to match machine hitch height.

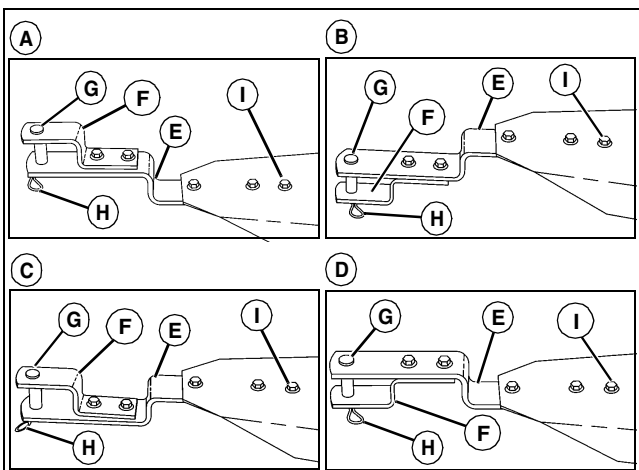

MX34794, MX34796, MX34779, MX34795

- A- Configuration for 30 cm (12 in.) height.
- B- Configuration for 18 cm (7 in.) height.
- C- Configuration for 23 cm (9 in.) height.
- D- Configuration for 27 cm (10.5 in.) height.

2. Install drawbar extension (E) (to bottom side of hitch frame), hitch clevis (F), hitch pin (G), and spring locking pin (H). Install and tighten hardware (I):

- (5) 5/16 x 1 in. Flange Bolts
- (5) 5/16 in. Flange Nuts

Install Axle

NOTE: Before tightening axle hardware, center axle with frame. When hardware is tight, axle should not move.

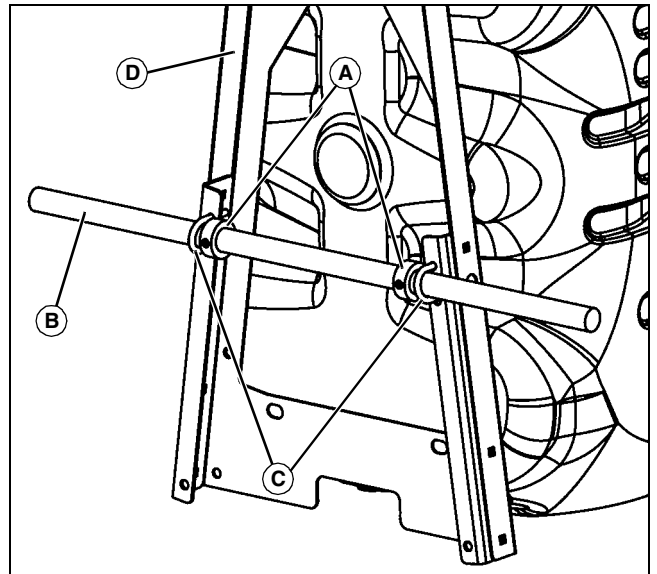

MX50221

1. Slide two locking collars (A) onto center of axle (B).
2. Place axle U-bolts (C) around axle as shown and hold in place with 5/16 in. flange nuts.
3. Center the axle on the tank frame (D) and tighten the flange nuts.
4. Slide the locking collars outward until they contact the metal and tighten the locking collar set screws.

Install Wheels

NOTE: Install wheels so tire valve stems face to the outside of the sprayer frame.

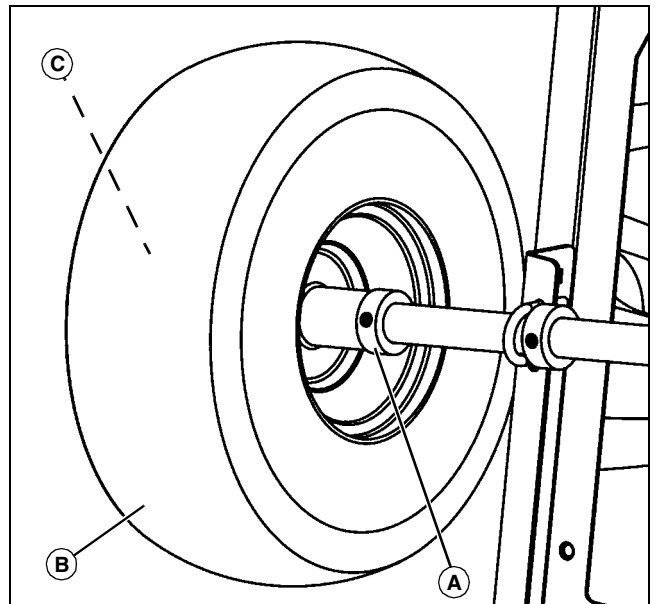

MX50222

1. Slide a shaft collar (A), wheel (B), and another shaft collar (C) on the axle shaft.
2. Make the outside collar flush with the end of the shaft and tighten set screw.

Assembly

3. Push the wheel and inside collar against the outside collar and tighten the set screw.
4. Repeat for opposite wheel.

Install Hose Tender

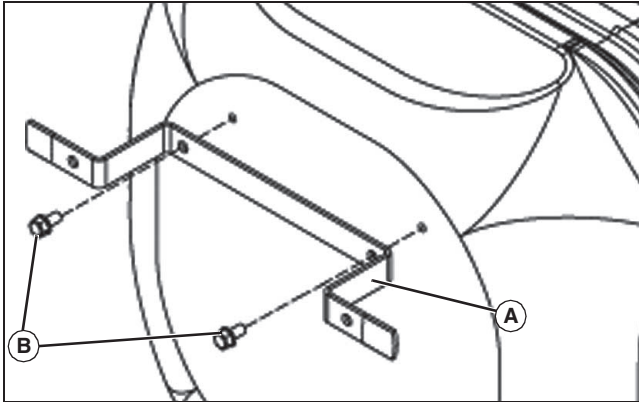

MX27852

1. Install hose tender bracket (A) using two 5/16 x 5/8 in. flange bolts (B).

Install Standard Boom

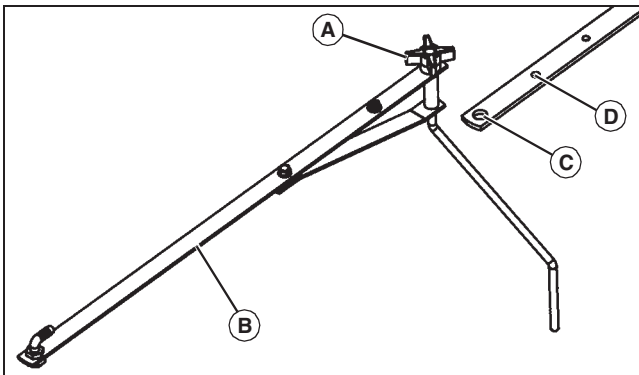

MX50277

1. Remove lock knob (A) and move outer boom (B) from hole (C) to hole (D). Replace lock knob loosely.
2. Repeat on opposite side.

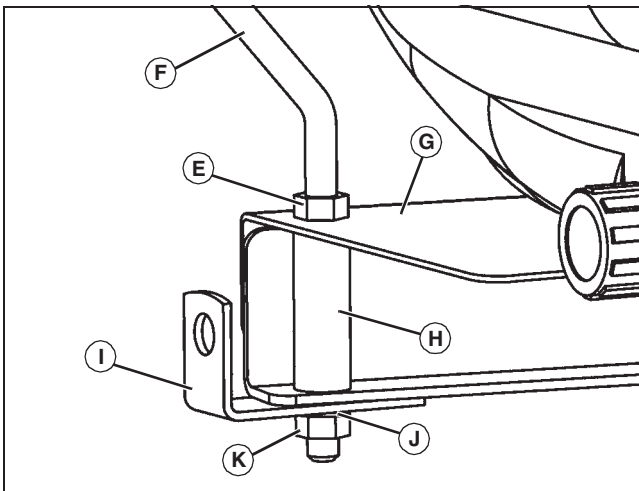

MX50278

3. Install 3/8 in. nut (E) on boom rod (F).
4. Install boom rod (F) through top of frame (G), boom spacer (H), bottom

of frame, L-bracket (I), 3/8 in. lockwasher (J), and 3/8 in. nut (K). Do not tighten hardware.

5. Repeat on opposite side.

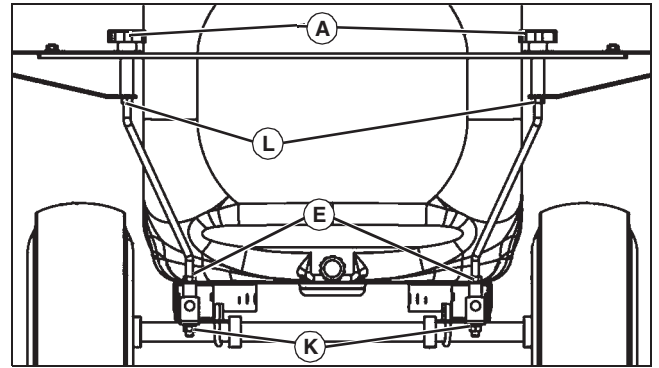

MX50279

6. Level, straighten and center the boom on the back of the sprayer by adjusting the six 3/8 in. nuts (L), (E), and (K), and two lock knobs (A) as necessary. Tighten all hardware.

Install High Performance Boom

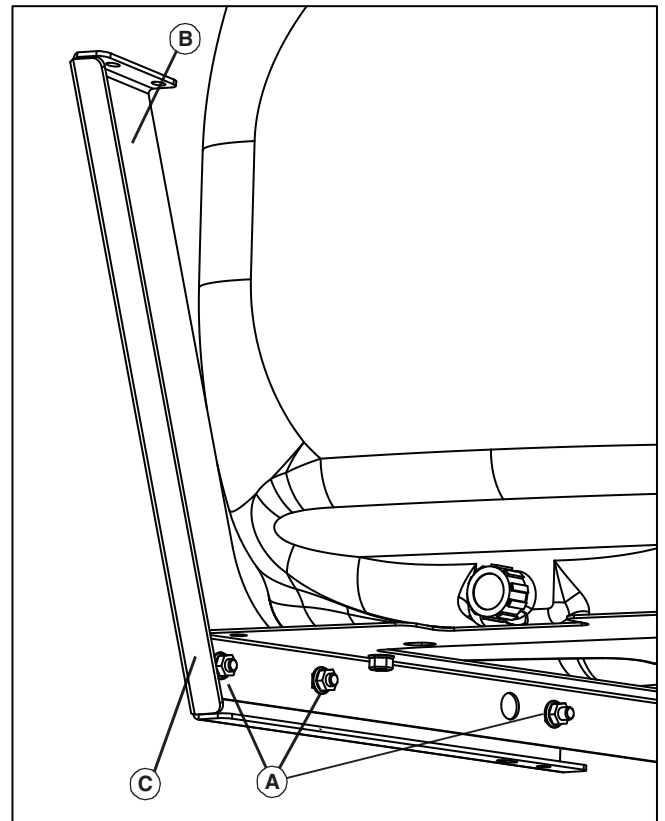

MX50280

1. Install boom supports (B) using three 5/16" x 3/4" carriage bolts and 5/16" flange nuts (A) with with angle (C) facing inward.
2. Repeat on opposite side.

Installing

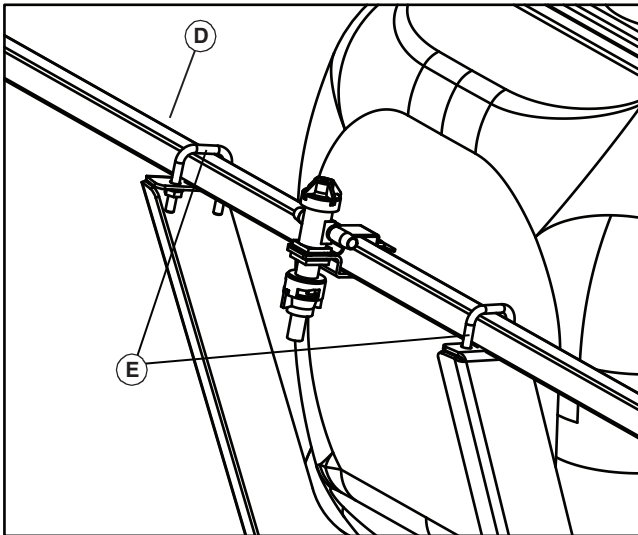

MX50281

3. Mount boom (D) loosely with two square boom U-bolts (E) and four 5/16 in. flange nuts. Center boom on sprayer and tighten nuts.

Install Wiring Harness Extension (For Machines With Upper Front-Mounted Battery)

NOTE: Wiring Harness Extension is required. See your John Deere dealer to order parts.

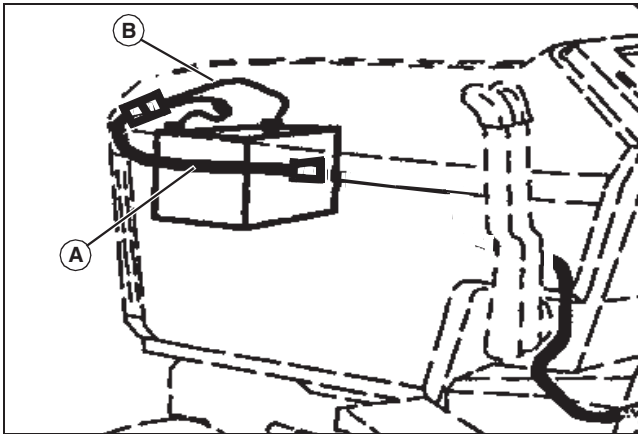

M94107, MIF

Connect wiring harness extension (A) to fused harness (B) at battery. Make sure the harness passes between the left side hood rods.

Install Wiring Harness Extension (For Machines With Lower Front-Mounted Battery)

NOTE: Wiring Harness Extension is required. See your John Deere dealer to order parts.

1. Route wiring harness extension through front frame hole.
2. Connect extension to battery lead plug. Then snap front grille in place.

Install Wire Clips

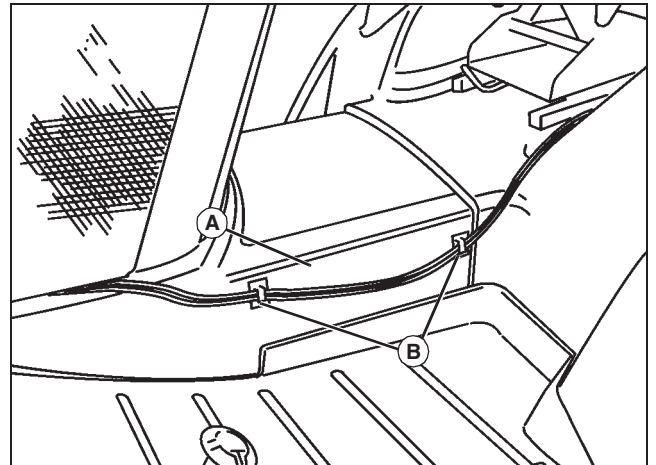

MX34789

1. Clean foot rest side panel (A) at left side of machine with mild detergent or isopropyl alcohol. Dry thoroughly.
2. Attach wire clips (B) to panel. Position the clips as shown so that sprayer main wiring harness will not interfere with deck height adjustment crank, if equipped.

Installing

Attaching Wheeled Sprayer to Machine

NOTE: 45 Gallon Wheeled Sprayer - In order for the sprayer to completely empty the tank, the sprayer frame should be as level as possible. Adjust the sprayer drawbar to match the height of the machine hitch.

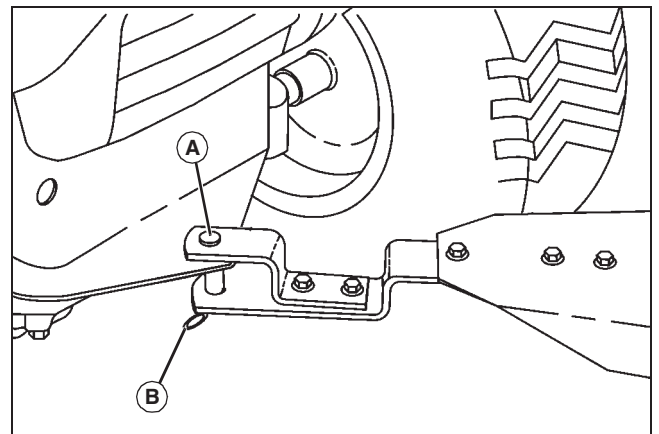

MX34792

Picture Note: 45 Gallon Wheeled Sprayer Shown

1. Put hitch pin (A) into hole in clevis and through hitch.
2. Fasten with spring locking pin (B).

Installing

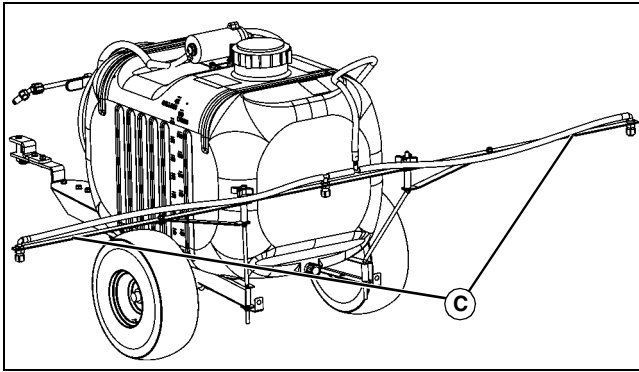

MX42085

Picture Note: 45 Gallon Wheeled Sprayer Shown

3. For 25 and 45 Gallon Sprayers, swing out boom extensions (C) and lock in place.
4. Connect sprayer pump to machine battery.

Attaching Portable Sprayer

Be sure that the carrying vehicle is capable of carrying the 25 gallon portable sprayer fully loaded. When loaded it will weigh about 103 kg (227 lb). It is important that the sprayer be secured properly and that the carrying vehicle can safely carry that load.

Install Wiring Harness (For Machines With Mid-Mounted Battery)

1. Open hood.

NOTE: Switch (A) is not located at center of main wiring harness. The harness plug connector nearest to the switch gets connected to the pump leads.

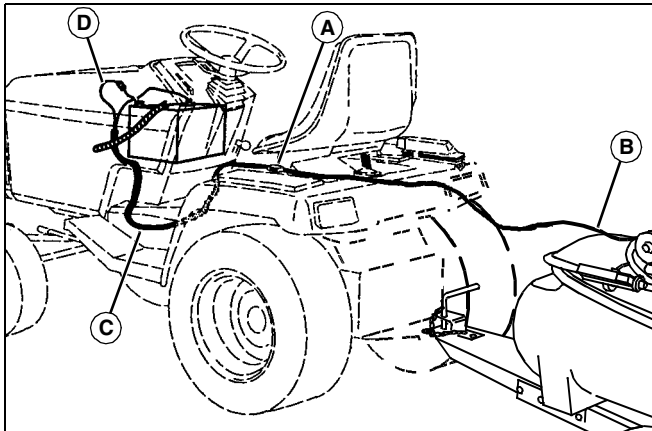

M94107, MIF

Picture Note: Wheeled Sprayer Shown

2. Connect main wiring harness to pump leads (B).
3. Route main harness as shown and clip in place at foot rest side panel (C). On some units route harness on right side of fuel tank filler neck.

IMPORTANT: Avoid damage! Avoid damage to wiring. Make sure hood does not close on wiring harnesses. Keep wiring harnesses away from all moving parts and hot surfaces.

4. Connect other end of main harness to fused battery lead (D).
5. Close hood.

Install Wiring Harness (For Machines With Upper Front-Mounted Battery)

1. Open hood.

NOTE: Switch (A) is not located at center of main wiring harness. The harness wiring connector nearest to the switch gets connected to the pump leads.

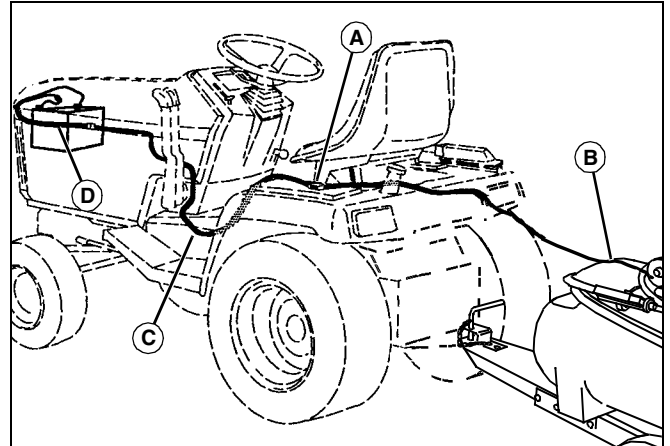

M94107a, MIF

Picture Note: Wheeled Sprayer Shown

2. Connect main wiring harness to pump leads (B).
3. Route main harness as shown. Clip harness in place at foot rest side panel (C). On some units route harness on right side of fuel tank filler neck.

IMPORTANT: Avoid damage! Avoid damage to wiring. Make sure hood does not close on wiring harnesses. Keep wiring harnesses away from all moving parts and hot surfaces.

4. Make sure harness extension (D) passes between the left side hood rods. Connect the main harness to the wiring harness extension.
5. Close hood.

Install Wiring Harness (For Machines With Lower Front-Mounted Battery)

1. Open hood.

Preparing Vehicle

NOTE: Switch (A) is not located at center of main wiring harness. The harness wiring connector nearest to the switch gets connected to the pump leads.

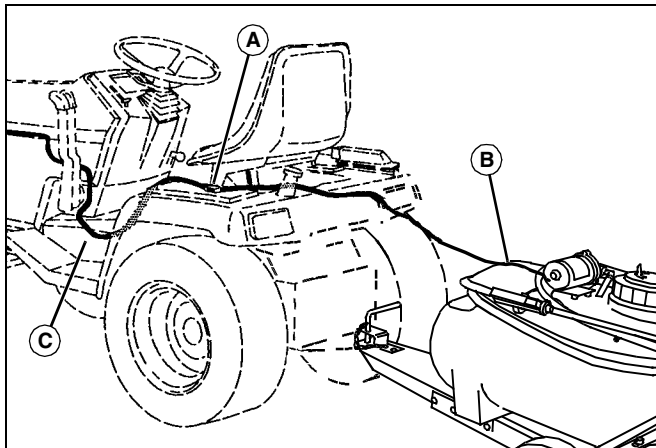

M94107a, MIF

Picture Note: Wheeled Sprayer Shown

2. Connect main wiring harness (B) to pump leads.
3. Route main harness along fender as shown and clip in place at foot rest side panel (C).

IMPORTANT: Avoid damage! Avoid damage to wiring. Make sure hood does not close on wiring harnesses. Keep wiring harnesses away from all moving parts and hot surfaces.

4. For most machines, route main harness along the top of side panel, and connect main harness plug to harness extension.
5. Close hood.

Preparing Vehicle

Machine Requirements (15, 25 and 45 Gallon Wheeled Sprayers)

NOTE: 45 gallon sprayer is not recommended for use with machines smaller than the GT Series.

Sprayer Weight:

- 15 Gallon Sprayer, Filled with liquid is 74 kg (164 lb)
- 25 Gallon Sprayer, Filled with liquid is 115 kg (253 lb)
- 45 Gallon Sprayer, Filled with liquid is 207 kg (456 lb)

IMPORTANT: Avoid damage! No rear suitcase weights or grass bagging attachments should be installed on machine while using sprayers.

Make sure machine tire pressure is correct. (See your machine operator's manual for the correct pressure.)

Machine weights improve stability. Add front weights for better front-end stability and steering. See your John Deere dealer for these weights. Instructions to install will come with the weights.

Your machine requires the following:

- 12-Volt Battery and Alternator
- Wiring Harness Extension: This part is required for all machines with the battery mounted near the front grille. Order this wiring harness from your John Deere dealer.

- Utility Vehicles require an additional 12 V adapter. Order this adapter from your John Deere dealer.

Vehicle Requirements (25 Gallon Portable Sprayer)

Please read the sections on operation and spraying safety in your operator's manual. Pay particular attention to the section dealing with the 12-volt wire harness installation.

You should pay particular attention to what the sprayer will be transported with. Be sure that the unit is capable of carrying the 25 gallon portable sprayer fully loaded. When loaded it will weigh about 103 kg (227 lb), so it is important that the unit be secured properly and that the carrying vehicle can safely carry that load.

Removing and Storing

Removing Sprayer

1. Park machine safely. (See Parking Safely in the Safety section.)
2. Empty the sprayer tank.
3. Disconnect the main wiring harness only. Leave all other harnesses installed on machine.
4. Roll up the main harness and store with sprayer.
5. Remove Sprayer:

Portable Sprayer:

- Remove sprayer from the carrying vehicle.

Wheeled Sprayer:

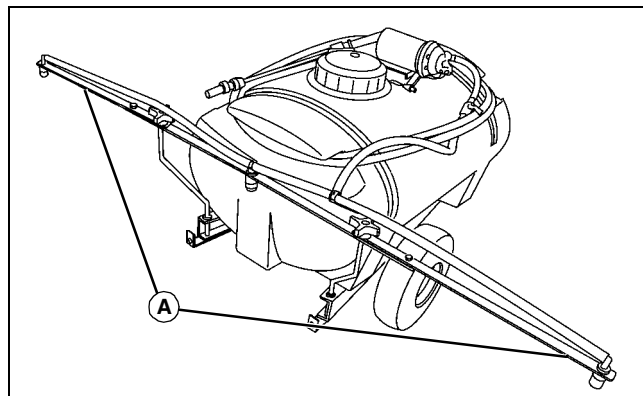

MX34791

Picture Note: 25 Gallon Sprayer Shown

- a. Fold in boom extensions (A).

Removing and Storing

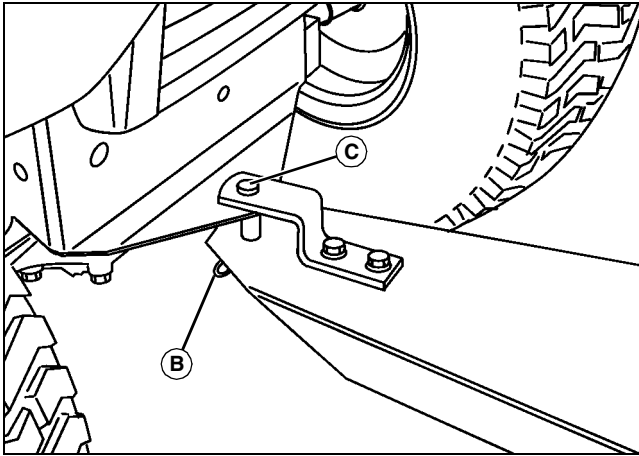

MX34790

- b. Pull spring locking pin (B) out of hitch pin (C). Remove hitch pin (C).
- c. Pull sprayer back from machine.
- d. Put hitch pin in sprayer hitch for storage.

Store Sprayer Safely

1. Clean and drain sprayer tank.

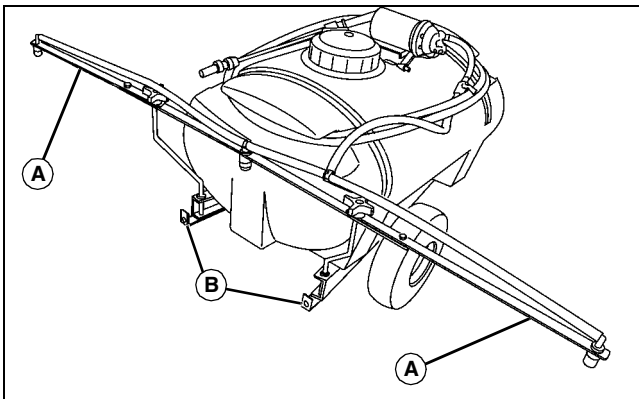

MX34791

Picture Note: 25 Gallon Sprayer Shown

2. If unit is a wheeled sprayer, fold in boom extensions (A).
3. Remove sprayer from transport vehicle.
4. Check sprayer for worn or damaged parts. Replace parts as needed.
5. Tighten loose hardware.
6. Sprayer may be stored on end, with sprayer resting on supports (B).

Operating

Operating

Filling Sprayer Tank



CAUTION: Avoid injury! Chemicals can be dangerous.
Avoid injury to operator or bystanders:

- Read chemical container label for mixing and handling instructions. A Material Safety Data Sheet (MSDS) should be supplied by the chemical dealer and provides proper safety information.
- Wear proper clothing and safety equipment while handling or applying spray chemicals.
- Wear a full covering of clothing, protective goggles and rubber gloves.
- Prohibit all smoking, drinking, and eating around chemicals.
- When filling tank, never allow end of water hose to contact chemical mixture.

1. Clean area around tank filler cap to prevent tank contamination.
2. Remove tank filler cap and fill tank.

Draining and Cleaning Sprayer Tank

IMPORTANT: Avoid damage!

- Proper disposal of excess spray is very important. Dilute it with water and apply it to area previously treated.
- Never dump excess into a storm drain or near a lake or stream.

1. Remove tank drain cap, and empty sprayer tank:
 - Empty remaining solution into an appropriated container for proper disposal.
2. Spray all inside surfaces of tank with low pressure garden hose to remove any remaining solution. Rinse several times to make sure sprayer tank is clean and free of chemicals.
3. Replace drain cap and run fresh, clean water through pump, sprayer wand and all hoses thoroughly.
4. Once the tank is empty, wipe out inside of sprayer tank with a clean cloth or paper towel.

Lifting Portable Sprayer Safely

- Use caution when lifting the portable sprayer to help prevent possible injury.
- When filled with liquid, the 25 gallon portable sprayer weighs 103 kg (227 lb). Empty tank before attempting to lift.

Transporting Portable Sprayer Safely

- Use caution when transporting the portable sprayer to help prevent possible injury.
- When filled with liquid, the 25 gallon portable sprayer weighs 103 kg (227 lb). This extra weight on the back of a vehicle, cart, wheelbarrow, etc. could change the stability of the machine which you chose for transportation.

Transporting Wheeled Sprayer Safely

- Push pump switch to off position.

- Fold boom extensions in their transport position.

Sprayer Weight:

- 15 Gallon Sprayer - Filled with liquid is 74 kg (164 lb)
- 25 Gallon Sprayer - Filled with liquid is 115 kg (253 lb)
- 45 Gallon Sprayer - Filled with liquid is 207 kg (456 lb)

Spraying Tips

- Check sprayer tip height. Adjust sprayer tip height, if needed, before operating.
 - 15 and 25 Gallon Sprayer, 43 cm (17 in.)
 - 45 Gallon Sprayer, 53 cm (21 in.)
- Do not let sprayer run in one spot.
- Do not over spray when you use weed killers.
- Liquid spray material is recommended. Sprayer does not agitate wettable powders.
- Timely applications of a smaller dosage are better than large applications.
- Turn sprayer off during turns to avoid double spraying.
- Fill sprayer where spills cannot harm grass.
- Follow manufacturer's recommendations for application of specific chemicals.
- Stop sprayer when tank is empty.

Adjusting Tip Height and Width

1. Attach sprayer to machine.

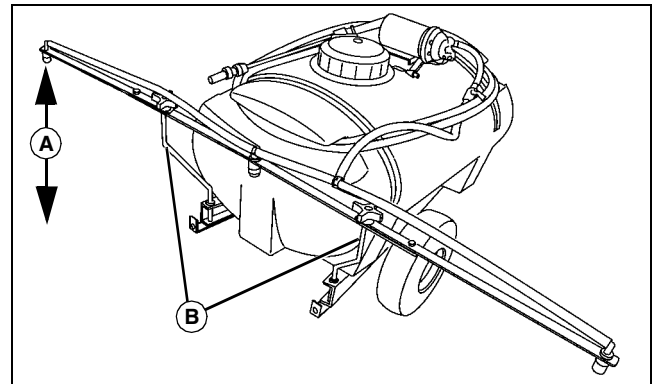

MX34791

Picture Note: 25 Gallon Sprayer Shown

2. Measure from spray tip to ground. Distance to ground (A) should be approximately:

- 15 and 25 Gallon Sprayer - 43 cm (17 in.)
- 45 Gallon Sprayer - 53 cm (21 in.)

If necessary, adjust boom height by raising or lower the boom on the threaded boom supports (B).

Operating

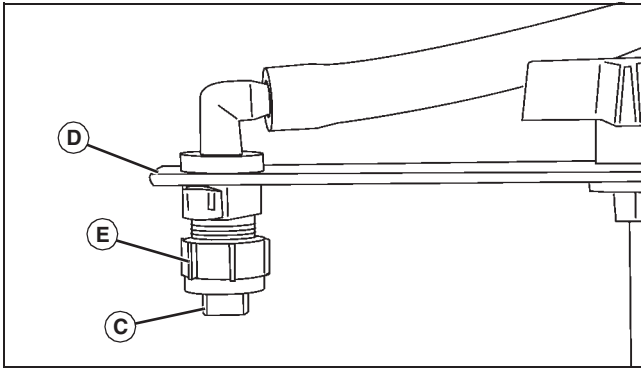

MX34862

3. Check spray tips (C). Tips should be aligned with boom (D) as shown. If necessary, loosen spray tip cap nut (E). Align spray tip (C) and tighten cap nut.

4. Test spray pattern with water on driveway or sidewalk. Each spray tip pattern should spread out to the right and left sides, rather than to the front and back of the boom. There should be some spray overlap between each tip and the spray patterns should be consistent.

Starting and Stopping Sprayer

IMPORTANT: Avoid damage! Operate sprayer with transport vehicle running to avoid discharging the battery.

NOTE: The sprayer pump to battery hookup is a direct electrical connection. Shutting off the transport vehicle does not prevent operation of the sprayer pump. To avoid accidental spraying, disconnect the pump connection before leaving the sprayer.

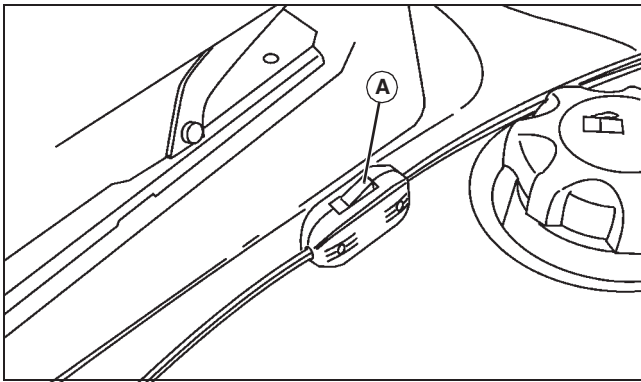

MX34797

Push switch (A) to on or off position to start or stop sprayer.

Sprayer Controls

Pump and valve assemblies are different for each model. Locate model below that corresponds to your unit for correct control definition.

Standard Sprayers

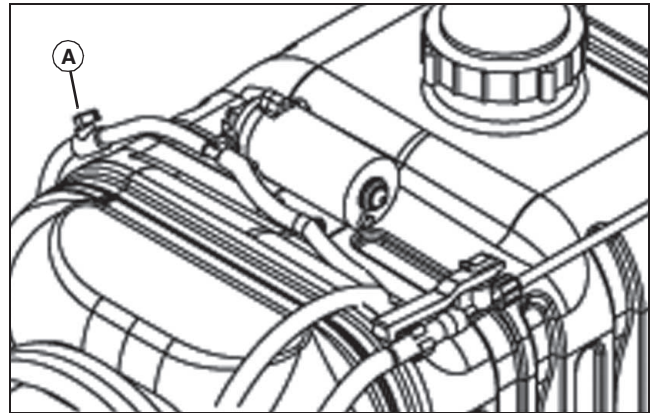

MX27873

Valve (A) is used to control spray to the spray wand or boom:

- In the open position (valve in line with hose) spray will flow to the boom.
- In the closed position (handle perpendicular to hose), spray will flow to spray wand only.

45 Gallon High Performance

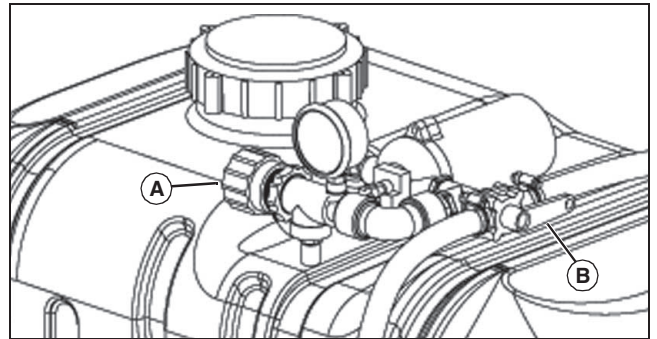

MX27872

Turn knob (A) clockwise to control pressure and recirculation.

Turn knob (A) counter clockwise to recirculate more material to tank and adjust pressure to boom or wand.

Use valve (B) to route spray to spray gun or boom. The direction the handle is pointing, is the direction of flow.

Operating

Operating Spray Wand

NOTE: It is not recommended to use wand while operating the machine. Turn machine on for wand use, but do not maneuver machine unless wand and hose are in normal storage position on the tank.

1. Turn shut-off valve lever perpendicular to hose.

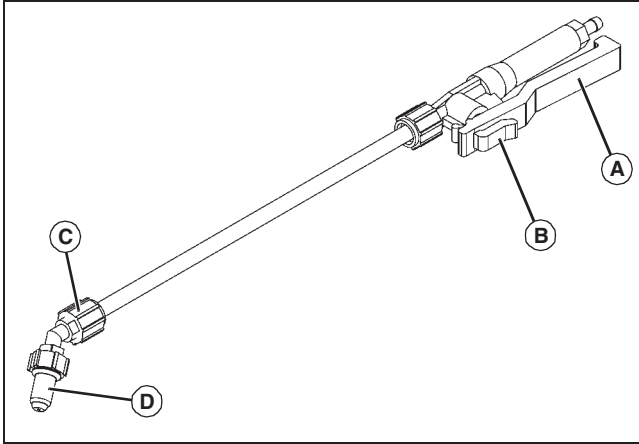

MX45502

2. Squeeze handle (A) to spray.

- Push lock (B) forward to lock handle into the on position.

3. Adjust nozzle:

- Nozzle Angle - Loosen locknut (C). Turn nozzle (D) as desired and tighten locknut.
- Nozzle Spray Pattern - To change spray pattern, tighten or loosen nozzle (D) as desired.

Using High Performance Spray Gun

1. Turn selector lever to spray gun position.

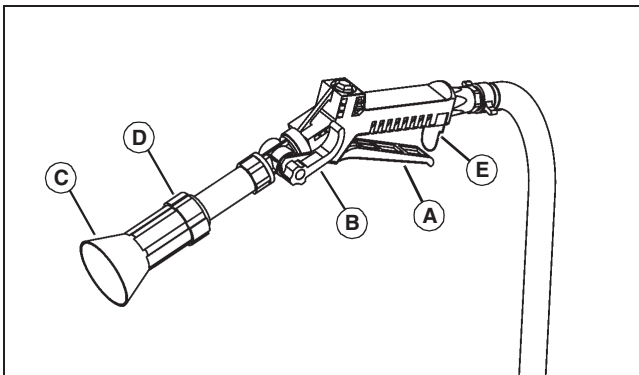

MX43065

2. Squeeze handle (A) to spray.

3. Adjust mist to stream using lever (B).

4. Spray guard (C) can be adjusted by loosening (D) and sliding spray guard to desired position. Spray guard is intended to keep overspray off hands.

5. Flip handle lock (E) forward to lock handle in ON position.

Using Handgun

1. On wheeled sprayers only, turn valve to select handgun operation.
2. Turn the selector lever to the handgun position.

NOTE: Removal of spray tip (A) allows for quick cleaning/rinsing of sprayer tank.

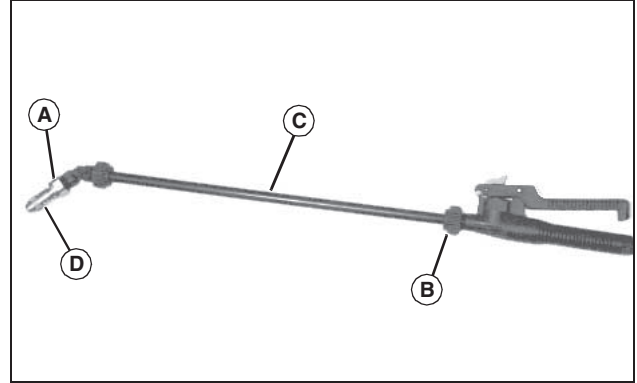

MX13071

3. Adjust nozzle:

- Nozzle Angle – Loosen locknut (B). Turn the nozzle tube (C) to the desired position and tighten the locknut.
- Nozzle Spray Pattern – To change the spray pattern, tighten or loosen nozzle (D) as desired.

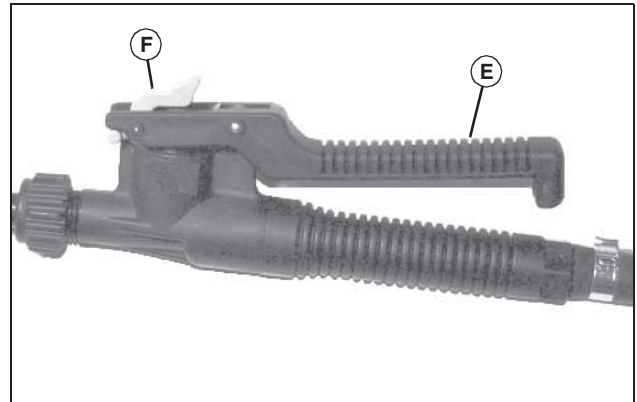

MX13069

4. Squeeze the handle (E) to spray.

5. Push lock (F) forward to lock handle in ON position.

Calibrating the Sprayer

1. Drive vehicle and sprayer (half-full is optimal) across a measured distance at a constant speed. There can be no change in speed while measuring time. Speed should be a comfortable speed for spraying.
2. Have someone measure the amount of time (in seconds) it takes to travel the measured distance.
3. Speed can be found by entering data into the equation: speed (mph) = distance (ft) x 60/time (sec) x 88, or by consulting the following table. It is helpful to note throttle location, gear and/or RPMs in order to maintain accuracy.

Operating

Speed in mph	Time (sec) required to travel a distance of:	
	200 ft	300 ft
1	136	205
1.5	91	136
2	68	102
2.5	55	82
3	45	68
3.5	39	58
4	34	51
4.5	30	45
5	27	41
5.5	25	37
6	23	34
6.5	21	31
7	19	29

NOTE: If using boomless nozzles, use the Boomless Nozzle Chart.

Standard Tow-Behind and Portable Application Information

Although pressure can be adjusted by partially opening the in-line valve, it is recommended that the valve be placed in full open position. The standard boom is equipped with the TF-VP3 tips and sprays approximately 35 psi through the boom when valve is in open position. For calibration purposes, adjust speed for proper coverage.

Measure a 200 or 300 foot distance on a field or a surface similar to where you will be spraying.

Using Calibration Chart

The spray nozzles on your sprayer are TF-VP3, which matches up with the calibration chart. Look at the calibration chart. Use your vehicle speed and desired gallons per acre (gpa), find the pressure (psi) necessary to achieve your gpa. It is important to note that lower pressure settings will result in less spray drift.

Example:

Assume you have found your vehicle speed to be 4 mph, your nozzles are Grey (TF-VP3), and you want to spray 20 gpa. By looking at the chart, you find that you should set the sprayer pressure at 20 psi in order to apply 20 gpa.

NOTE: Optimum spray performance is achieved between 20-25 psi. When shutting off tips use the regulator valve to adjust your boom pressure accordingly.

Adjusting Pressure on Sprayer

NOTE: All calibration needs to be done with clean water.

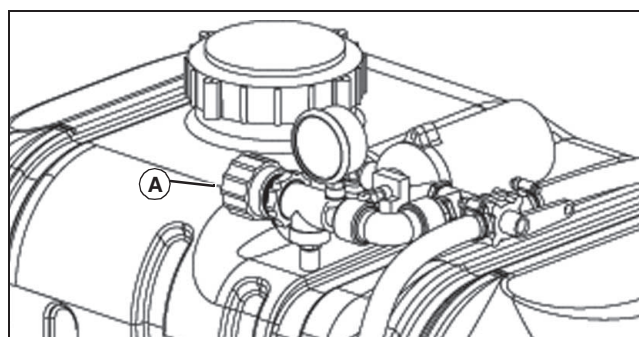

MX27872

HP Sprayer Pressure Setting:

You have found the correct pressure setting, but must now adjust sprayer to that pressure setting. The relief valve (A) controls the sprayers pressure and is located directly beside the pressure gauge. When ready to spray, turn relief valve until necessary pressure is achieved. Sprayer is now calibrated.

Standard Boom

STANDARD BOOM						
Tip Size	PSI	GPM one nozzle	GPA 30 inch spacing			
			2 mph	3 mph	4 mph	5 mph
TF-VP3	10	0.30	29.70	19.80	14.85	11.88
	20	0.42	41.58	27.72	20.79	16.63
	30	0.52	51.48	34.32	25.74	20.59
	40	0.60	59.40	39.60	29.70	23.76

Boomless Nozzles

BOOMLESS CALIBRATION CHART						
PSI	Cap 3 Nozzle GPM	Spray Width (ft)	GPA			
			4 mph	6 mph	8 mph	10 mph
20	3.65	23	12	8	6.1	4.9
30	4.19	25	12.9	8.6	6.5	5.2
40	4.8	28	13.7	9.1	6.8	5.5

150" Folding Boom

150" FOLDING BOOM CALIBRATION CHART						
Tip Size	PSI	GPM one nozzle	GPA 30 inch spacing			
			4 mph	5 mph	6 mph	8 mph
AIC11004	30	0.35	17.3	14	11.5	8.7
	40	0.40	20	16	13.2	9.9
	50	0.45	22	18	14.7	11.1
	60	0.49	24	19.3	16	12.1

Service

Useful Formulas

GPA	=	gallons per acre
GPM	=	gallons per minute
MPH	=	miles per hour
GAL/1000ft ²	=	gallons per 1000 sq. ft.
W	=	nozzle spacing in inches
GPM/per nozzle	=	$\text{gpa} \times \text{mph} \times \text{w} / 5940$
GPM/per nozzle	=	$\text{gal}/1000\text{ft}^2 \times \text{mph} \times \text{w} / 136$
GPA	=	$5940 \times \text{gpm (per nozzle)} / \text{mph} \times \text{w}$
GPA	=	$\text{gallons per 1000 sq. ft.} / .023$
GAL/1000ft ²	=	$136 \times \text{gpm (per nozzle)} / \text{mph} \times \text{w}$

RATES OF FLOW (Calibration of Spray Tips)

GPM	Seconds to collect 1 qt.	GPM	Seconds to collect 1 qt.
0.05	300	0.20	75
0.06	250	0.23	67
0.07	214	0.25	60
0.08	188	0.30	50
0.09	167	0.35	40
0.10	150	0.40	35
0.11	136	0.50	30
0.12	125	0.60	25
0.13	115	0.70	20
0.14	107	0.80	15
0.15	100	0.90	17
0.17	80	1.00	15

NOTICE: Avoid contamination when switching from one chemical to another chemical in the sprayer where contamination must be prevented. Wash with tank cleaner and water throughout the tank, pump, and all hoses. Flush with water two to three times. Herbicides such as 2-4D are hard to remove. Follow instructions on procedures noted on all labels.

Lifting Sprayer Safely

- Use caution when lifting the sprayer to help prevent possible injury.
- Empty tank before attempting to lift.

Transporting Sprayer Safely

- Use caution when transporting the sprayer to help prevent possible injury.
- Push pump switch to OFF position.
- When sprayer is filled with liquid, the extra weight on the back of a machine could change the stability of the machine.

Service

Checking Tire Pressure

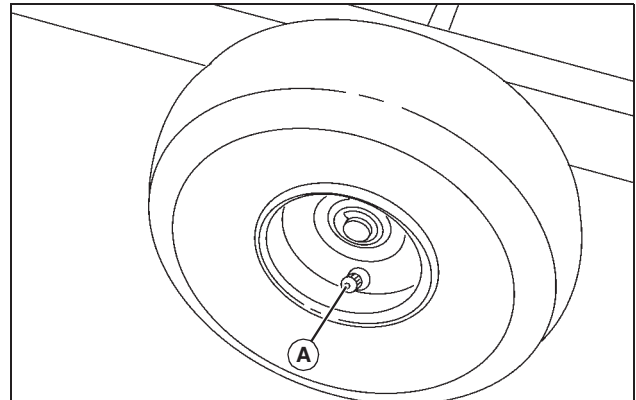

MX34864

Check tire pressure at point (A).

- Tire pressure should be 207 kPa (30 psi).
- Tire Size:
 - 15 and 25 Gallon Sprayer, 4.10 x 3.50 - 4
 - 45 Gallon Sprayer, 15 x 6.00 - 6

Cleaning Spray Nozzle



CAUTION: Avoid injury! Do not put nozzle tip or other sprayer parts to your lips to blow out dirt. Use compressed air or clean water.

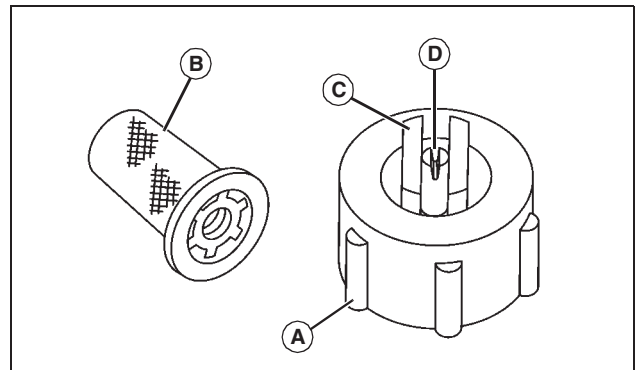

MX34868

1. Remove spray nozzle (A) from sprayer.
 2. Disassemble filter (B) and spray tip (C).
- NOTE:** Do not use a wire to clean opening (D) in spray tip.
3. Wash filter and spray tip in a non-flammable solvent.
 4. Put spray tip in spray nozzle.
 5. Put flat side of filter in spray nozzle.
 6. Install assembly on sprayer and tighten nozzle.

Cleaning Spray Wand Nozzle

NOTE: There are two different styles of nozzles for your sprayer. See below for explanation of each style.

Troubleshooting

CAUTION: Avoid injury! Do not put nozzle tip or other sprayer parts to your lips to blow out dirt. Use compressed air or clean water.

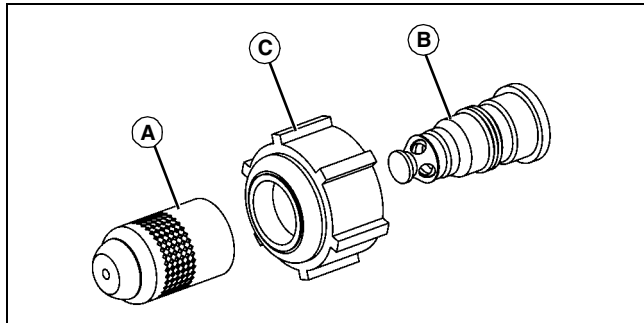

MX50438

1. Remove nozzle (A) from the spray tip (B).
2. Loosen nut (C), and remove the spray tip (B) from the angled fitting on the wand.
3. Wash nozzle (A), and spray tip (B) with liquid detergent and warm water.
4. Inspect O-rings and replace as needed.
5. Slide nut (C) over the spray tip (B), and install on angled fitting on wand.
6. Install nozzle (A) on spray tip (B).

Cleaning Pump Suction Screen

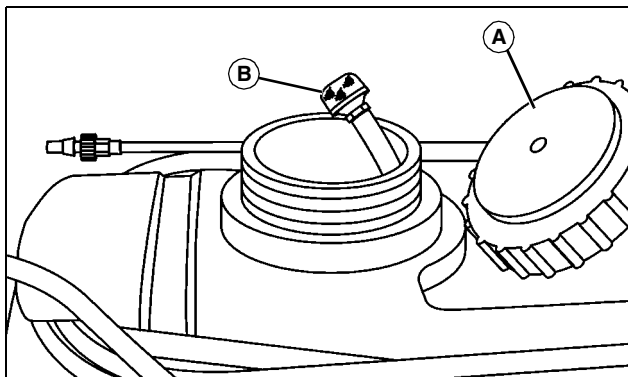

MX34869

1. Remove tank cover (A).
2. Locate suction screen (B) inside sprayer tank.
3. If necessary, unscrew suction screen and clean with liquid detergent and warm water.
4. If suction screen was removed, install on suction hose and position in lowest depression inside tank.
5. Install and tighten tank cover.

Changing Fuse

IMPORTANT: Avoid damage! The electrical system may be damaged if incorrect replacement fuses are used. Replace the bad fuse with a fuse of the same amp rating.

1. Open hood.

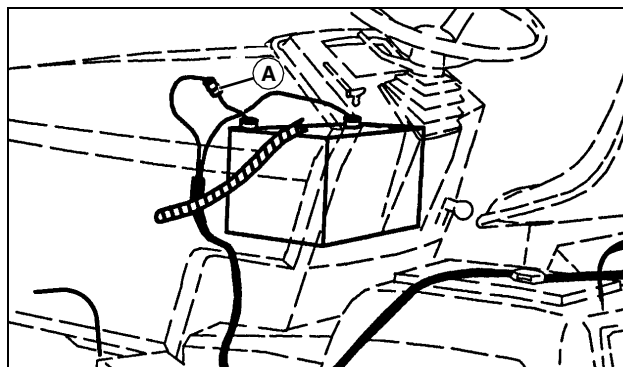

M61159

2. Remove fuse (A).
3. Install new 15 amp fuse.
4. Close hood.

Troubleshooting

Using Troubleshooting Chart

If you are experiencing a problem that is not listed in this chart, see your authorized dealer for service.

When you have checked all the possible causes listed and you are still experiencing the problem, see your authorized dealer.

Using Troubleshooting Chart

IF	CHECK
Pump Loses Suction.	Clean Pump suction screen. Check tank fill level. Fill tank. Clean or replace pump. Check for loose pump fittings.
Pump Capacity Decreased.	Clean pump suction screen. Clean spray nozzle(s). Selection lever is not completely turned on, or is in the OFF position.
Poor Spray Pattern.	Clean spray nozzles. Adjust nozzle height. Align spray tips with boom.
Pump Does Not Work.	Check wiring connections. Check machine battery. Clean debris from pump. Check pump switch. Check pump motor. Check fuse at battery. Adjust pump.

Specifications

Model 15 Gallon Wheeled Sprayer

Tank 57 L (15 gallon)

Getting Quality Service

Pump:
Type Electric Motor and Diaphragm
Manufacturer Deere
Current Draw 7 amp
Fuse 15 amp
System Pressure 689 kPa (100 psi)

Spray Rate 8.3 L/min. (2.2 gal./min.)
Suction Hose Strainer Stainless Steel
Spray Tip Material Plastic

Handgun:
Material Plastic with Brass Tip
Adjustment Fan To Stream

Sprayer:
Nozzle Tip Height 43 cm (17 in.)
Spraying Width 152 cm (60 in.)

Weight:
Empty 20 kg (44 lb)
Full 74 kg (164 lb)

Model 25 Gallon Wheeled and Portable Sprayers

Tank 95 L (25 gallon)

Pump:
Type Electric Motor and Diaphragm
Manufacturer Deere
Current Draw 7 amp
Fuse 15 amp
System Pressure 689 kPa (100 psi)

Spray Rate 8.3 L/min. (2.2 gal./min.)
Suction Hose Strainer Stainless Steel
Spray Tip Material Plastic

Handgun:
Material Plastic with Brass Tip
Adjustment Fan To Stream

Sprayer:
Nozzle Tip Height 43 cm (17 in.)
Spraying Width 229 cm (90 in.)

Weight:
Empty (25 Gallon Wheeled) 24 kg (53 lb)
Empty (25 Gallon Portable) 12 kg (27 lb)
Full (25 Gallon Wheeled) 115 kg (253 lb)
Full (25 Gallon Portable) 103 kg (227 lb)

Model 45 Gallon Wheeled Sprayer

Tank 170 L (45 gallon)

Pump:
Type Electric Motor and Diaphragm
Manufacturer Deere

Current Draw 7 amp
Fuse 15 amp
System Pressure 689 kPa (100 psi)

Spray Rate 8.3 L/min. (2.2 gal./min.)
Suction Hose Strainer Stainless Steel
Spray Tip Material Plastic

Handgun:
Material Plastic with Brass Tip
Adjustment Fan To Stream

Sprayer:
Nozzle Tip Height 53 cm (21 in.)
Spraying Width 305 cm (120 in.)

Weight:
Empty 36.3 kg (80 lb)
Full 207 kg (456 lb)

Model HP 45 Gallon Wheeled Sprayer

Tank 170 L (45 gallon)

Pump:
Type Electric Motor and Diaphragm
Manufacturer Deere
Current Draw 7 amp
Fuse 15 amp
System Pressure * - \$kPa (%\$\$ psi)

Spray Rate 15.1 L/min. (4.0 gal./min.)
Suction Hose Strainer Stainless Steel
Spray Tip Material Plastic

Sprayer Wand:
Material Plastic, Metal Alloy, Brass
Adjustment Single Hand Fan To Stream

Sprayer:
Precision Swath 228 cm (90 in.)
..... 305 cm (120 in.)
..... 381 cm (150 in.)
Boomless Swath 914 cm (360 in.)

Weight:
Empty 38.6 kg (85 lb)
Full 209 kg (460 lb)

Getting Quality Service

John Deere Quality Continues with Quality Service

John Deere provides a process to handle your questions or problems, should they arise, to ensure that product quality continues with quality parts and service support.

Follow the steps below to get answers to any questions you may have about your product.

1. Refer to your attachment and machine operator manuals.

Getting Quality Service

2. In North America or Canada, call John Deere Special Services at 1-800-448-9282 and provide product serial number (if available) and model number.

Standard Sprayer Recirculation Supplement

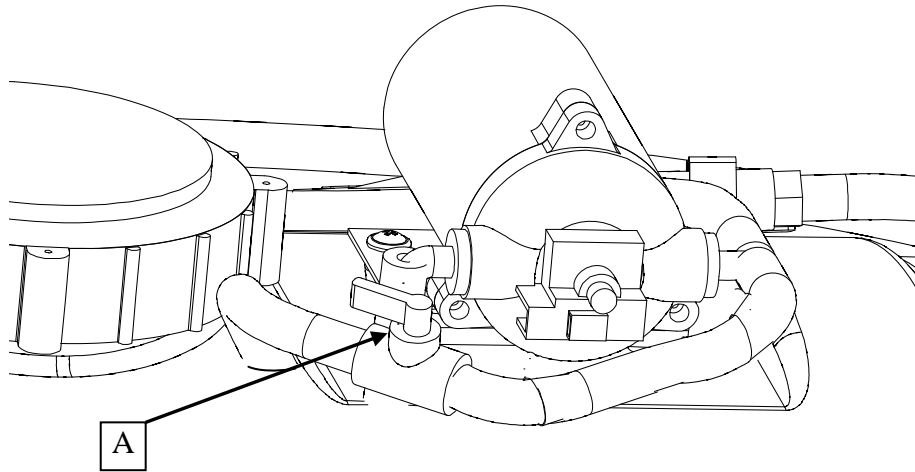

The sprayer is equipped with a recirculation valve (A) to aid in material agitation and pressure control. The location of this valve will vary with the sprayer model. This valve is in the “open” position when the valve handle is in line with the hose (pictured), “closed” when perpendicular to the hose.

Adjusting the recirculation valve between the open/closed positions will affect the pressure coming through the spray wand or boom tips.

- Closed position is full pressure through spray wand or boom.
- It may be helpful to adjust the pressure when spraying with the spray wand to avoid damage to plants from excess pressure.
- If your sprayer is equipped with a boom, this valve should be in the “closed” position when operating the boom.

