



Product Services Information

INSTALLATION INSTRUCTIONS
(English)



IMATCH™ BUSHINGS

Compatibility

All Category I Pins

Parts in Kit

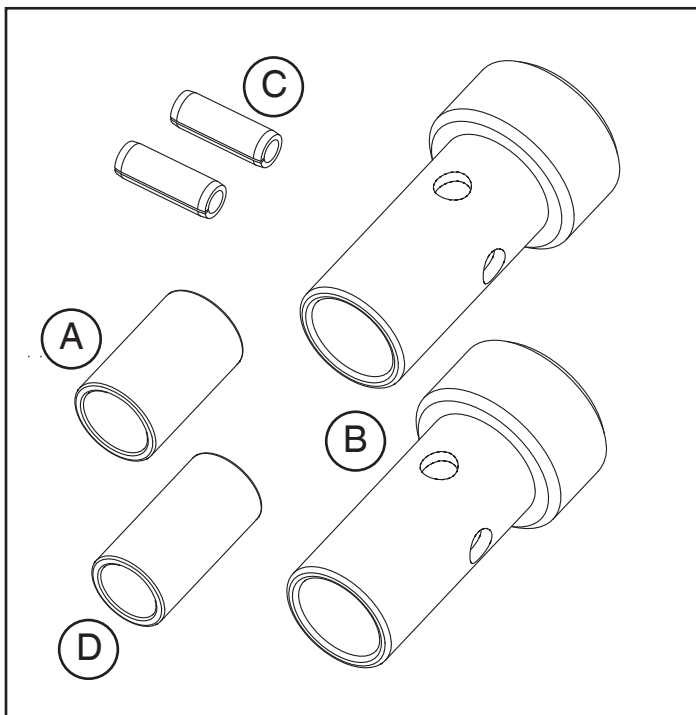

Qty.	Description
1	Top Link Bushing (Cat 2/3) (A)
2	iMatch Shoulder Bushing (B)
2	Roll Pin (C)
1	Top Link Bushing (Cat 1/2) (D)

Installing iMatch Bushings

Category I Application

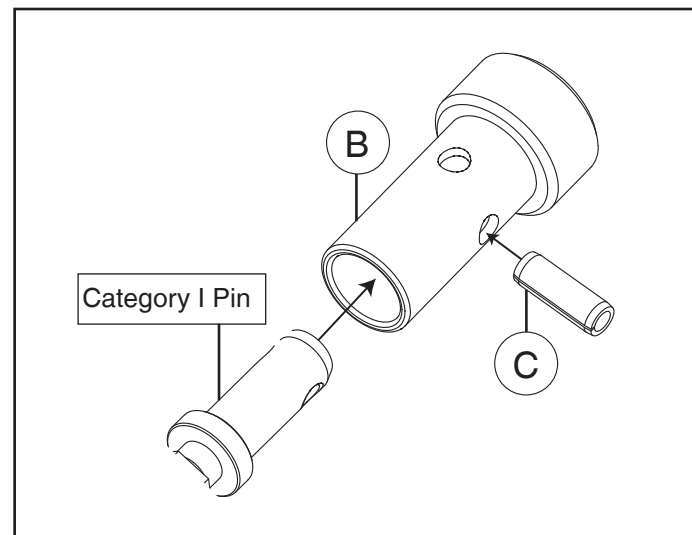

1. Slide iMatch bushing (B) over Category I pin.
2. Line up the hole in the iMatch bushing to the hole in the Category I pin.
3. Insert the roll pin (C). A hammer will be necessary to seat the roll pin.

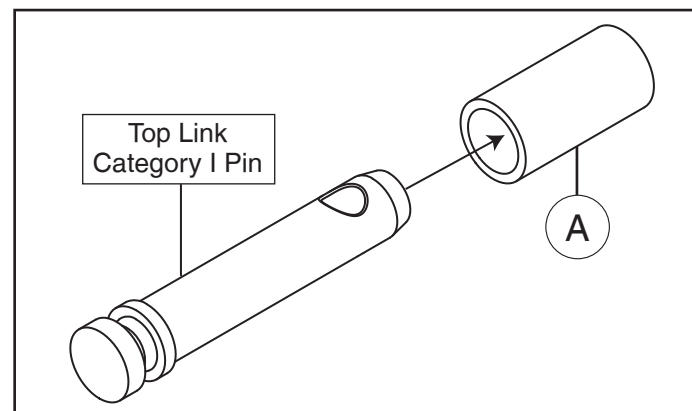

4. Slide top pin bushing (A) on the top link Category 1 pin on your attachment. Use 2nd bushing when needed.