

OPERATOR'S MANUAL

LIQUID SPRAYER

LS2011

LS2015

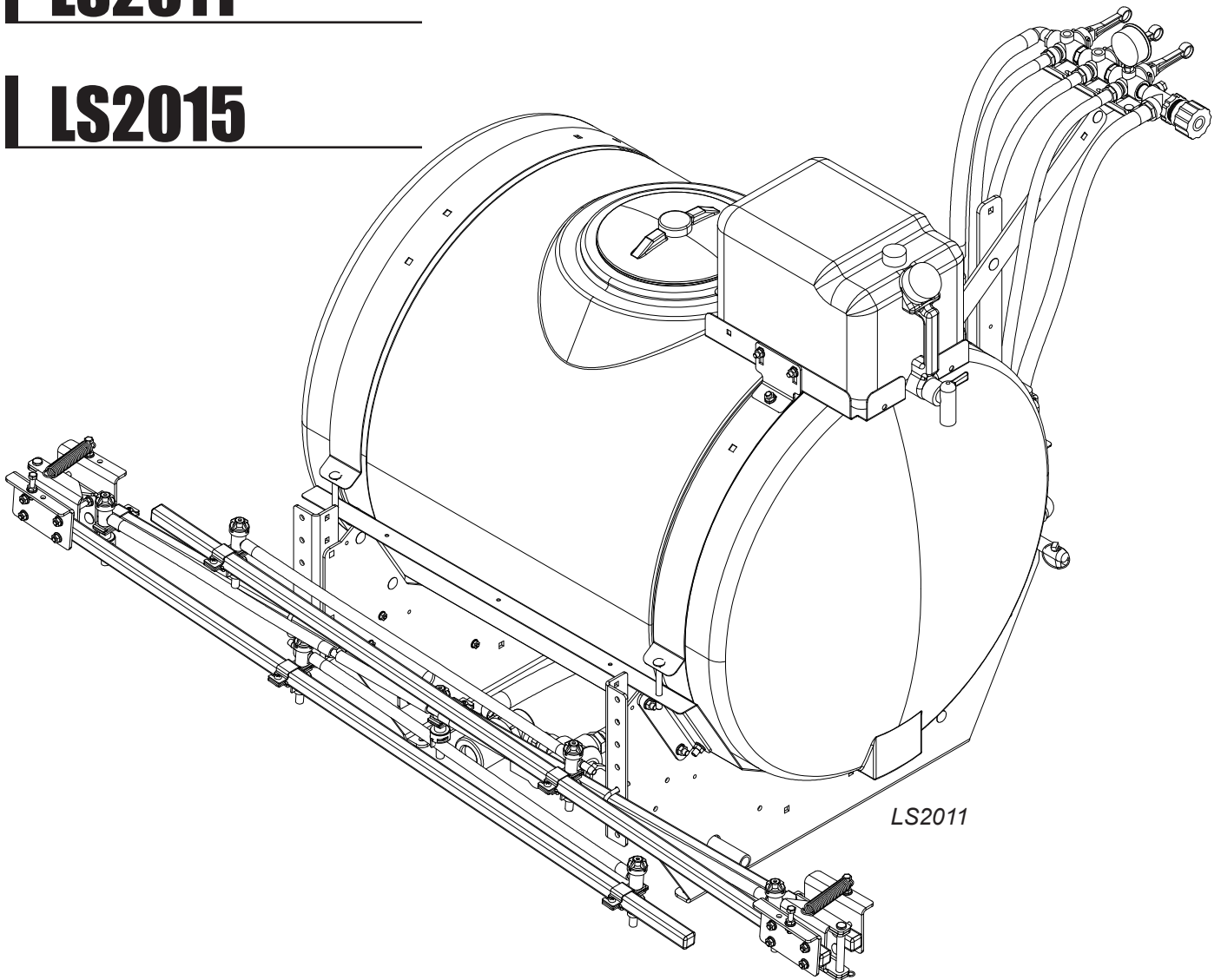

FRONTIER™

TO THE DEALER:

Assembly and proper installation of this product is the responsibility of the Frontier dealer. Read manual instructions and safety rules. Make sure all items on the Dealer's Pre-Delivery and Delivery Check Lists in the Operator's Manual are completed before releasing equipment to the owner.

TO THE OWNER:

Read this manual before operating your Frontier equipment. The information presented will prepare you to do a better and safer job. Keep this manual handy for ready reference. Require all operators to read this manual carefully and become acquainted with all the adjustment and operating procedures before attempting to operate. Replacement manuals can be obtained from your selling dealer.

The equipment you have purchased has been carefully engineered and manufactured to provide dependable and satisfactory use. Like all mechanical products, it will require cleaning and upkeep. Lubricate the unit as specified. Observe all safety information in this manual and safety decals on the equipment.

For service, your authorized Frontier dealer has trained mechanics, genuine Frontier service parts, and the necessary tools and equipment to handle all your needs.

Use only genuine Frontier service parts. Substitute parts will void the warranty and may not meet standards required for safe and satisfactory operation. Record the model number and serial number of your equipment in the spaces provided:

Model: _____ **Date of Purchase:** _____

Serial Number: (see Safety Decal section for location) _____

Provide this information to your dealer to obtain correct repair parts.

Throughout this manual, the term **NOTICE** is used to indicate that failure to observe can cause damage to equipment. The terms **CAUTION**, **WARNING** and **DANGER** are used in conjunction with the Safety-Alert Symbol, (a triangle with an exclamation mark), to indicate the degree of hazard for items of personal safety.



This is the safety alert symbol. It is used to alert you to potential physical injury hazards. Obey all safety messages that follow this symbol to avoid possible injury or death.

 **DANGER**

Indicates a hazardous situation that, if not avoided, will result in death or serious injury.

 **WARNING**

Indicates a hazardous situation that, if not avoided, could result in death or serious injury.

 **CAUTION**

Indicates a hazardous situation that, if not avoided, could result in minor or moderate injury.

**IMPORTANT
or NOTICE**

Is used to address practices not related to physical injury.

NOTE

Indicates helpful information.

TABLE OF CONTENTS

INTRODUCTION	4
SAFETY	5
Safety and Instructional Labels	9
ASSEMBLY	11
INSTALLATION	17
OPERATION	19
SERVICE	24
TROUBLESHOOTING	26
SPECIFICATIONS	27
Tractor Ballasting	31
Parts Diagrams	32
Bolt Torque Chart	64

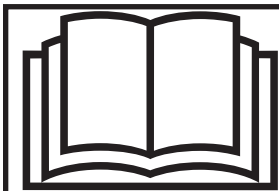

This Operator's Manual should be regarded as part of the machine. Suppliers of both new and second-hand machines must make sure that the manual is provided with the machine.

GENERAL INFORMATION

READ THIS MANUAL carefully to learn how to operate and service your machine correctly. Failure to do so could result in personal injury or equipment damage. This manual and safety signs on your machine may also be available in other languages. (See your Frontier dealer to order.)

The illustrations and data used in this manual were current at the time of printing but, due to possible in-line production changes, your machine may vary slightly in detail. We reserve the right to redesign and change the machines as may be necessary without notification.

THIS MANUAL SHOULD BE CONSIDERED a permanent part of your machine and should remain with the machine when you sell it.

MEASUREMENTS in this manual are given in both metric and customary U.S. unit equivalents. Use only correct replacement parts and fasteners. Metric and inch fasteners may require a specific metric or inch wrench.

RIGHT-HAND AND LEFT-HAND sides are determined by facing in the direction of forward travel.

WARRANTY is provided as part of Frontier's support program for customers who operate and maintain their equipment as described in this manual. The warranty is explained on the warranty certificate or statement which you should have received from your dealer.

This warranty provides you the assurance that Frontier will back its products where defects appear within the warranty period. In some circumstances, Frontier also provides field improvements, often without charge to the customer, even if the product is out of warranty. Should the equipment be abused, or modified to change its performance beyond the original factory specifications, the warranty will become void and field improvements may be denied.

Setting fuel delivery above specifications or otherwise overpowering machines will result in such action.

If you are not the original owner of this machine, it is in your interest to contact your local Frontier dealer to inform them of this unit's serial number. This will help Frontier notify you of any issues or product improvements.

SAFETY

Read Safety in Machine Operator's Manual
Read the general safety operating precautions in your machine operator's manual for additional safety information.

Operate Safely

- Read the machine and attachment operator's manual carefully. Be thoroughly familiar with the controls and the proper use of the equipment. Know how to stop the machine and disengage the controls quickly.
- Do not let children or an untrained person operate machine.
- Make any necessary adjustments before you operate. Never attempt to make any adjustments while the engine is running, unless if recommended in adjustment procedure.
- Take all possible precautions when leaving the machine unattended. Shut off the engine before making any repairs, adjustments, or inspections. Lower the attachment, lock the parking brake, stop the engine, and remove the key.
- Look behind machine before you back up. Back up carefully.
- Do not let anyone, especially children, ride on machine or attachment. Riders are subject to injury such as being struck by foreign objects and being thrown off. Riders may also obstruct the operator's view, resulting in the machine being operated in an unsafe manner.
- Use only attachments and accessories approved by the manufacturer of this product.
- If the machine vibrates abnormally, stop the engine and check immediately for the cause. Vibration is generally a warning of trouble.
- Always refer to the Storage section of the operator's manual for important details if storing this product for a long period of time.
- Keep people and pets out of the work area. Stop machine if anyone enters the area.
- If you hit an object, stop the machine and inspect it. Make repairs before you operate. Keep machine properly maintained and in good working order. Keep all shields and guards in place.
- Always inspect the sprayer completely before and after each use. Before pressurizing the system, check to be sure all fittings and hoses are tightly installed. Be sure guards and shields are in good condition and fastened in place. Make any necessary adjustments before you operate.
- Never use the sprayer during windy conditions.
- Always release pressure in the system before filling, cleaning or servicing the sprayer.
- Do not put nozzle tip or other sprayer parts to your lips to blow out dirt. Use compressed air.
- Install the recommended light kit when this equipment obscures the tractor's tail lamps or stop lamps when transported on the road. Contact your Frontier dealer to obtain the recommended light kit.

Parking Safely

1. Stop vehicle on a level surface, not on a slope.
2. Lock park brake.
3. Lower 3pt attachment to the ground.
4. Stop engine.
5. Remove key.
6. Before you leave the operator's seat, wait for engine and all moving parts to stop.

Mix and Handle Chemicals Safely

- Wear full cover clothing and wear protective goggles and rubber gloves to protect yourself while handling chemicals

- Follow instructions on chemical container labels.
- Open all chemical containers carefully, using proper tools.
- Open, pour, weigh and mix chemicals in a well-ventilated area.
- Reserve all equipment used for the application of chemicals exclusively for that purpose.
- Prohibit all smoking, drinking and eating food in chemical-handling area.
- It is a good practice to take a soapy shower immediately after the using the sprayer to apply chemicals.
- Wash all clothing worn when using chemicals separately in the laundry after spraying is completed.

Read Chemical Container Label

- Chemicals can be dangerous. Improper selection or use can injure persons, animals, plants, soils or other property. Select the right chemical for the job and handle and apply with care.
- Read the instructions, precautions, and warnings on the container label before opening. Use the product strictly according to label directions for specific applications, in the amounts specified, at the times specified and only when needed.
- Keep the container closed tightly except when preparing the mix.
- Do not remove labels from chemical containers. Store all chemicals in their original containers.
- Do not mix chemicals unless stated on the container label.
- Store chemicals when not in use according to the container label.

Handle Chemical Products Safely

- Direct exposure to hazardous chemicals can cause serious injury. Potentially hazardous chemicals used with Frontier equipment include pesticides, herbicides and fungicides.
- A Safety Data Sheet (SDS) provides specific details on chemical products: physical and health hazards, safety procedures, and emergency response techniques.
- The SDS should be obtained from the chemical dealer at the time of the chemical purchase.
- Check the SDS before beginning any job using a hazardous chemical. Know exactly what the risks are and how to do the job safely.
- Always wear recommended personal protection equipment.

Practice Safe Maintenance

- Only qualified, trained adults should service this machine.
- Understand service procedure before doing work. Keep area clean and dry.
- Do not operate the engine in a confined space where dangerous carbon monoxide fumes can collect.
- Never lubricate, service or adjust the machine or attachment while it is moving. Keep safety devices in place and in working condition. Keep hardware tight.
- Keep hands, feet, clothing, jewelry, and long hair away from any moving parts, to prevent them from getting caught.
- Lower any attachment completely to the ground or to an existing attachment mechanical stop before servicing the attachment. Disengage all power and stop the engine. Lock park brake and remove the key. Let machine cool.
- Disconnect battery before making any repairs.

- Before servicing machine or attachment, carefully release pressure from any components with stored energy, such as hydraulic components and springs.
- Release hydraulic pressure by lowering attachment or cutting units to the ground or to a mechanical stop and move hydraulic control levers.
- Securely support any machine or attachment elements that must be raised for service work. Use jack stands or lock service latches to support components when needed.
- Never run engine unless park brake is locked.
- Keep all parts in good condition and properly installed. Fix damage immediately. Replace worn or broken parts. Replace all worn or damaged safety and instruction decals.
- Check all hardware at frequent intervals to be sure the equipment is in safe working condition.
- Do not modify machine or safety devices. Unauthorized modifications to the machine or attachment may impair its function and safety.

Transportation

- Use additional caution and reduce speed when under adverse surface conditions, turning, or on inclines.
- Do not operate or transport on steep slopes.
- Do not operate or transport equipment while under the influence of alcohol or drugs.
- Always comply with all state and local lighting and marking requirements.
- Install the recommended light kit when this equipment obscures the tractor's tail lamps or stop lamps when transported on the road. Contact your Frontier dealer to obtain the recommended light kit.

Storage

- Block equipment securely for storage.

- Keep children and bystanders away from storage area.



Wear Appropriate Clothing

- Wear close fitting clothing and safety equipment appropriate for the job.
- Certain operating conditions may dictate that the operator and any passenger wear appropriate safety equipment while operating the vehicle. Be prepared for any existing and potential conditions before operating machine.
- Local safety or insurance regulations may require additional safety equipment such as eye protection or a hard hat.
- Always wear substantial footwear and long-legged pants. Do not operate the equipment when barefoot or wearing open sandals.
- Wear proper clothing and safety equipment while handling chemicals or using the sprayer. Refer to the SDS for the chemicals being used to be sure the proper personal protection equipment is being used.

Dispose of Chemicals Properly

- Proper disposal of excess spray material is very important. If you have excess tank solution, it is best to dilute it with water and apply it to the area you previously treated.
- Never dump solution into a drain or near a lake or stream.
- Chemicals containers should be triple-rinsed, with the rinse water added to the sprayer tank. Do not burn empty chemical containers. Dispose of containers at recycling centers.

Handling Waste Product and Chemicals

Waste products, such as, used oil, fuel, coolant, brake fluid, and batteries, can harm the environment and people:

- Do not use beverage containers for waste fluids someone may drink from them.
- See your local Recycling Center or authorized dealer to learn how to recycle or get rid of waste products.
- A Safety Data Sheet (SDS) provides specific details on chemical products: physical and health hazards, safety procedures, and emergency response techniques. The seller of the chemical products used with your machine is responsible for providing the SDS for that product.



SAFETY AND INSTRUCTIONAL LABELS
ATTENTION! BECOME ALERT! YOUR SAFETY IS INVOLVED!
 Replace Damaged or Missing Labels Immediately!



1 - PN 5CS50910

CAUTION

1. Read and understand the Operator's Manual before using.
2. Tractor cab may not provide sufficient protection. See Tractor's Operator's Manual.
3. Stay away from chemicals, spray, and drift.
4. Before servicing or filling sprayer, lower all equipment to the ground, set the park brake, stop the engine, and remove the key.
5. Keep hands, feet, hair, and clothing away from moving parts.
6. Clear the area of bystanders before extending or folding booms.
7. Do not allow riders.
8. Keep others away.

ST50910

2 - PN 5CS50927

WARNING



To avoid injury from chemical hazards due to eye and skin contact, inhalation, and ingestion, wear personal protective equipment. Read and follow chemical manufacturer's labels and instructions.

ST50927

3 - PN 5CS4894

NOTICE

If used or transported on roadway, contact your dealer to obtain necessary lighting kit.

ST48594

4 - Serial Number Tag

FRONTIER

Serial Number
 XXXXXXXXXXXXXXXXXXXX



110 GALLON LIQUID SPRAYER MODEL# LS2011

MADE IN USA
 DEERE & COMPANY, MOLINE, ILLINOIS, USA

5 - 5CS50930 (LS2011) / 5CS50931 (LS2015)

LS2011 110 GALLON LIQUID SPRAYER

Mfg Date: MM/DD/YYYY
 Mass (Empty): 271 - 450 Lbs (123 - 204 Kg)
 Mass (Laden): 1229 - 1450 Lbs (557 - 658 Kg)
 Tank Volume: 110 Gal (416 L)
 Max Working Pressure: 150 psi (10.3 Bar)
 Nominal Rotating Frequency: 540 RPM

ST50930

6 - PN 5CS50909

WARNING

Water for rinse/wash purposes only. Do not drink from this container. Container may become contaminated by sprayer chemicals. Fill with clean rinse water only.

ST50909



SAFETY AND INSTRUCTIONAL LABELS
ATTENTION! BECOME ALERT! YOUR SAFETY IS INVOLVED!
Replace Damaged or Missing Labels Immediately!



(Safety Decals continued from previous page)

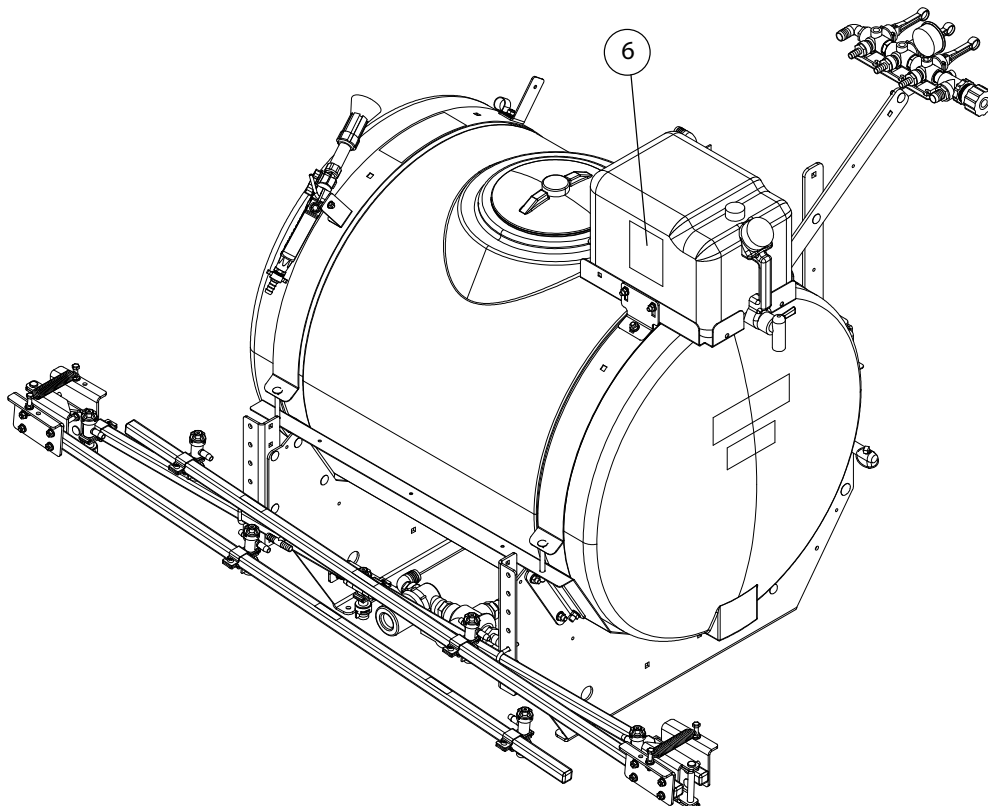
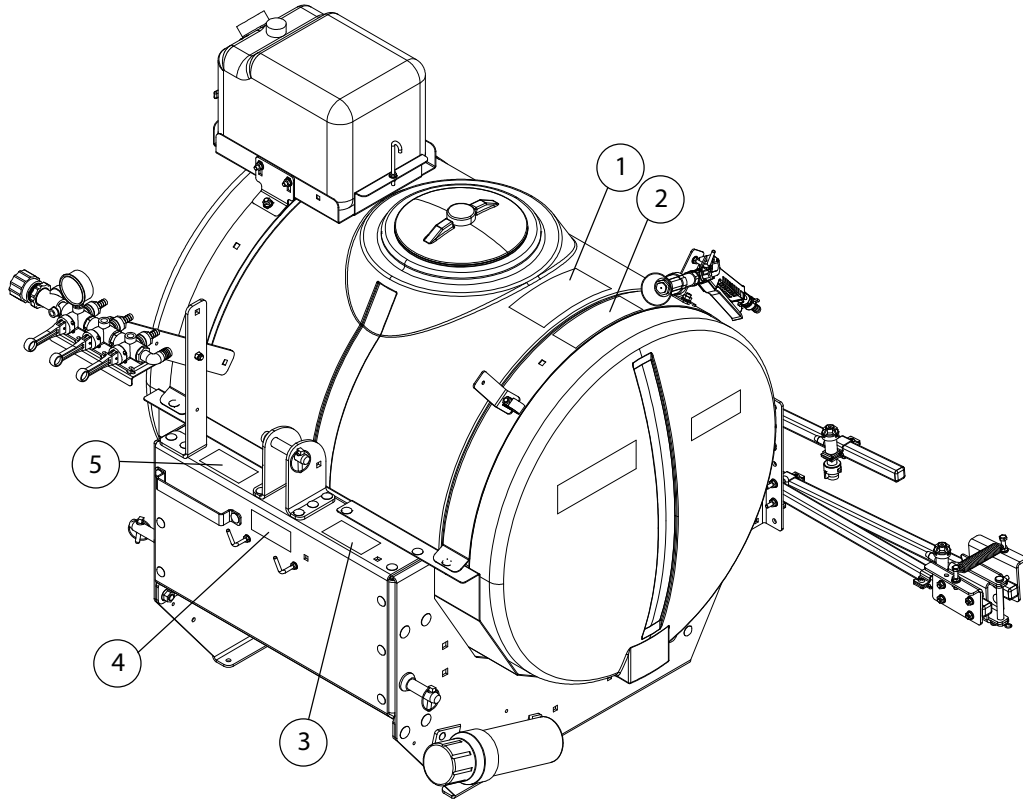

ASSEMBLY

Dealer Set-Up Instructions

Assembly of this equipment is the responsibility of the Frontier dealer. It should be delivered to the owner completely assembled and adjusted for normal operating conditions.

In most cases the sprayer will be shipped completely assembled with the only assembly being the boom, the fresh water tank and 100 ft hose reel kit. The on-highway light kit can be added to the sprayer at a later time if desired.

Parts in Kit

Description	Qty.
Sprayer Assembly	1
Boom	1
Hardware Kit	1
Fresh Water Tank	1

Hardware Kit

Description	Qty.
Hose Clamp 1/2 in.	3
U-Bolt, 5/16 in. Square	3
Nut, 5/16 in.	6
Flange Bolt 5/16 in. x 3/4 in. (24 ft and 30 ft Boom Only)	8

Remove Sprayer from Shipping Pallet

1. Remove plastic stretch wrap from sprayer and boom.
2. Remove hardware that used to secure sprayer to pallet and remove sprayer from pallet.
3. If options are supplied, remove these from the pallet.
4. Remove nut (A) to detach PTO pump from sprayer and discard nut and bolt.

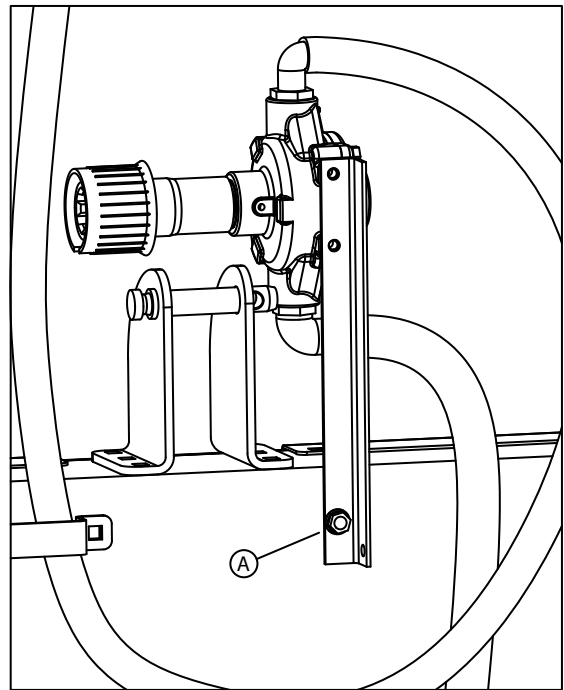

Install Fresh Water Tank

1. Install Spigot (A) onto Fresh Water Tank (B). Spigot is located inside of tank for shipping.

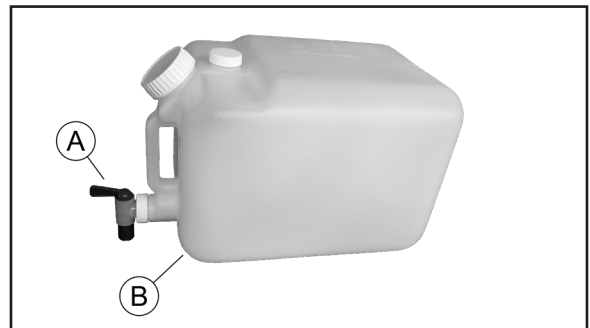

2. Place Fresh Water Tank on Bracket (C) and secure by routing Strap (D) over top of tank to J-Hook (E).

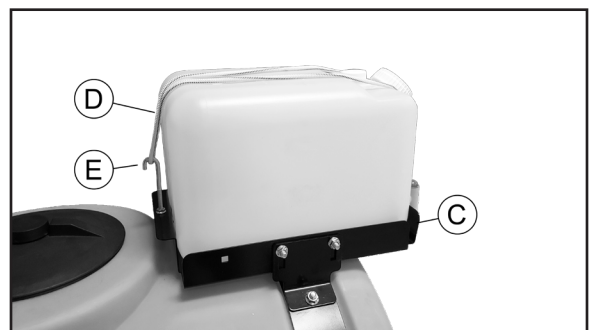

Control Valve Assembly

Control valve assembly is factory installed in a vertical position to protect it during shipping. This assembly should be re-positioned for optimal use and accessibility following these steps.

1. Carefully loosen bolts (A).

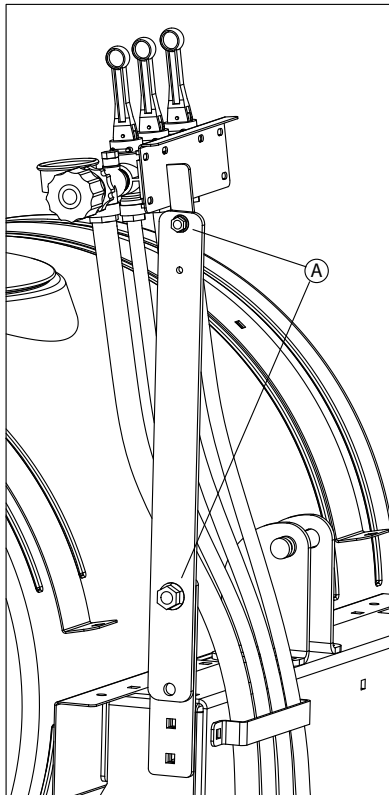

2. Rotate control valve to height required and place bottom bolt in appropriate hole (B) for desired position of valve. Tighten bolts.

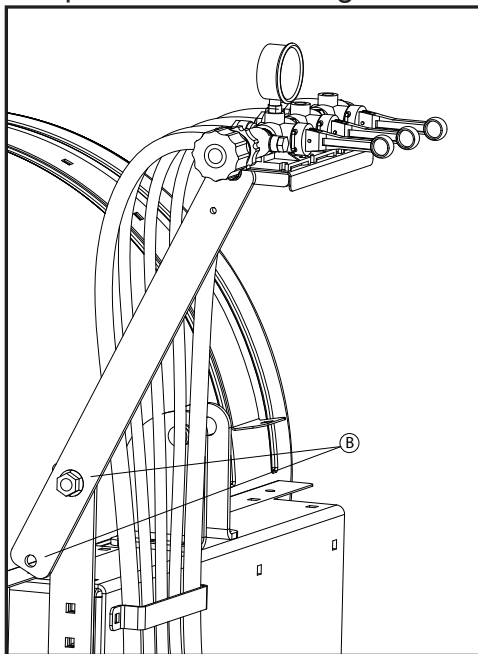

Install Boom (18 ft and Boomless)

1. Center the boom on the rear of the main sprayer.
2. Locate the (2) main upright support brackets with holes.
3. Bolt the boom to the upright support brackets using two 5/16 inch square U-bolts (A) and four 5/16 inch flange nuts.

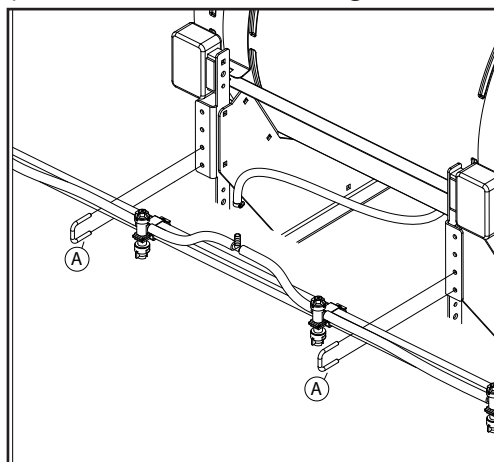

Install Boom (24 ft and 30 ft)

1. Center the boom on the rear of the main sprayer.
2. Locate the (2) main upright support brackets with holes.
3. Bolt the boom to the upright support brackets using two 5/16 inch square U-bolts (A) and four 5/16 inch flange nuts.
4. Fasten hinge brace to support brackets using two 5/16 inch 3/4 inch flange bolts (B) and two 5/16 inch flange nuts.

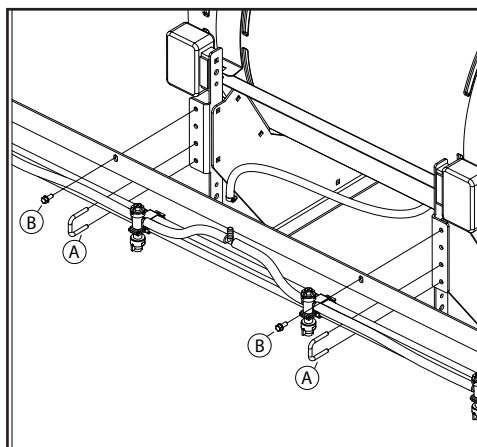

5. Secure side boom hinge to center boom with hinge pin (A) and fasten with bowtie clip (B).

6. Remove bolt (D) and retain.
7. Connect spring (C) to bolts on the hinge backplate. Use of a spring puller will assist with assembly.
8. Reinstall bolt (D) and adjust so that the side boom is in line with center boom when extended.

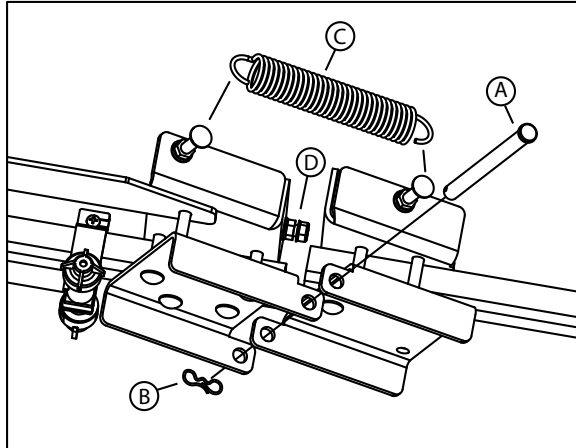

Boom Hose Connections

NOTE: The hoses are the length needed for the 18 ft boom. For the 24 ft and 30 ft booms, cut 8 inches off the hoses for the side booms (A and C). For the boomless sprayers, pull the hoses out to the side fittings and cut as needed, leaving a little slack for adjustment of the control valve assembly.

1. Connect the hoses from the control valve to the appropriate sections of the boom.
2. Fasten with 1/2 inch hose clamps.

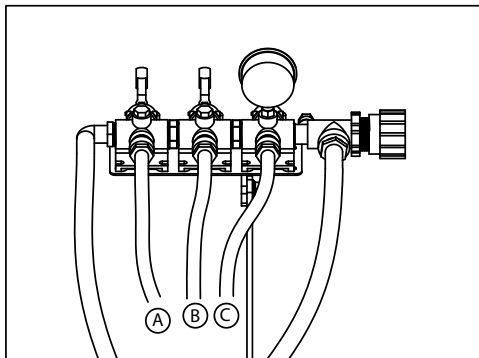

Boom Hoses

1. 18 ft boom: Use the wire ties (A) to fasten the hoses to the top of the square tubing of the side booms approximately 12 inches

away from both sides of the hinge pivot center point. Leave slack in the hose around the hinge area. Be sure the boom folds without pinching the hose.

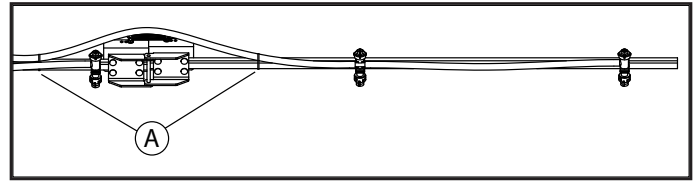

2. 24 ft and 30 ft booms: Use wire ties (A) to fasten the hoses to the flat support piece connecting the side hinges of the side booms, leaving the slack in the hose around the hinge area. Be sure the boom folds without pinching the hose.

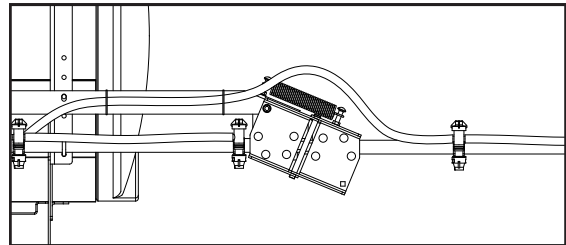

Boom Adjustment

NOTE: 24 ft and 30 ft booms only.

1. Move the cross brace (A) to the appropriate upper position (B) so that when the boom is folded, the rubber bumper (C) stops against the cross brace (A). If the top bolt holding the boom is using the top hole among lower positions (D) the top cross brace will also use the top hole (B).
2. Put the S-Hook (E) through the eyebolt (F) and mark the farthest spot down on the rope where the S-Hook reaches.
3. Fold the boom.
4. Grab the rope with a hand about an inch or two on either side of the marked spot on the rope and push together to open the weave in the rope. Put the opposite end of the S-Hook through the rope.
5. Open boom.
6. Adjust the side boom until it is parallel with the ground either by folding the boom and

attaching the S-Hook out farther on the rope, or adjusting the eyebolt.

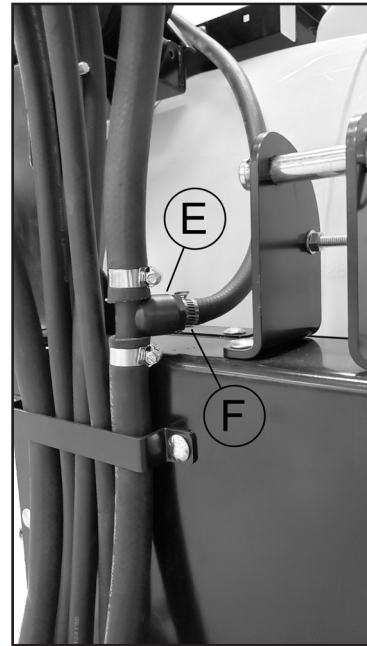
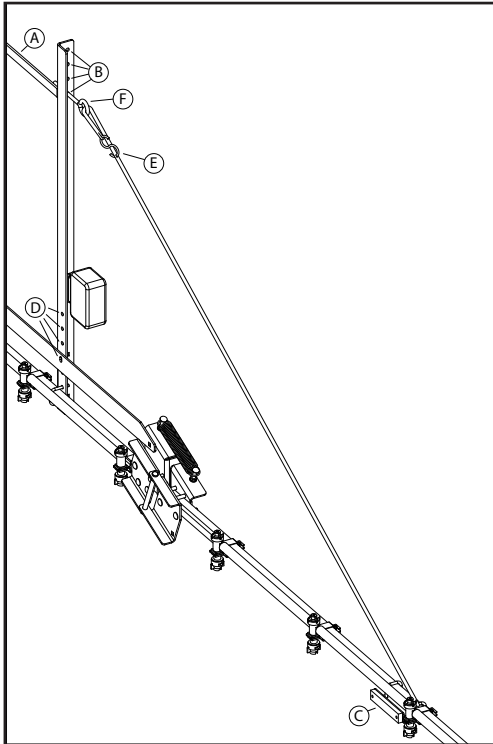

(Optional) Install 100 ft Hose Reel Kit

1. Install Hose Reel (A) on top of Mounting Bracket (B) with the knob facing the front of the sprayer using four 5/16" x 1/4" Carriage Bolts (C) and four 5/16" Flange Nuts (D) as shown.

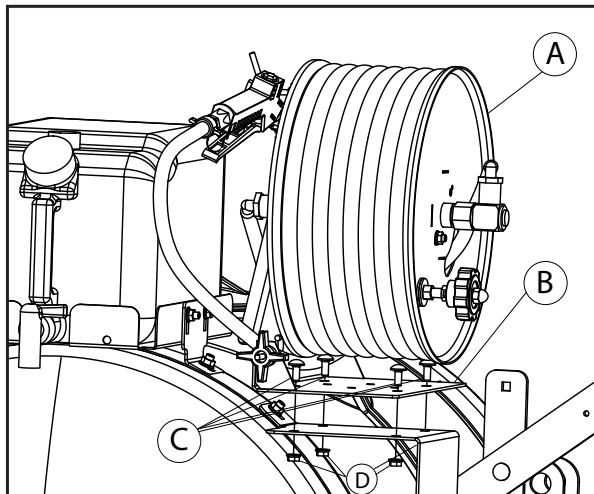

2. Torque all fasteners to recommended torque. (See Torque Table section)
3. Attach free end of 1/2" hose from Hose Reel to Tee Fitting (E) and secure with 1/2" Screw Type Hose Clamp (F).

(Optional) On-Highway Kit Installation

1. Install Right Hand Light Bracket (A) to outside of uprights using two 5/16" x 3/4" Carriage Bolts (B) and two 5/16" Flange Nuts (C). Torque Flange Nuts to recommended torque. (See Torque Table section)
2. Repeat Step 1 for Left Hand Light Bracket.
3. Install Rear Light Assembly (D) on Left Hand and Right Hand Light Brackets ensuring that both the red and amber lights are facing the rear of the sprayer with the amber lights on top, using four 1/4" x 1-1/4" Hex Bolts (E) and four 1/4" Nylock Nuts (F) per light. Nylock nuts should NOT be overtightened as this could crack the plastic light housings.

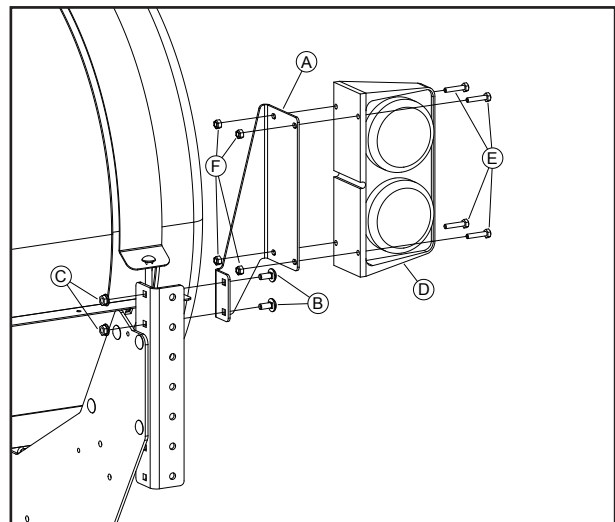

- Loosen Hose Guide Bracket (G) and route Light Kit harness starting with two 4 pin connectors alongside hoses.

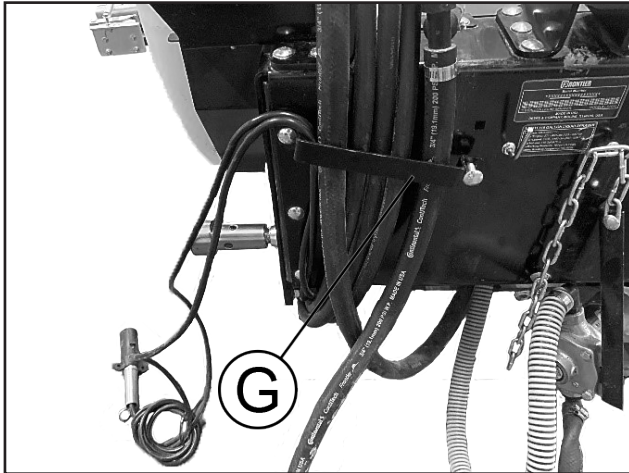

- Continue to route harness under the right side of the sprayer on the inside of the frame and above the brace that holds the drain filter/valve assembly (H).

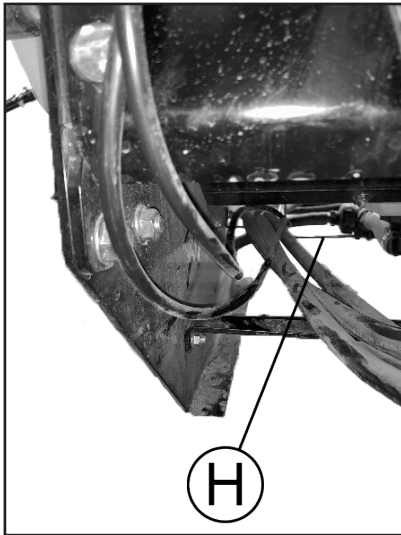

- Route harness section labeled "LEFT" along rear top frame section of sprayer.

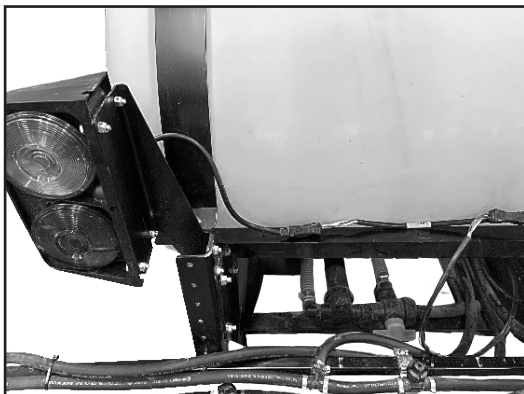

- Connect harness end connectors to right and left lights.
- Install push in cable clamp with wire ties. Five on the inside of the frame section and Three on the top of the back horizontal frame section.
- Remove slack in harness by pulling harness to the front of the sprayer. Tighten wire ties and re-tighten hose guide bracket. Torque hose guide bracket flange nuts to recommended torque. (See Torque Table section)
- Install SMV bracket (J) on the fixed center boom section, slightly left of center, by slipping the bracket between the Hose (K) and Square Tube (L) and secure using 5/16" x 1-3/4" Square U-Bolt (M) and two 5/16" Flange Nuts (N). Torque Flange Nuts to recommended torque. (See Torque Table section)

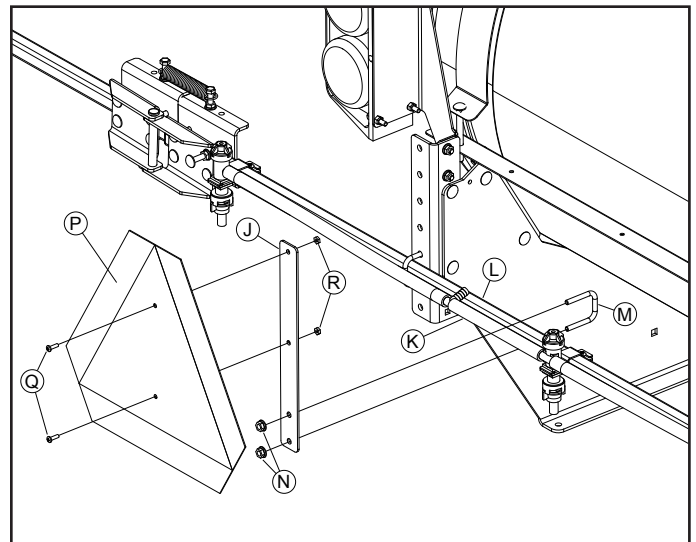

- Connect 7 pin connector to the tractor's trailer plug and test operation of Tail, Stop, and Turn Signal Lights.
- Disconnect 7 pin connector from tractor and hang connector on Spare Hook (S) located on front of sprayer.

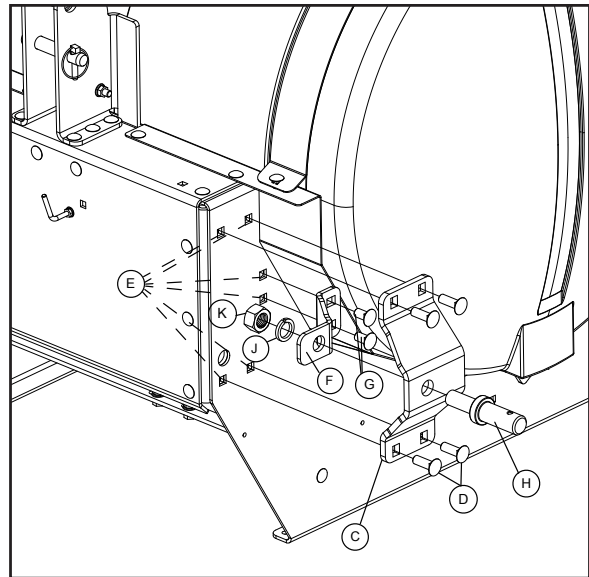
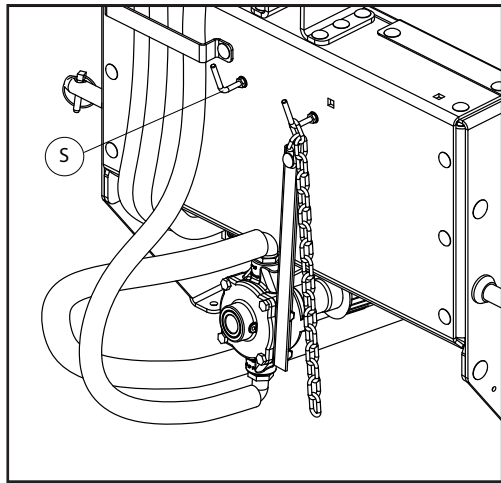

(Optional) Install CAT 2 Pins

1. Starting on left side, remove CAT 1 Pin (A) by removing 7/8" Nut and Lock Washer on backside of frame. Retain hardware and Linch Pin for installing CAT 2 Pin.
2. Remove four 1/2" x 1" Carriage Bolts (B).

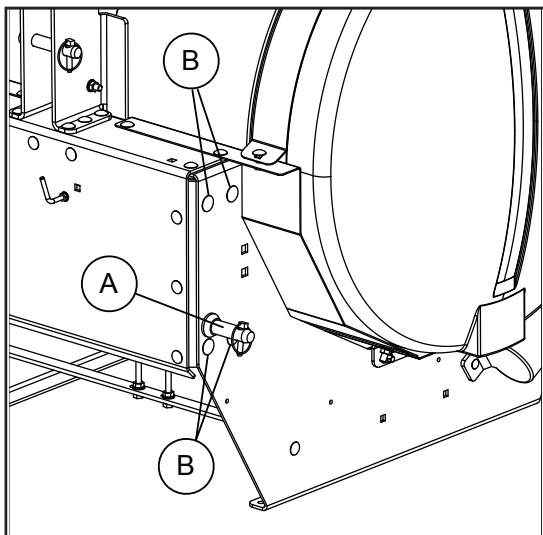

6. Torque hardware in the following order. (See Torque Table section)
 - a. CAT 2 Side Pin Nut (K)
 - b. CAT 2 Side Bracket Flange Nuts (E).
 - c. CAT 2 Brace Flange Nuts (E).
7. Repeat Steps 1-6 for right side.
8. Replace CAT 1 Top Link Pin (L) with CAT 2 Top Link Pin (M) placing the CAT 2 Top Link Pin in the upper holes (N) of the Top Link Bracket and secure with Linch Pin from CAT 1 Top Link Pin.

3. Loosely Install the CAT 2 Side Bracket (C) with the hole for the CAT 2 Pin closer to the front of the sprayer using four 1/2" x 1-1/2" Carriage Bolts (D) and 1/2" Flange Nuts (E).
4. Loosely Install CAT 2 Brace (F) under the CAT 2 Side Bracket using two 1/2" x 1" Carriage Bolts (G) and 1/2" Flange Nuts (E).
5. Install CAT 2 Side Pin (H) by inserting pin into the holes in both the CAT 2 Side Bracket and CAT 2 Brace using the Lock Washer (J) and 7/8" Nut (K) from step 1. Install Linch Pin from Step 1.

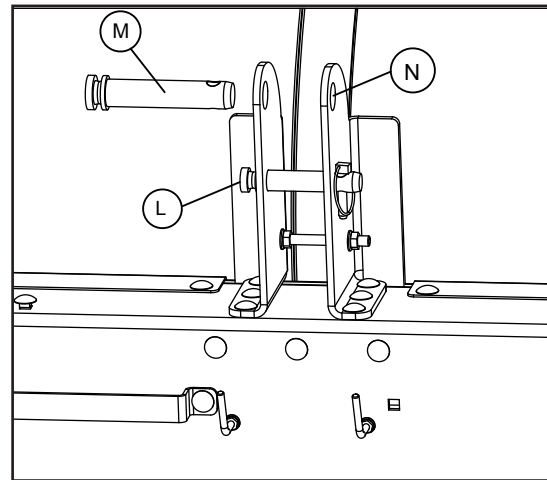

INSTALLATION

Sprayer Installation

Installing Ballast



CAUTION: Avoid Injury! Machine can become unstable when operating with an attachment. Ballast is required when the attachment is installed

- Do not use PTO adapters

Compact Utility Tractors

See Specification Section for implement code and refer to Ballasting Machine in your tractor operator's manual to determine the number of front weights required to ballast the tractor.

Mounting the Pump

1. Connect pump to tractor PTO shaft.
2. Brace torque arm against solid member of tractor frame in the direction of PTO rotation.
DO NOT brace against the 3-point lift arms or any other moving parts.
3. Connect chain fairly tight to tractor frame in opposite direction.

Note: We recommend using the drawbar (if possible) and wrapping the chain as shown below.



Attaching the Sprayer to Tractor

1. Park machine safely. (See Park Machine Safely in Safety section)
2. Lower tractor lift link to lowest position.
3. Mount sprayer on 3-point hitch.

Attaching the Sprayer to Tractor with iMatch - Quick Hitch

1. Connect iMatch – Quick Hitch to tractor first following the iMatch – Quick Hitch installation instructions.
2. Install bushing set (sold separately), John Deere Part Number BW15056 or equivalent, to lower draft pins and top link pin on sprayer.
3. Lower the tractor's 3-pt hitch aligning the center hook of the iMatch – Quick Hitch just below the top link pin on the sprayer.
4. Ensure all three connection points are aligned.
5. Raise tractor's 3-pt hitch ensuring lower draft pins and top link are fully engaged with iMatch – Quick Hitch.
6. Close both levers on iMatch – Quick Hitch to lock lower draft pins in place. Levers are closed when they are folded down (horizontal position).

Removing and Storing Sprayer

Removing Sprayer from Tractor



CAUTION: Avoid Injury! When the attachment is removed, also remove any ballast that was added to the machine.

1. Park machine safely. (See Park Machine Safely in Safety section)
2. Lower sprayer to the ground.
3. Empty the sprayer tank. (See Operation section)
4. Disconnect sprayer from 3-point hitch.
5. Disconnect pump from PTO shaft.
6. Store pump by hanging on hook by the chain so that the pump and hoses do not contact the ground.

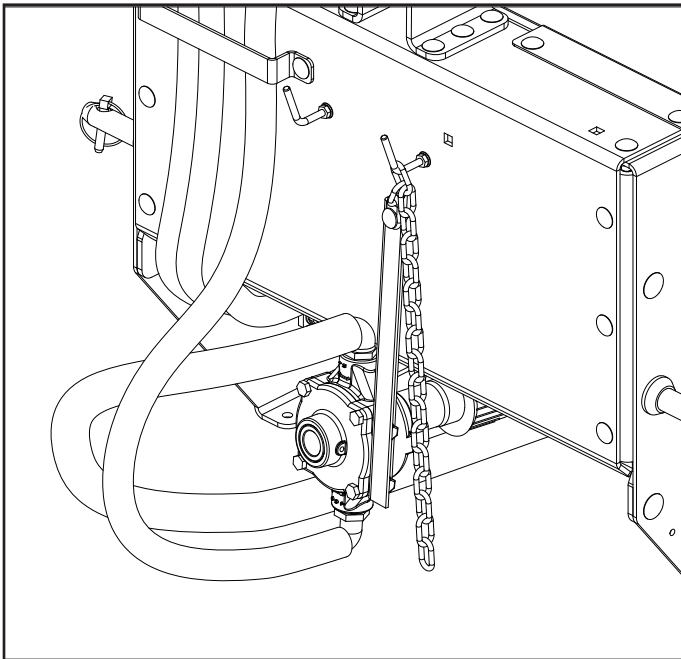

Store Sprayer Safely



CAUTION: Avoid Chemical Injury

- Wear protective clothes, gloves and goggles when handling sprayer.
- Do not store sprayer with chemicals in tank.
 - If sprayer comes in contact with your body, immediately follow directions on chemical container pertaining to spray material.
1. Open 3-way valve and drain excess fluid into chemical disposal container. (See Dispose of Waste Properly in Safety section)
 2. Rinse tank, pump, spray wand and all hoses thoroughly with fresh clean water.
 3. Repeat step 2 several times.
 4. Allow tank to air dry.
 5. Drain hoses and pump filter.
 6. Check sprayer for worn or damaged parts. Replace parts as needed.
 7. Tighten loose hardware.
 8. Store sprayer in a place where it will not freeze.
 9. Store pump by hanging on hook by the chain so that the pump and hoses do not contact the ground.

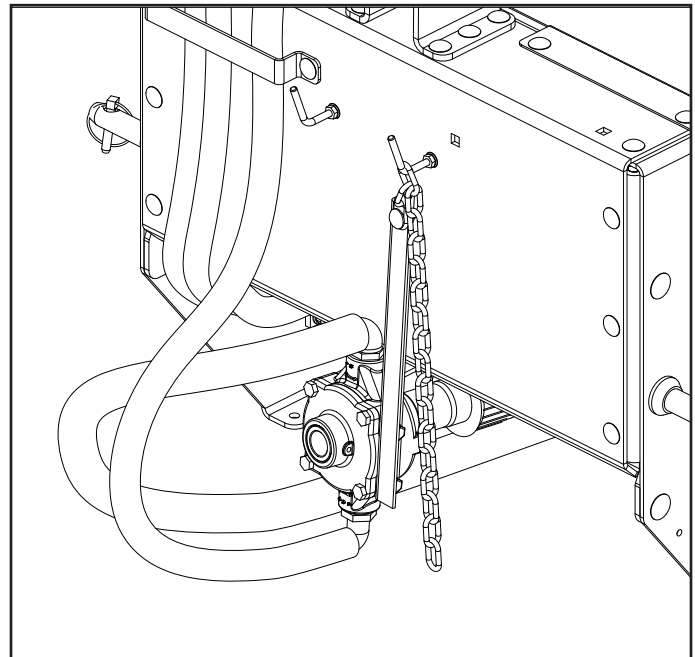

OPERATION

Sprayer Setup

Filling Sprayer Tank



CAUTION: Chemicals can be dangerous. Avoid injury to operator or bystanders.

- Read chemical container label for mixing and handling instructions. A Safety Data Sheet (SDS) should be supplied by the chemical dealer and provides proper safety information.
- Wear proper clothing and safety equipment while handling or applying spray chemicals.
- Wear a full covering of clothing, protective goggles and rubber gloves.
- Prohibit all smoking, drinking, and eating around chemicals.
- When filling tank, never allow end of water hose to contact chemical mixture.

IMPORTANT: Avoid damage! Clean any spills immediately with clean water prior to operating sprayer.

1. Park machine safely. (See Park Machine Safely in Safety section)
2. Lower tractor lift link so that the sprayer is firmly on the ground.
3. Clean area around tank filler cap to prevent tank contamination.
4. Remove tank filler cap and fill tank.
5. Install tank filler cap.

NOTE: The preferred location to fill the tank is from the front left corner.

Draining and Cleaning the Sprayer Tank



IMPORTANT: Avoid damage!

- Clean any spills. Proper disposal of excess spray is very important. Dilute it with water and apply it to area previously treated.
 - Never dump excess into a storm drain or near a lake or stream.
1. To quickly empty the tank of excess material, turn 3-way valve (A) to drain position as shown.

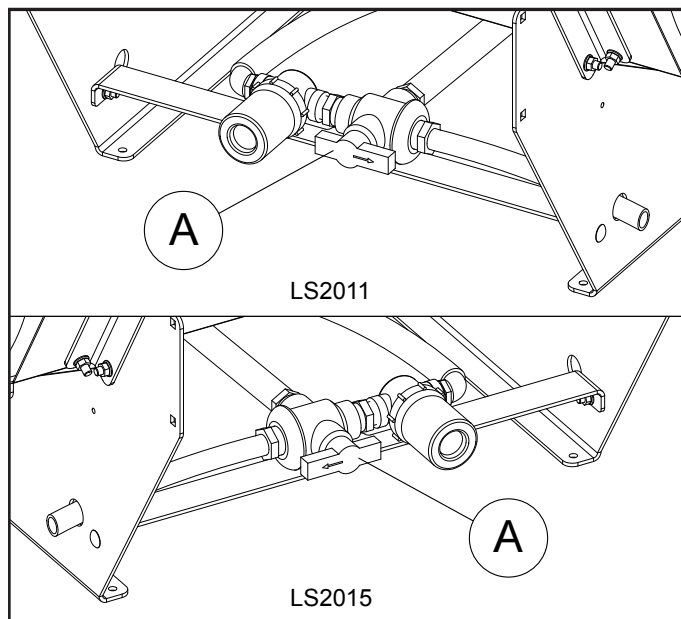

2. Spray all inside surfaces of tank with low pressure garden hose to remove any remaining solution. Rinse sprayer tank, pump, sprayer wand and all hoses thoroughly with fresh, clean water. Rinse several times to make sure sprayer tank is clean and free of chemicals.
3. When tank is empty, Allow tank to air dry.
4. Turn 3-way valve (A) to OFF position (Vertical) and install filler cap.

Calibrating the Sprayer

When spraying with boom, sprayer must be calibrated to ensure proper spray coverage and to combat over-application or under-application. The calibration process consists of three steps:

- Calculate speed of tractor.
- Determine nozzle size and consult calibration chart for desired or instructed gallon per acre (GPA).
- Set pressure using relief valve.

Calculating the Speed

It is important to determine what speed the tractor will be traveling while spraying. Even if tractor has a speedometer, it is still recommended that speed be checked for accuracy. Perform the following steps to determine speed:

1. Measure a 200 or 300 foot distance on a field or surface similar to where sprayer will be used.
2. Drive tractor with half-full sprayer across measured distance at a constant and
3. comfortable speed for spraying. There can be no changes in speed while measuring time.
4. When using a gear-driven tractor, select a gear where PTO is at or near 540 rpm. This is important for pump to provide adequate pressure to sprayer when spraying.
5. Determine amount of time, in seconds, it takes to travel the measured distance.
6. Speed can be determined by entering data into the following equation:
7. $\text{speed (mph)} = (\text{distance (ft)} \times 60) / (\text{time (sec)} \times 88)$ or by consulting the following table:

Speed in MPH	Time (sec) required to travel a distance of:	
	200 ft	300 ft
1.0	136	205
1.5	91	136
2.0	68	102
2.5	55	82
3.0	45	68
3.5	39	56
4.0	34	51
4.5	30	45
5.0	27	41
5.5	25	37
6.0	23	34
6.5	21	31
7.0	19	29

NOTE: If using boomless nozzles, use the Boomless Nozzle Calibration Chart.

Useful Formulas

GPA = Gallons per Acre

GPM = Gallons per Minute

MPH = Miles per Hour

GAL/1000 sq ft = Gallons per 1000 sq ft

W = Nozzle spacing in inches

$\text{GPM Per Nozzle} = \text{GPA} \times \text{MPH} \times \text{W} / 5940$

$\text{GPM Per Nozzle} = \text{GAL}/1000 \text{ sq ft} \times \text{MPH} \times \text{W} / 136$

$\text{GPA} = 5940 \times \text{GPM (Per Nozzle)} / \text{MPH} \times \text{W}$

$\text{GPA} = \text{Gallons per 1000 sq ft} / 0.023$

$\text{GAL}/1000 \text{ sq ft} = 136 \times \text{GPM (Per Nozzle)} / \text{MPH} \times \text{W}$

Determining Nozzle Size and Using Calibration Chart

24 FT AND 30 FT BOOM CALIBRATION CHART						
Tip Size	PSI	GPM one nozzle	GPA (20" spacing)			
			4 MPH	5 MPH	6 MPH	8 MPH
AIC11004	30	0.35	26.0	21.0	17.3	13.0
	40	0.40	30.0	24.0	19.8	14.9
	50	0.45	33.0	27.0	22.0	16.7
	60	0.49	36.0	29.0	24.0	18.2

18 FT BOOM CALIBRATION CHART						
Tip Size	PSI	GPM one nozzle	GPA (30" spacing)			
			4 MPH	5 MPH	6 MPH	8 MPH
AIC11004	30	0.35	17.3	14.0	11.5	8.7
	40	0.40	20.0	16.0	13.2	9.9
	50	0.45	22.0	18.0	14.7	11.1
	60	0.49	24.0	19.3	16.0	12.1

The spray nozzles on your sprayer are AIC11004, which match up with the calibration chart. Refer to the calibration chart. Using tractor speed, nozzle size, and desired gallons per acre (GPA), calculate pressure (psi) necessary to achieve your GPA. It is important to note that lower pressure settings will result in less spray drift.

Example:

Assume tractor speed is determined to be 4 mph, nozzles are red (AIC11004) 30", and desired GPA is 20 GPA. The calibration charts shows that you should set sprayer's pressure at about 40 psi in order to apply 20 GPA.

Boomless Calibration

Right and Left Nozzles: 1/4XP20

Center Nozzle: 1/4TTJ08

BOOMLESS CALIBRATION CHART FOR 24" HEIGHT						
PSI	Cap. 3 Nozzle GPM	Spray Width "ft"	GPA			
			4 MPH	6 MPH	8 MPH	10 MPH
30	4.2	26.3	19.7	13.1	9.9	7.9
40	4.8	30.3	19.6	13.1	9.8	7.8
50	5.4	32.3	21.0	13.8	10.3	8.3
60	6.0	33.3	22.0	14.8	11.1	8.9

BOOMLESS CALIBRATION CHART FOR 36" HEIGHT						
PSI	Cap. 3 Nozzle GPM	Spray Width "ft"	GPA			
			4 MPH	6 MPH	8 MPH	10 MPH
30	4.2	27.3	19.0	12.7	9.5	7.6
40	4.8	31.3	19.0	12.7	9.5	7.6
50	5.4	33.3	20.0	13.4	10.0	8.0
60	6.0	35.3	21.0	14.0	10.5	8.4

Adjusting the Sprayer Pressure

NOTE: All calibration needs to be done with clean water.

Once correct pressure setting has been determined, the sprayer must be adjusted to that pressure setting. Before adjusting sprayer's pressure, it is important to set tractor rpm at rate that was used to determine tractor speed.

1. Loosen lock ring (A) and adjust knob (B) to desired pressure. Pressure is displayed on gauge (C).
2. Once desired pressure is achieved tighten lock ring (A).
3. Sprayer is now calibrated.

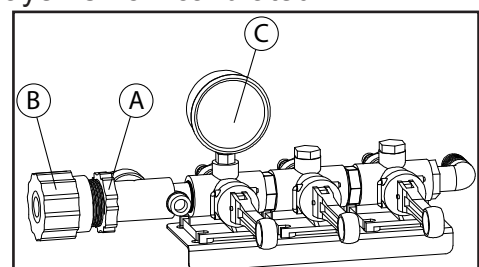

Operating the Sprayer

Pump Safety Precautions



CAUTION: Chemicals can be dangerous. Avoid injury to operator or bystanders.

- Read chemical container label for mixing and handling instructions. A Safety Data Sheet (SDS) should be supplied by the chemical dealer and provides proper safety information. Wear proper clothing and safety equipment while handling or applying spray chemicals.
- Wear a full covering of clothing,
- protective goggles and rubber gloves.
- Prohibit all smoking, drinking, and eating around chemicals.
- When filling tank, never allow end of water hose to contact chemical mixture.

IMPORTANT: Avoid damage! Clean any spills immediately with clean water prior to operating sprayer.

- Do not pump flammable or explosive fluids such as gasoline, fuel oil, or kerosene.
- Do not pump acids (i.e., acid fertilizer) with super rollers. For acid fertilizer, Hypro recommends Silver Series cast with Teflon rollers (5CS43649 or 5CS43788).
- Do not run pump dry! Do not pump faster or above maximum recommended speed and pressure (1200 rpm, 300 psi).
- Do not pump liquids at temperatures higher than recommended maximum temperature (60°C, 140°F).
- Disengage PTO, release all pressure and drain all liquids before servicing pump.

Spraying with the Boom

1. Calibrate the sprayer to achieve the desired gallons per acre (GPA). Refer to Calibrating the Sprayer and the Calibration Chart to determine the correct pressure settings.

2. Connect pump PTO coupler to PTO shaft.
3. Fill tank with water to set pressure and test for leaks.
4. Prepare to spray by turning section control valves to OFF and the 3-way valve (A) to the ON position as shown.

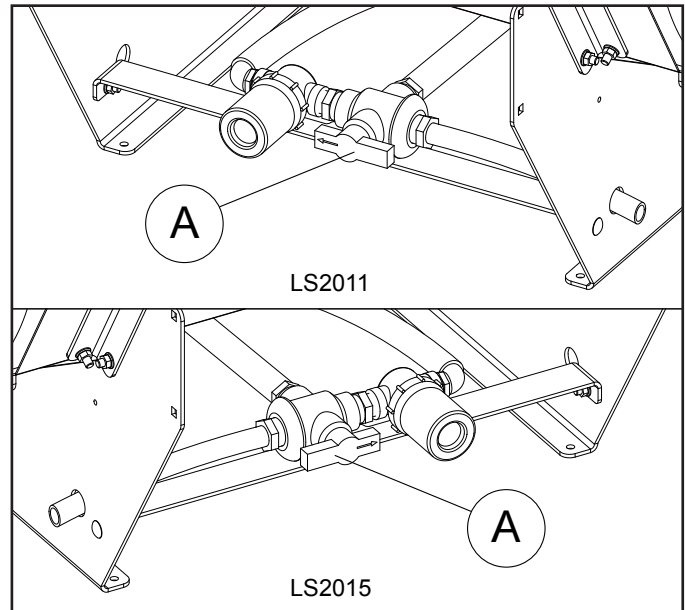

5. Start tractor and engage PTO. For adequate spraying pressure and tank agitation, PTO should be running at or near 540 rpm. Ensure pump is primed and there are no leaks in any lines.
6. Use relief valve to adjust sprayer pressure to pressure rating determined during sprayer calibration. When opening control valve, it may be necessary to adjust pressure again.
7. Ensure that tractor PTO is disengaged. Fill tank with amount of water and chemicals recommended by chemical being used. After filling tank, engage pump and allow ample amount of time for jet agitator to mix water and chemicals.

NOTE: Do not start sprayer operation until chemicals and water are mixed for the recommended time listed on the chemical instructions.

8. At spraying location, unfold the boom at locations away from hinges.

9. Engage PTO, and make sure pressure setting is correct. While spraying, maintain a constant level of speed and rpm (rates determined when calibrated).
10. When complete, fold boom back into transport position. On 24 ft and 30 ft boom ensure the retaining strap is in place.

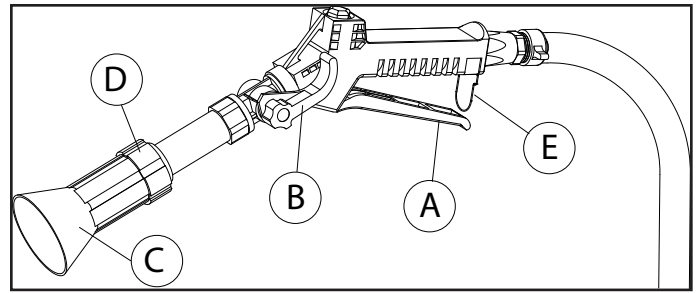

Boom Section Control

The Boom is divided into 3 sections of spray tips. Right, Center and Left. Each section can be turned ON and OFF individually using the boom section control valves.

1. To turn a section ON move the corresponding handle to the horizontal position.
2. To turn a section OFF move the handle to the down position.
 - Right Section (A), Center Section(B), Left Section (C)

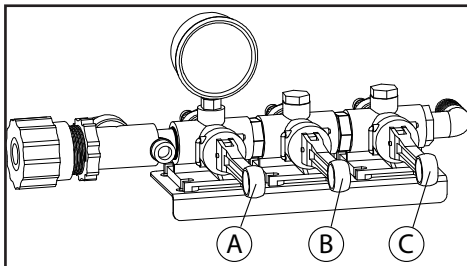

Spraying with the Spray Nozzle



CAUTION: Avoid Injury! DO NOT use spray nozzle while tractor is in motion.

1. Turn all Section Control valves to OFF.
2. Squeeze the handle (A) to spray.
3. Adjust mist to stream using lever (B).
4. Spray guard (C) can be adjusted by loosening (D) and sliding spray guard to desired position. The spray guard is intended to keep over-spray off your hands.
5. Flip handle lock (E) forward to lock handle in ON position.

SERVICE

Servicing Sprayer

Servicing Sprayer Safely



CAUTION: Chemicals can be dangerous. Avoid injury to operator or bystanders.

- Wear protective clothes, gloves and goggles when handling sprayer.
- Do not put the nozzle tips or other parts to your lips to blow out dirt.
- If spray comes in contact with your body, immediately follow directions on chemical container pertaining to spray material.

Servicing the Pump

Follow all pump safety precautions and warnings. Following these guidelines will help to ensure many years of smooth and trouble-free sprayer operation.

- Flush pump out with fresh water after every use.
- Winterize pump to prevent freezing and corrosion.
- Refer to Winterizing Sprayer for instructions.
- Change seals and rollers if pump is leaking or has a noticeable decrease in performance.

Winterizing Sprayer

It is important to winterize sprayer to avoid damage from freezing and corrosion before temperatures reach freezing levels.



CAUTION: Avoid injury! Do not use standard antifreeze. Standard antifreeze can be harmful to humans, animals, crops and the environment.

1. Empty and rinse tank.
2. Put one to two gallons of RV nontoxic antifreeze in tank.
3. Engage pump and spray with boom and

subsequently spray gun (if applicable). Ensure that antifreeze has been pumped through entire system, including all spray nozzles.

4. Store sprayer in a dry location away from elements.

Placing Sprayer Back in Service after Winterizing

1. Flush sprayer with fresh water to clean out all antifreeze and any other buildup.
2. Do a thorough inspection of all components before spraying.

Cleaning Spray Tips



CAUTION: Avoid injury!

- Wear protective clothes, gloves and goggles when handling sprayer.
 - Do not put the nozzle tips or other parts to your lips to blow out dirt.
 - If spray comes in contact with your body, immediately follow directions on chemical container pertaining to spray material.
1. Remove spray nozzle (A) from sprayer.
 2. Remove the spray tip (B) and gasket (C) from the spray nozzle (A).
 3. Remove the screen (D) from the nozzle socket on the boom. Replace the screen if damaged.

IMPORTANT: Avoid damage! Do not use a wire to clean the opening (E) in the spray tip.

4. Wash the screen (D) and spray tip (B) in a nonflammable solvent.
5. Align the flat side (F) of the spray tip with the flat on the opening of the spray nozzle (A), and install the spray tip into the nozzle.

NOTE: Verify that the opening (E) in the spray tip is pointing down when the nozzle assembly is installed on the nozzle socket.

6. Install the screen (D) into the nozzle socket on the boom.
7. Install nozzle assembly on the nozzle socket.

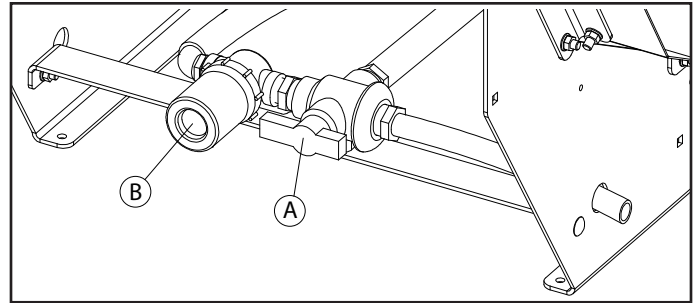
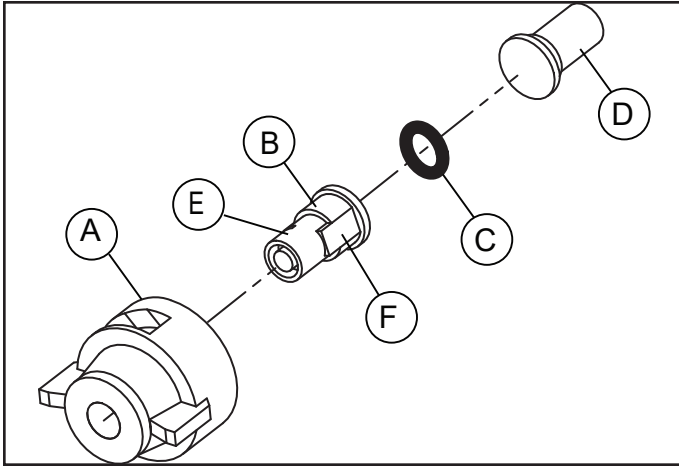

3. Unscrew filter Housing (B) and remove filter.
4. To clean filter flush with clean water and reinstall filter. Ensure filter housing is tight.
5. Turn 3-way valve (A) to ON Position (towards filter) and check for leaks around filter housing.

Quality Service

Frontier Quality Continues with Quality Service

Frontier provides a process to handle your questions or problems, should they arise, to ensure that product quality continues with your Frontier dealer's parts and service support.

Follow the steps below to get answers to any questions you may have about your product.

1. Refer to the appropriate attachment, machine or equipment operator's manuals.
2. Contact your Frontier dealer with unanswered questions.

NOTE: Due to normal wear, Teejet® recommends replacing sprayer nozzles after every spraying season. Nozzle replacement will ensure accurate spraying performance.

Cleaning and Replacing Filter



CAUTION: Chemicals can be dangerous. Avoid injury to operator or bystanders.

- Wear protective clothes, gloves and goggles when handling sprayer.
- Do not put the nozzle tips or other parts to your lips to blow out dirt.
- If spray comes in contact with your body, immediately follow directions on chemical container pertaining to spray material.

NOTICE: Spray material captured in hoses may leak out when filter is removed. Clean the area immediately after servicing.

1. Turn all Section Control valves to OFF.
2. Turn 3-way valve (A) to OFF Position (vertical).

TROUBLESHOOTING

Troubleshooting Sprayer

Using the Troubleshooting Chart

If you are experiencing a problem that is not listed in this chart, see your authorized dealer for service.

When you have checked all the possible causes listed and you are still experiencing the problem, see your authorized dealer.

Troubleshooting Chart

IF	CHECK
Pump Loses Suction	Clean pump suction screen. Check tank fill level. Fill tank. Clean or replace pump. Check for loose pump fittings.
Pump Capacity Decreased	Clean pump suction screen. Clean spray nozzle(s). Selection lever is not completely turned on, or is in the OFF position.
Poor Spray Pattern	Clean spray nozzles. Adjust nozzle height. Align spray tips with boom.
Pump Does Not work	Clean debris from pump.

SPECIFICATIONS

LS2011 Specifications

		Boom Option			
		18 ft	24 ft	30 ft	Boomless
Capacity	Sprayer Tank	110 gal (416 L)			
	Fresh Water Tank	5 gal (19 L)			
Dimension	Working Width	18 ft (5.5 m)	24 ft (7.3 m)	30 ft (9.1 m)	30 ft (9.1 m)
	Transport Width	77 in (196 cm)	76 in (193 cm)	76 in (193 cm)	42 in (107 cm)
	Transport Length	57 in (145 cm)	54 in (137 cm)	54 in (137 cm)	51 in (130 cm)
	Transport Height	57 in (145 cm)	83 in (211 cm)	89 in (226 cm)	57 in (145 cm)
Weight	Empty Weight	271 - 450 Lbs (123 - 204 Kg)			
	Laden Weight	1229 - 1450 Lbs (557 - 658 Kg)			
Tractor Requirement	Hitch Compatibility	CAT 1 (CAT 2 Optional Kit 5CS0023)			
	Quick Hitch Compatability	Yes			
	On Highway Kit				
	Connection	7 pin Trailer Plug (SAE J560)			
Pump	Pump A	Hypro 6 roller PTO Cast Iron (6500C)			Hypro 6 roller PTO Cast Iron (6500C)
	Max Flow @ 540 RPM	9.7 gpm (36.7 l/min)		-	9.7 gpm (36.7 l/min)
	Max Pressure	300 psi (20.7 bar)		-	300 psi (20.7 bar)
	Pump B	Hypro 6 roller PTO Silver Cast (6500XL)			Hypro 6 roller PTO Silver Cast (6500XL)
	Max Flow @ 540 RPM	9.7 gpm (36.7 l/min)		-	9.7 gpm (36.7 l/min)
	Max Pressure	300 psi (20.7 bar)		-	300 psi (20.7 bar)
	Pump C			Hypro 7 roller PTO Cast Iron (7700C)	
	Max Flow @ 540 RPM	-	-	14.2 gpm (53.8 l/min)	-
	Max Pressure	-	-	200 psi (13.8 bar)	-
	Pump D			Hypro 7 roller PTO Silver Cast (7700XL)	
	Max Flow @ 540 RPM	-	-	14.2 gpm (53.8 l/min)	-
	Max Pressure	-	-	200 psi (13.8 bar)	-
Boom	Type	Dry boom			N/A
	Hose Size	1/2 in (1.3 cm)	1/2 in (1.3 cm)	1/2 in (1.3 cm)	1/2 in (1.3 cm)
	Construction	Square tube			N/A
	Breakaway	Rear			N/A
	Fold	Manual			N/A
	Sections	3	3	3	3

LS2011 Specifications

Application System	Spray Tips				
	Qty	7	14	18	3
	Type	Air Induction, 110° Flat Spray			Flood
	Size (gpm)	0.4 gpm (1.5 l/min)	0.4 gpm (1.5 l/min)	0.4 gpm (1.5 l/min)	0.5 gpm (1.9 l/min)
	Spacing	30 in (76 cm)	20 in (51 cm)	20 in (51 cm)	N/A
	Nozzle Body	1/4 turn diaphragm with check valve			
	Control System				
	Pump Control	PTO			
	Pressure Control	Adjustable			
	Max Working Pressure	150 psi (10.3 bar)			
	Section Control	6B Control Valves			
	Agitation	Jet Agitation			
	Spot Sprayer				
	Style	Spray Gun			
	Hose Length	30 ft (9.1 m)			
	Optional Hose Reel				
	Hose Length	100 ft (30.5 m)			

TRACTOR BALLASTING

LS2011 110 Gallon Sprayer 18 ft Boom, 24 ft Boom, 30 ft Boom, and Boomless

Boom Options				Accessories	Full Tank	
30ft Boomless	30ft Boom	24ft Boom	18ft Boom	100ft Hose Reel	Weight (lbs)	Implement Code
			X		1263	71
			X	X	1319	73
		X			1304	74
		X		X	1360	76
	X				1314	74
	X			X	1370	77
X					1229	68
X				X	1285	70

Note: Road Lighting Kit (5CS0017) included in tractor ballasting information.

LS2015 150 Gallon Sprayer 18 ft Boom, 24 ft Boom, 30 ft Boom, and Boomless

Boom Options				Accessories	Full Tank	
30ft Boomless	30ft Boom	24ft Boom	18ft Boom	100ft Hose Reel	Weight (lbs)	Implement Code
			X		1619	90
			X	X	1675	93
		X			1660	93
		X		X	1716	96
	X				1670	94
	X			X	1726	97
X					1585	88
X				X	1641	90

Note: Road Lighting Kit (5CS0017) included in tractor ballasting information.

PARTS DIAGRAMS

Safety Decals Kit and Model Decals

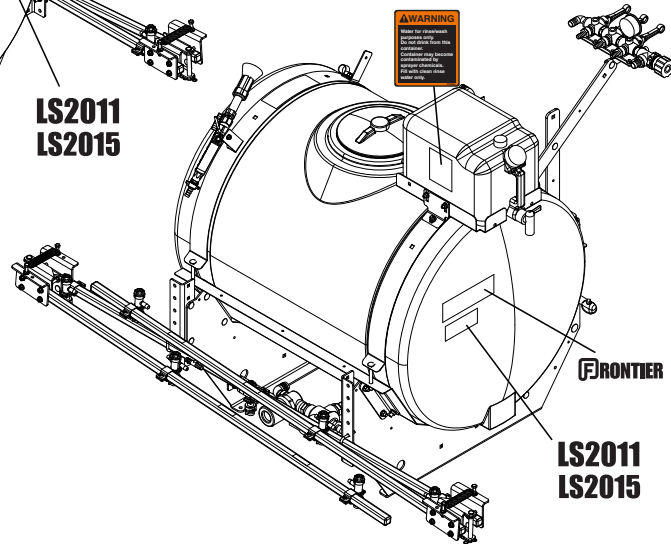
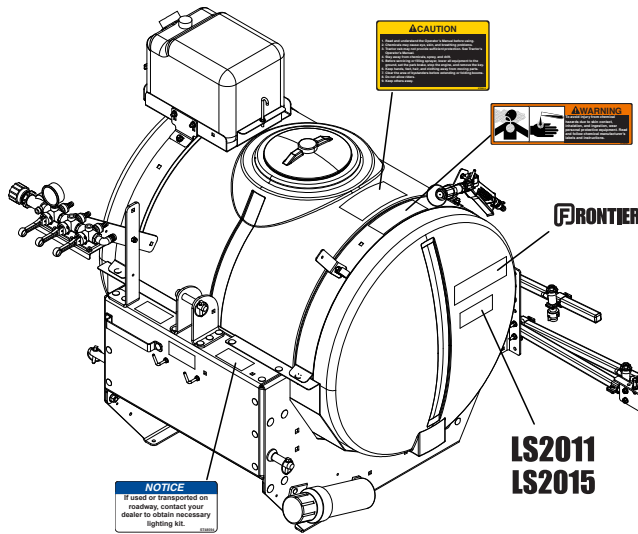

- 1 - English
- 2 - French
- 3 - Spanish

- 4 - English
- 5 - French
- 6 - Spanish

CAUTION

1. Read and understand the Operator's Manual before using.
2. Chemicals may cause eye, skin, and breathing problems.
3. Tractor cab may not provide sufficient protection. See Tractor's Operator's Manual.
4. Stay away from chemicals, spray, and dirt.
5. Before servicing or filling sprayer, lower all equipment to the ground, set the park brake, stop the engine, and remove the key.
6. Keep hands, feet, hair, and clothing away from moving parts.
7. Clear the area of bystanders before extending or folding booms.
8. Do not allow riders.
9. Keep others away.

WARNING

Water for rinse/wash purposes only. Do not drink from this container. Container may become contaminated by sprayer chemicals. Fill with clean rinse water only.

WARNING

To avoid injury from chemical residues due to skin contact, irritation, and absorption, wear personal protective equipment. Read and follow chemical manufacturer's labels and instructions.

OPERATOR'S MANUAL

LIQUID SPRAYER

LS2011
LS2015



FRONTIER

NOTICE

If used or transported on roadway, contact your dealer to obtain necessary lighting kit.

ST48594

Operator's Manual and Safety Decal Kit

CAUTION

1. Read and understand the Operator's Manual before using.
2. Chemicals may cause eye, skin, and breathing problems.
3. Tractor cab may not provide sufficient protection. See Tractor's Operator's Manual.
4. Stay away from chemicals, spray, and dirt.
5. Before servicing or filling sprayer, lower all equipment to the ground, set the park brake, stop the engine, and remove the key.
6. Keep hands, feet, hair, and clothing away from moving parts.
7. Clear the area of bystanders before extending or folding booms.
8. Do not allow riders.
9. Keep others away.

WARNING

Water for rinse/wash purposes only. Do not drink from this container. Container may become contaminated by sprayer chemicals. Fill with clean rinse water only.

WARNING

To avoid injury from chemical residues due to skin contact, irritation, and absorption, wear personal protective equipment. Read and follow chemical manufacturer's labels and instructions.

OPERATOR'S MANUAL

LIQUID SPRAYER

LS2011
LS2015



FRONTIER

NOTICE

If used or transported on roadway, contact your dealer to obtain necessary lighting kit.

ST48594

Replacement Safety Decal Kit

Safety Decals Kit and Model Decals

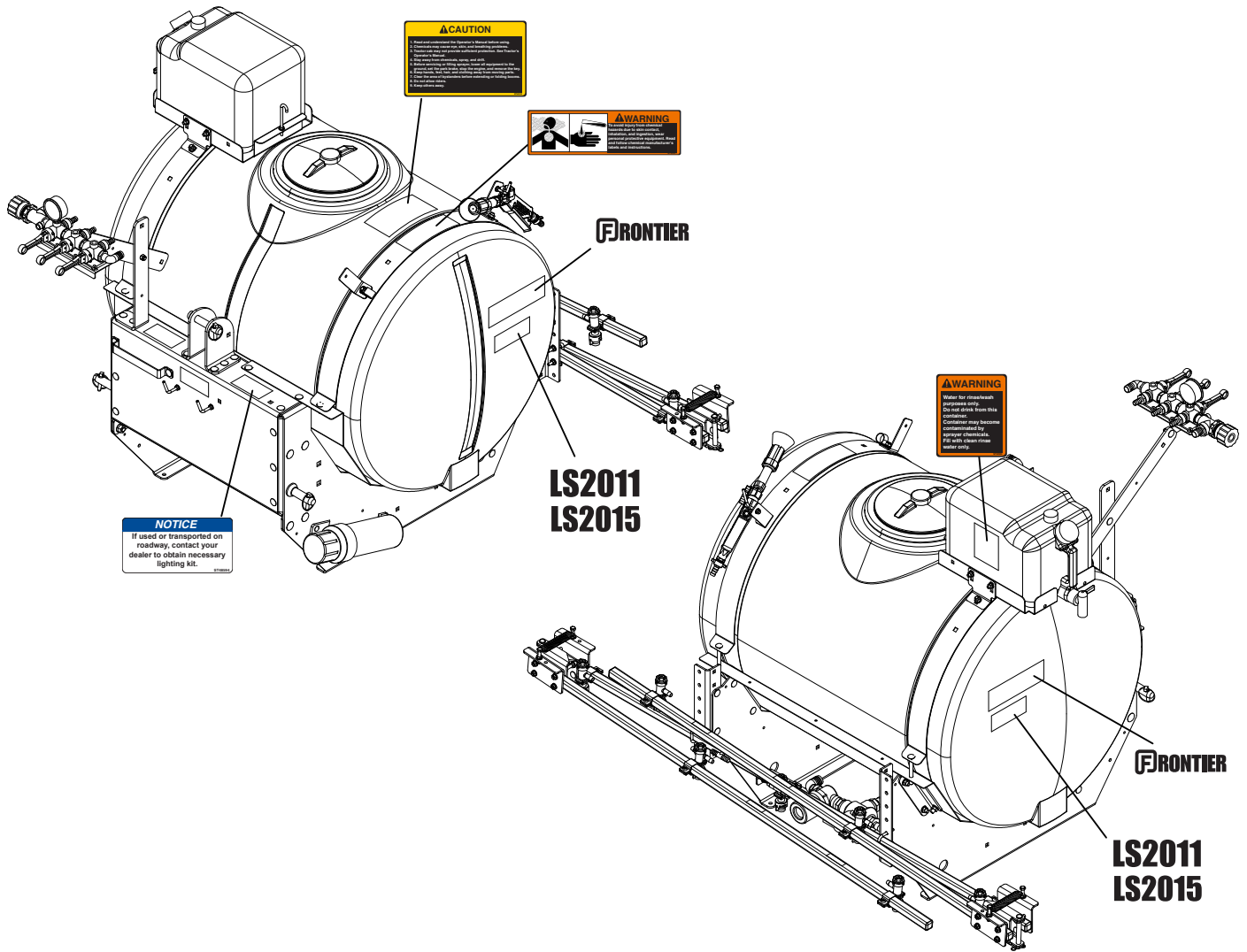

7

FRONTIER
Qty. 2

LS2011
Qty. 2

Replacement Decal Kit - LS2011

8

FRONTIER
Qty. 2

LS2015
Qty. 2

Replacement Decal Kit - LS2015

Safety Decals Kit and Model Decals

ITEM NO.	PART NUMBER	DESCRIPTION	QTY.	Note
1	5CS0026	OM and Safety Decal Kit - English	1	Includes Operator's Manual, Qty 2 Caution Label, Warning Label and Notice label
2	5CS0029	OM and Safety Decal Kit - French	1	
3	5CS0032	OM and Safety Decal Kit - Spanish	1	
4	5CS44001	Replacement Safety Decal Kit - English	1	Includes Qty 2 Caution Label, Warning Label and Notice label
5	5CS44002	Replacement Safety Decal Kit - French	1	
6	5CS44003	Replacement Safety Decal Kit - Spanish	1	
7	5CS44004	Replacement Decal Kit - LS2011	1	Includes Qty 2 Frontier Decal and Qty 2 Model Decal
8	5CS44005	Replacement Decal Kit - LS2015	1	Includes Qty 2 Frontier Decal and Qty 2 Model Decal

110 Gallon Plumbing

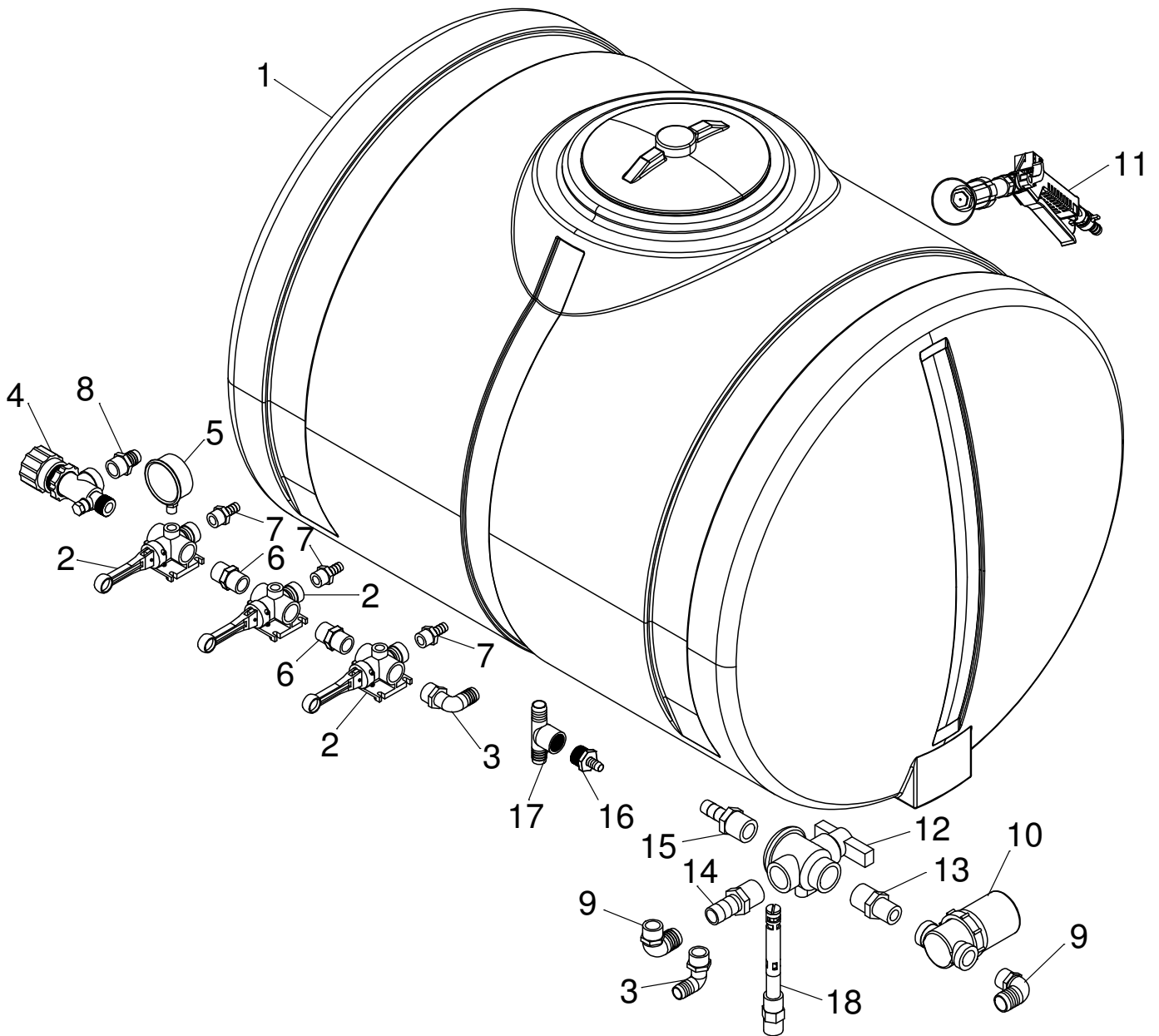

ITEM NO.	PART NUMBER	DESCRIPTION	QTY.	Note
1	5CS43723	110 Gallon Tank	1	
2	5CS43634	Control Valve	3	
3	5CS43633	Elbow 3/4" MP - 3/4" barb	2	
4	5CS43635	Relief Valve 3/4"	1	
5	5CS43987	Gauge 160 PSI	1	
6	5CS43630	3/4" Pipe Nipple	2	
7	5CS43423	Fitting 1/2 Barb - 1/2 MP	3	
8	5CS43636	Fitting 3/4" MP - 3/4" barb	1	

110 Gallon Plumbing

ITEM NO.	PART NUMBER	DESCRIPTION	QTY.	Note
9	5CS43638	Elbow 3/4" MP - 1" barb	2	
10	5CS43631	Filter	1	
11	5CS43435	Sprayer Handgun	1	
12	5CS43974	3 Way Ball Valve 1"	1	
13	5CS43975	Fitting 1" MP - 3/4" MP	1	
14	5CS43976	Fitting 1" MP - 1" Hose Barb	1	
15	5CS43977	Fitting 1" MP - 3/4" Hose Barb	1	
16	5CS43641	Fitting 3/4" MP - 1/2" Hose	1	
17	5CS43640	Tee, 3/4" Hose - 3/4" Hose - 3/4" FP	1	
18	5CS43661	Jet Agitator	1	

110 Gallon Hoses

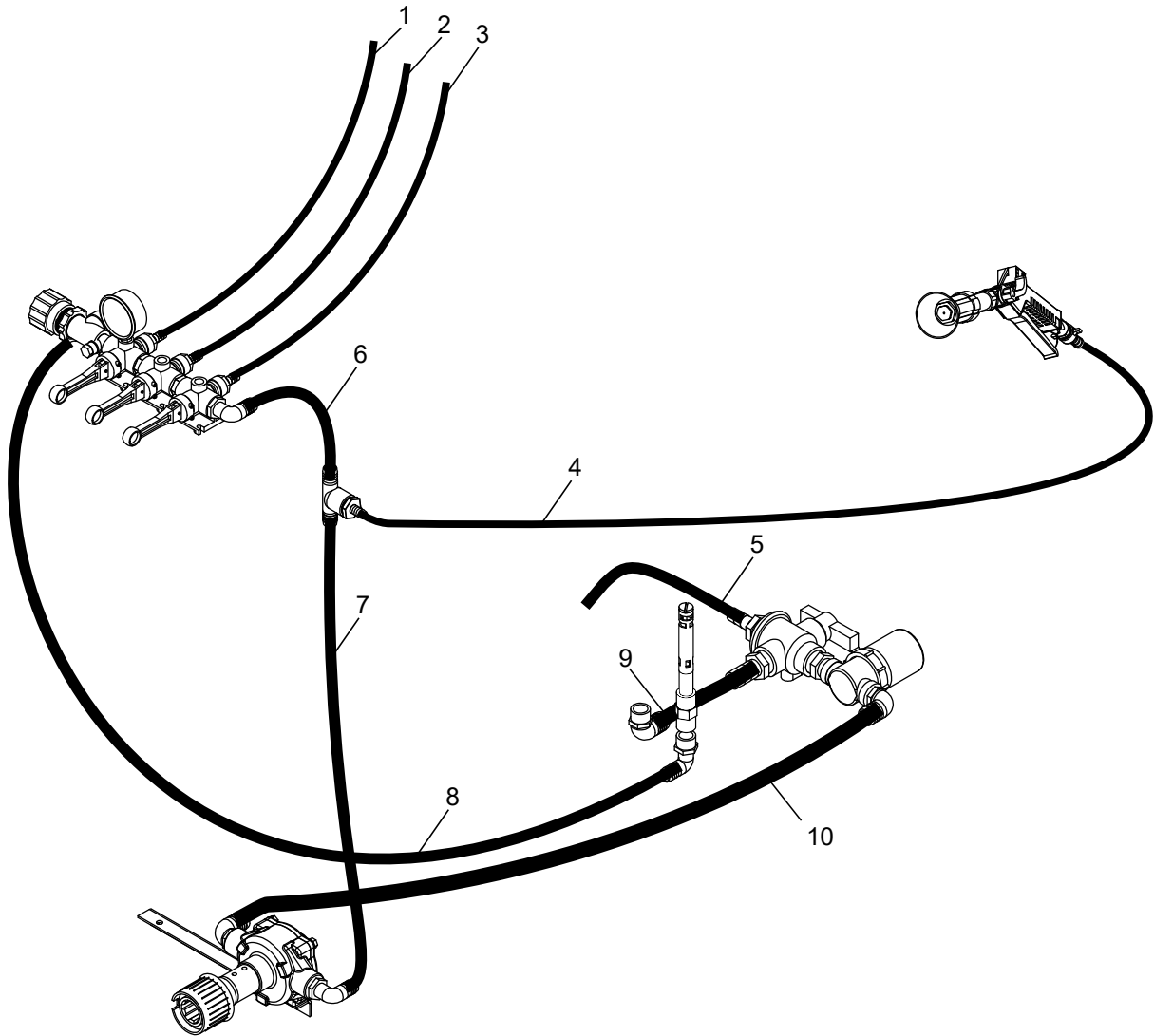

ITEM NO.	PART NUMBER	DESCRIPTION	QTY.	Note
1		1/2" Hose	1	CTL 108", MF 5CS43418
2		1/2" Hose	1	CTL 144", MF 5CS43418
3		1/2" Hose	1	CTL 156", MF 5CS43418
4		1/2" Hose	1	CTL 360", MF 5CS43418
5		Hose 3/4"	1	CTL 12", MF 5CS43656

110 Gallon Hoses

ITEM NO.	PART NUMBER	DESCRIPTION	QTY.	Note
6		Hose 3/4"	1	CTL 24", MF 5CS43656
7		Hose 3/4"	1	CTL 60", MF 5CS43656
8		Hose 3/4"	1	CTL 72", MF 5CS43656
9		Suction Hose 1"	1	CTL 8", MF 5CS43654
10		Suction Hose 1"	1	CTL 56", MF 5CS43654
-	5CS43652	Hose Clamp Screw Type 3/8" - 1/2"	8	Not Illustrated
-	5CS43653	Hose Clamp Screw Type 3/4"	6	Not Illustrated
-	5CS43654	Hose Clamp Screw Type 1"	4	Not Illustrated

110 Gallon Frame

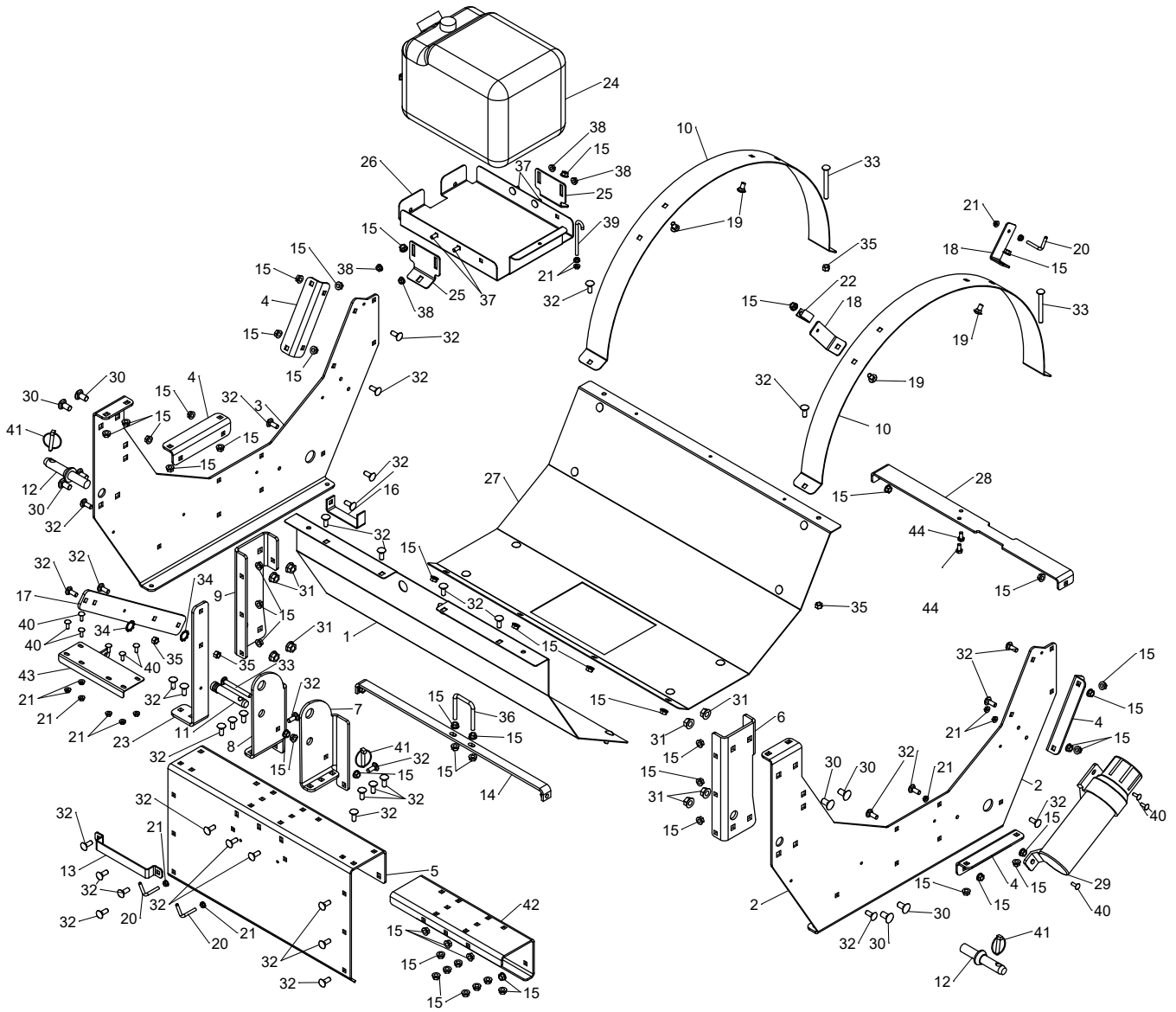

ITEM NO.	PART NUMBER	DESCRIPTION	QTY.	Note
1	5CS43953	110 gal Tank Support Front	1	
2	5CS43957	Frame Left	1	
3	5CS43958	Frame Right	1	
4	5CS43699	Tray Support Angle	4	
5	5CS43959	Frame Front	1	
6	5CS43960	Front Angle LH	1	
7	5CS43989	Top Pin Bracket LH	1	
8	5CS43990	Top Pin Bracket RH	1	
9	5CS43961	Front Angle RH	1	

110 Gallon Frame

ITEM NO.	PART NUMBER	DESCRIPTION	QTY.	Note
10	5CS43715	Tank Strap	2	
11	5CS43399	Top Pin, Cat 1	1	
12	5CS61509	Cat 1 Pin with Hardware	2	
13	5CS43733	Hose Guide Front	1	
14	5CS43734	Bottom Brace	1	
15	E55662	3/8" Flange Nut	64	
16	5CS43746	Hose Guide Rear	1	
17	5CS43745	Control Post Support	1	
18	5CS43747	Spray Gun Bracket	2	
19	5CS65081	3/8" x 3/4" Carriage Bolt	4	
20	5CS62008	1/4" Bent Pin	3	
21	N10217	1/4" Flange Nut	17	
22	5CS43663	Hose Holder 1/2"	1	
23	5CS43964	Control Post Support	1	
24	5CS43978	Fresh Water Tank	1	
25	5CS43966	Fresh Water Tank Bracket	2	
26	5CS43965	Fresh Water Tank Tray	1	
27	5CS43954	110 gal Tank Support Rear	1	
28	5CS43972	Valve Support	1	
29	5CS43950	Manual Canister	1	
30	5CS65044	1/2" x 1" Carriage Bolt	8	
31	5CS65037	1/2" Flange Nut	8	
32	03H1500	3/8" x 1" Carriage Bolt	55	
33	5CS65002	3/8" x 3-1/2" Carriage Bolt	3	
34	5CS65054	3/4" Star Lock Washer	2	
35	T11234	3/8" Nylock Nut	4	
36	5CS60072	3/8" U-Bolt	1	
37	03H1540	5/16" x 3/4" Carriage Bolt	4	
38	A22698	5/16" Flange Nut	4	
39	5CS43781	1/4" x 4" J-Bolt	1	
40	03H1701	1/4" x 3/4" Carriage Bolt	9	
41	5CS43398	Lynch Pin	3	
42	5CS43991	Frame Front Brace	1	
43	5CS43621	Triple Control Mount WA	1	
44	5CS65074	M8 X 15mm Hex Bolt	2	
-	5CS43992	FW Tank Strap	1	Not Illustrated

6 Roller PTO Pump

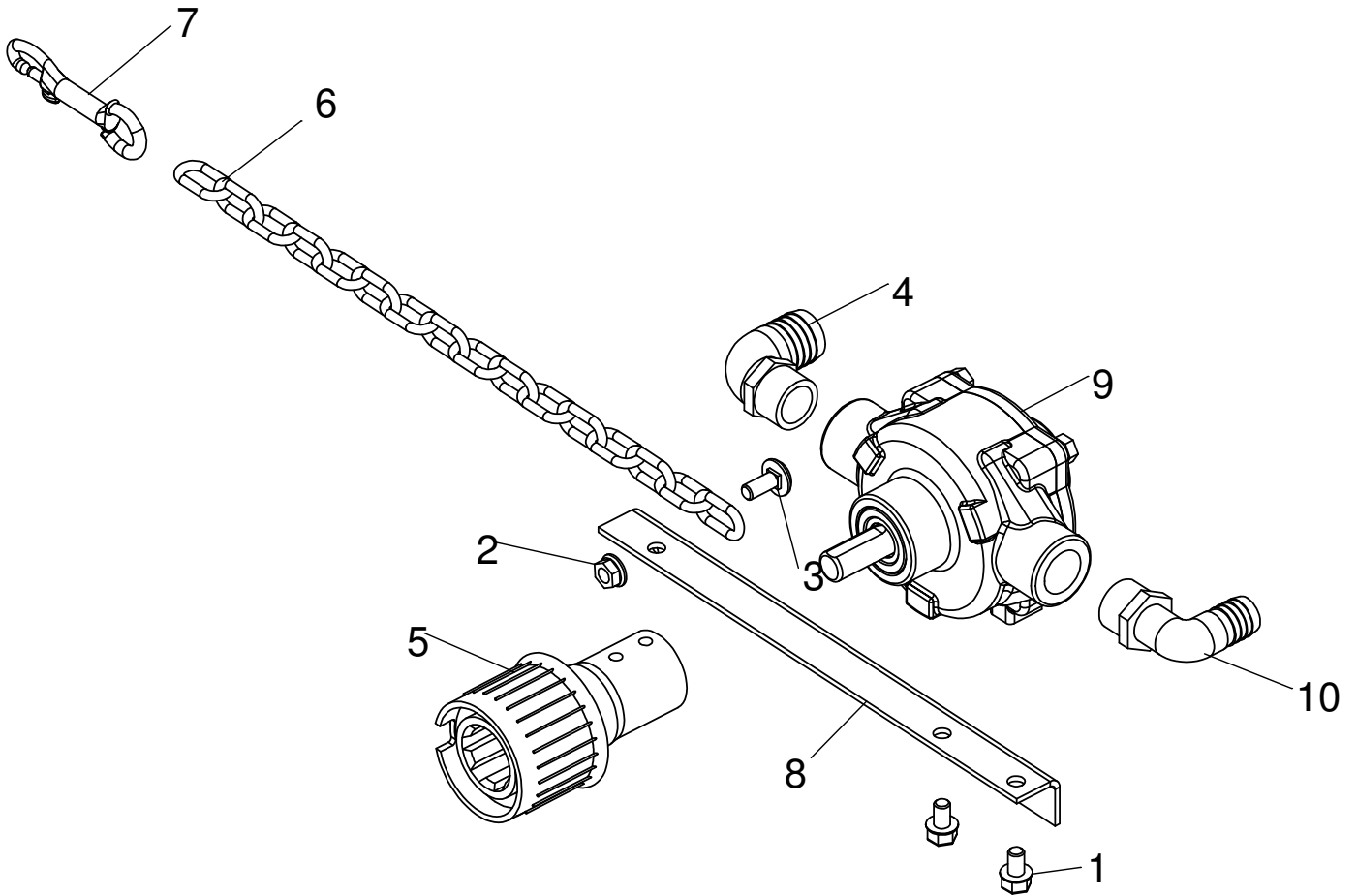

ITEM NO.	PART NUMBER	DESCRIPTION	QTY.	Note
1	N167649	5/16" x 1/2" Flange Bolt	2	
2	A22698	5/16" Flange Nut	1	
3	03H1540	5/16" x 3/4" Carriage Bolt	1	
4	5CS43638	Elbow 3/4" MP - 1" barb	1	
5	5CS43639	PTO Quick Connect Adapter	1	
6	5CS50268	Chain 2/0 - 1.5 ft	1	
7	5CS43650	Chain Latch	1	
8	5CS43622	Pump Mount Angle	1	
9	5CS43637	Pump Cast 6 Roller	1	
9	5CS43649	Pump Silver Series 6 Roller	1	
10	5CS43633	Elbow 3/4" MP - 3/4" barb	1	

7 Roller PTO Pump

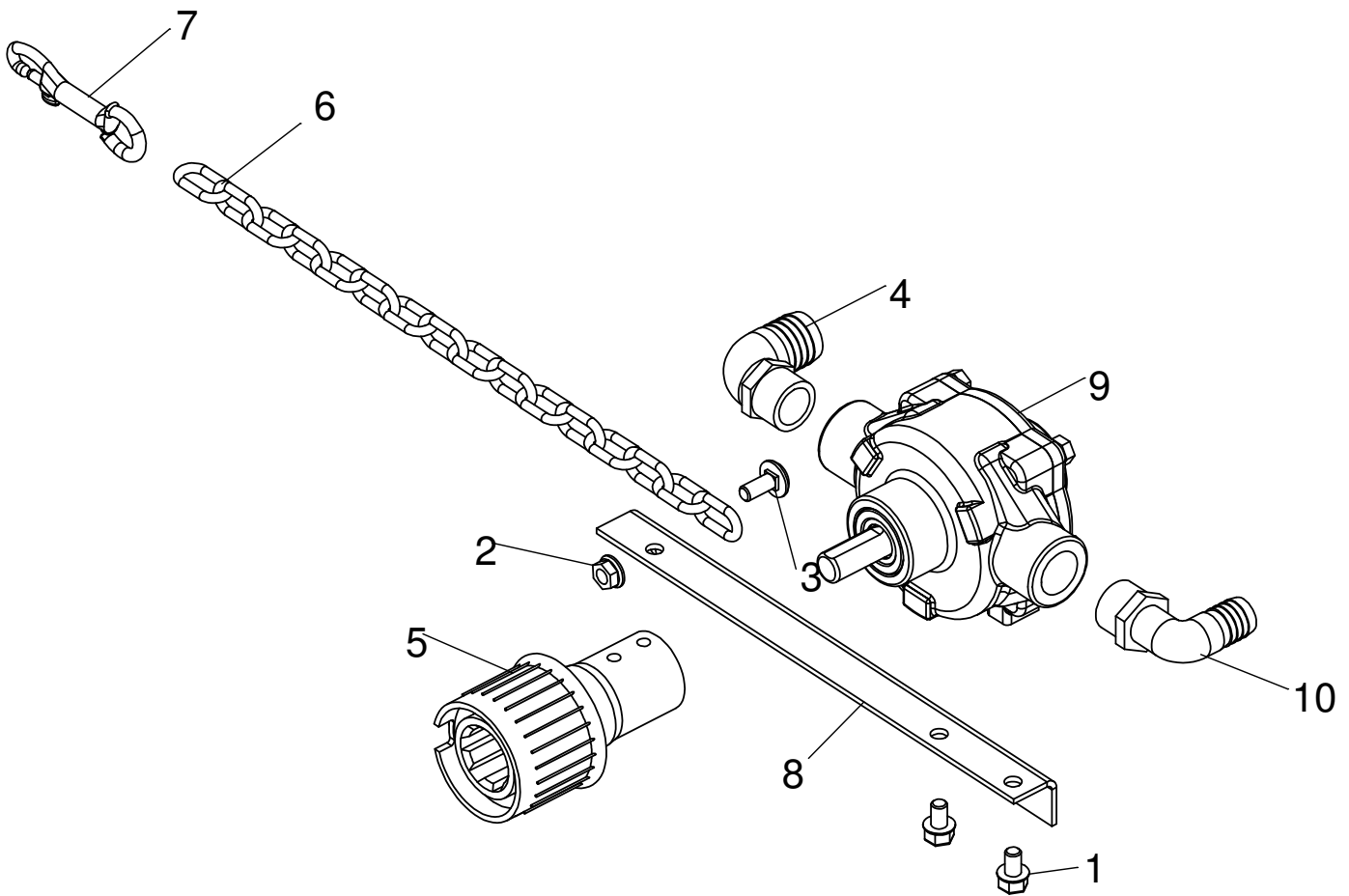

ITEM NO.	PART NUMBER	DESCRIPTION	QTY.	Note
1	N167649	5/16" x 1/2" Flange Bolt	2	
2	A22698	5/16" Flange Nut	1	
3	03H1540	5/16" x 3/4" Carriage Bolt	1	
4	5CS43638	Elbow 3/4" MP - 1" barb	1	
5	5CS43787	PTO Quick Connect Adapter	1	
6	5CS50268	Chain 2/0 - 1.5 ft	1	
7	5CS43650	Chain Latch	1	
8	5CS43622	Pump Mount Angle	1	
9	5CS43786	Pump Cast 7 Roller	1	
9	5CS43788	Pump Silver Series 7 Roller	1	
10	5CS43633	Elbow 3/4" MP - 3/4" barb	1	

18' Folding Boom

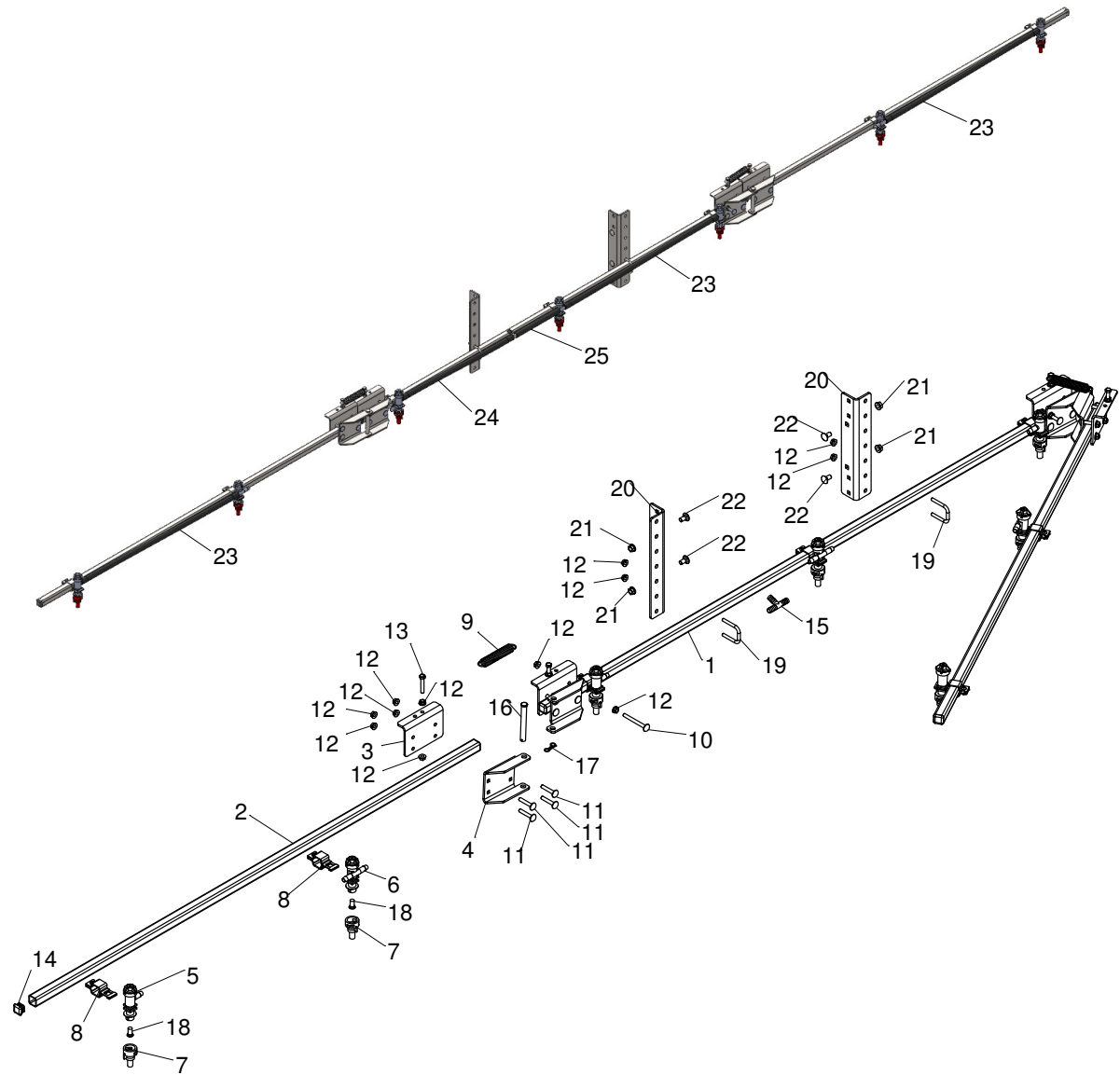

ITEM NO.	PART NUMBER	DESCRIPTION	QTY.	Note
1	5CS43644	Center Boom Tube 72"	1	
2	5CS43646	Side Boom Tube 60"	2	
3	5CS43616	Boom Hinge Backing Plate	4	
4	5CS43862	Boom Hinge Bracket	4	
5	5CS43658	Nozzle Body Single Hose 1/2"	4	
6	5CS43595	Nozzle Body Dual Hose 1/2"	3	
7	5CS43843	Air Induction Spray Tip 0.4 gpm	7	
8	5CS43598	Square Tube Clamp 1"	7	

18' Folding Boom

ITEM NO.	PART NUMBER	DESCRIPTION	QTY.	Note
9	5CS43403	Spring 3/4" x 3-3/4" x .105"	2	
10	03H1506	5/16" x 3" Carriage Bolt	2	
11	03H2209	5/16" x 1-3/4" Carriage Bolt	14	
12	A22698	5/16" Flange Nut	30	
13	5CS65090	5/16" x 1-3/4" Hex Bolt	4	
14	5CS43401	Plastic End Cap 1"	6	
15	5CS43420	Tee 1/2" Barb	1	
16	5CS50120	1/2"x4" Clevis Pin	2	
17	5CS50237	Bowtie Clip 1/2"	2	
18	5CS43411	Spray Tip Screen	7	
19	5CS43315	5/16" x 1-3/4" Square U-Bolt	2	
20	5CS43970	Boom Bracket	2	
21	E55662	3/8" Flange Nut	4	
22	5CS65081	3/8" x 3/4" Carriage Bolt	4	
23		1/2" Hose	3	CTL 29", MF 5CS43418
24		1/2" Hose	1	CTL 22.25", MF 5CS43418
25		1/2" Hose	1	CTL 6", MF 5CS43418
-	5CS43652	Hose Clamp Screw Type 3/8" - 1/2"	10	Not Illustrated

24' Folding Boom

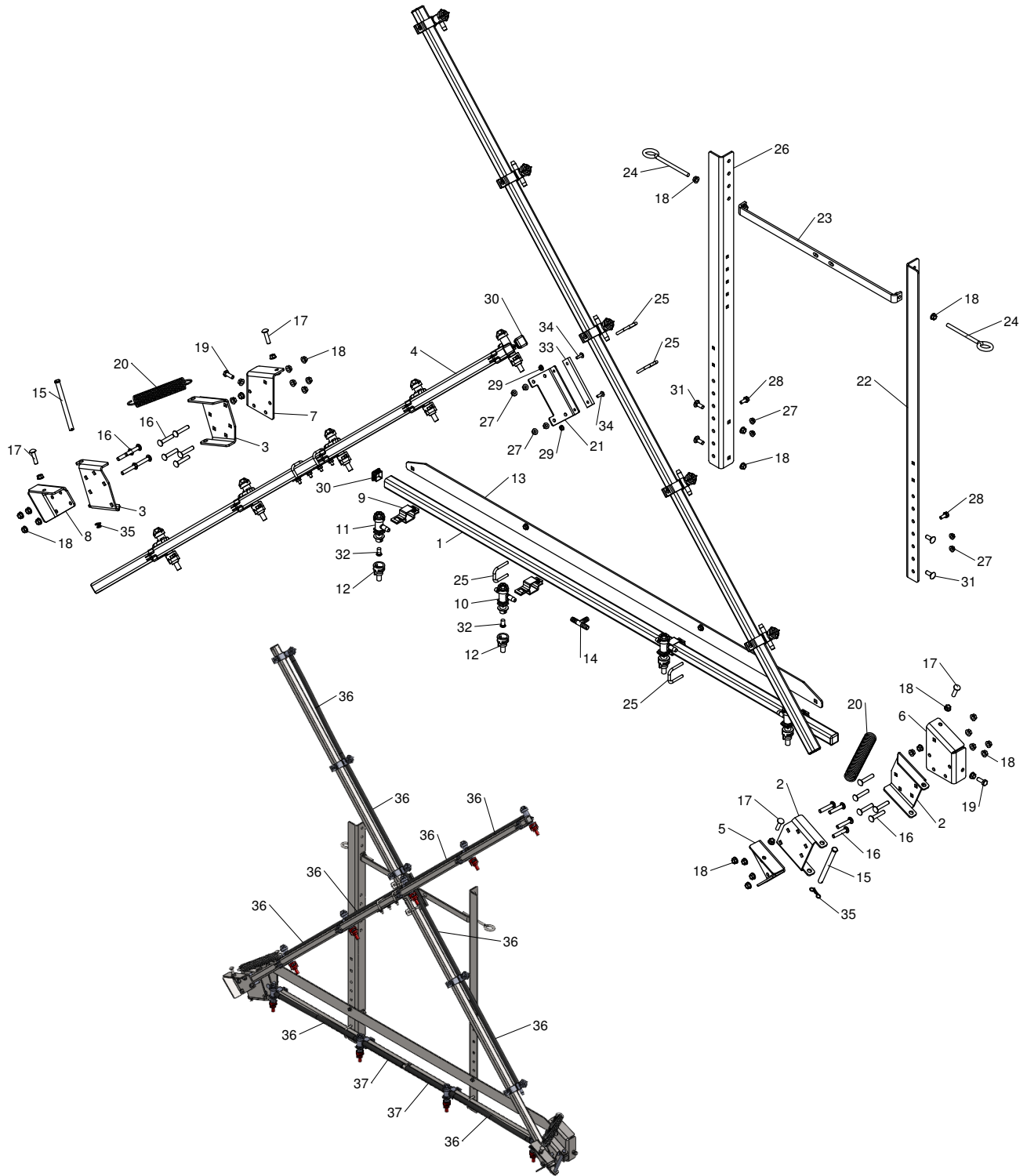

24' Folding Boom

ITEM NO.	PART NUMBER	DESCRIPTION	QTY.	Note
1	5CS43751	Center Boom Tube 72"	1	
2	5CS43727	Boom Hinge Right	2	
3	5CS43728	Boom Hinge Left	2	
4	5CS43752	Side Boom Tube 96"	2	
5	5CS43730	Boom Hinge Backing Plate Outside RH	1	
6	5CS43729	Boom Hinge Backing Plate Inside RH	1	
7	5CS43731	Boom Hinge Backing Plate Inside LH	1	
8	5CS43732	Boom Hinge Backing Plate Outside LH	1	
9	5CS43737	1-1/4" Sq Boom Clamp	14	
10	5CS43595	Nozzle Body Dual Hose 1/2"	10	
11	5CS43658	Nozzle Body Single Hose 1/2"	4	
12	5CS43843	Air Induction Spray Tip 0.4 gpm	14	
13	5CS43735	Boom Brace	1	
14	5CS43420	Tee 1/2" Barb	1	
15	5CS43750	1/2" x 6" Clevis Pin	2	
16	5CS65082	3/8" x 2" Carriage Bolt	18	
17	03H1495	3/8" x 1-1/2" Carriage Bolt	4	
18	E55662	3/8" Flange Nut	42	
19	5CS65088	3/8" x "1 Hex Bolt	2	
20	5CS43749	Spring 1-1/4" x 6-1/2" x .162"	2	
21	5CS43761	Boom Stop Bracket	2	
22	5CS43763R	Boom Angle RH	1	
23	5CS43734	Bottom Brace	1	
24	5CS43768	Eyebolt 3/8" x 5"	2	
25	5CS43315	5/16" x 1-3/4" Square U-Bolt	6	
26	5CS43763L	Boom Angle LH	1	
27	A22698	5/16" Flange Nut	14	
28	5CS65007	5/16" x 3/4" Flange Bolt	2	
29	N10217	1/4" Flange Nut	4	
30	5CS43757	Plastic End Cap 1-1/4"	6	
31	03H1500	3/8" x 1" Carriage Bolt	4	
32	5CS43411	Spray Tip Screen	14	
33	5CS43993	Rubber 5/16" x 1-1/4" x 6"	2	

24' Folding Boom

ITEM NO.	PART NUMBER	DESCRIPTION	QTY.	Note
34	5CS65016	1/4" x 3/4" truss head machine screw	4	
35	5CS50237	Bowtie Clip 1/2"	2	
36		1/2" Hose	10	CTL 19", MF 5CS43418
37		1/2" Hose	2	CTL 9.25", MF 5CS43418
-	5CS43652	Hose Clamp Screw Type 3/8" - 1/2"	27	Not Illustrated
-	5CS43767	3/8" Hollow braid rope, 18ft	2	Not Illustrated
-	5CS43772	S-hook 2" heavy duty	2	Not Illustrated

30' Folding Boom

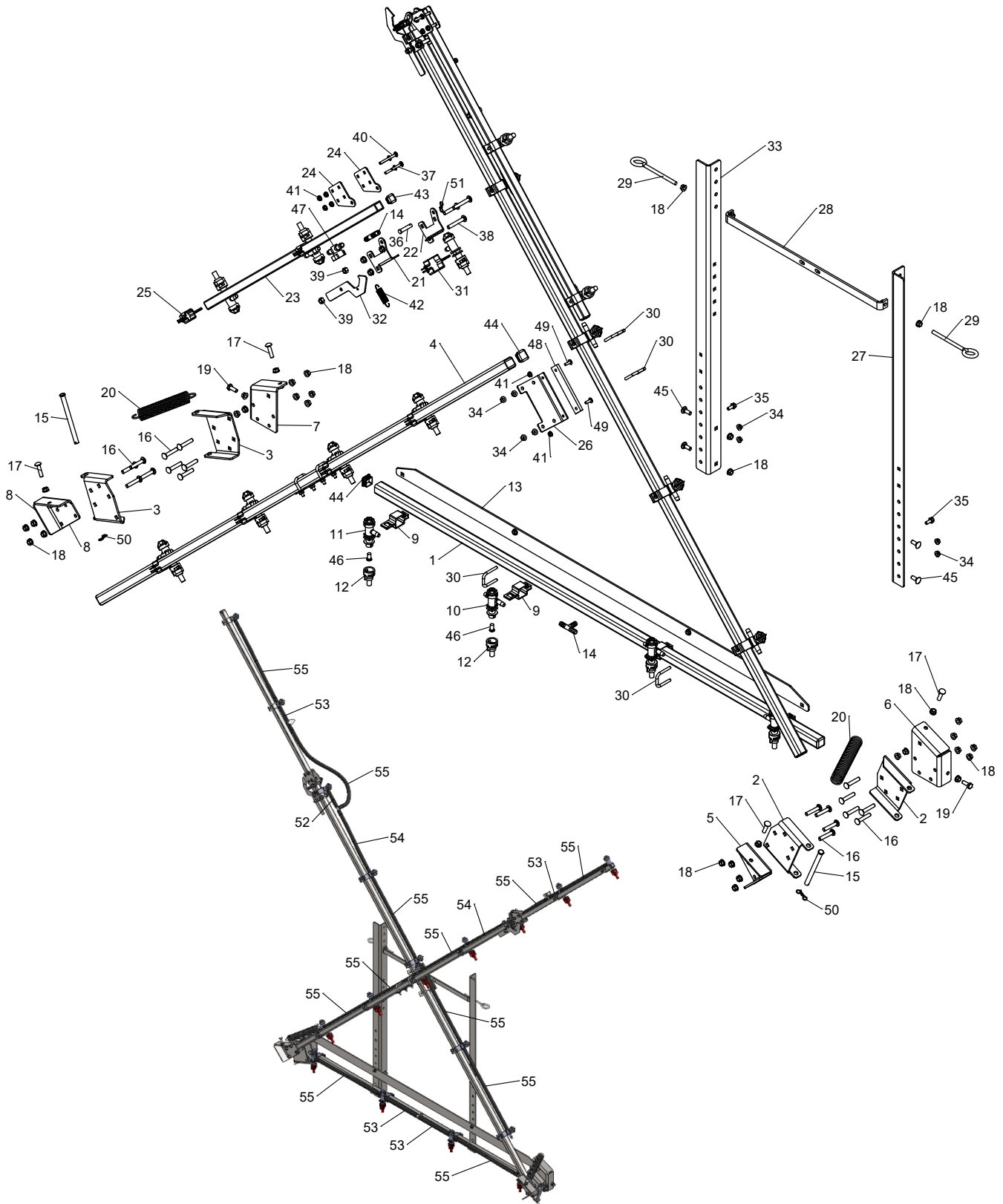

30' Folding Boom

ITEM NO.	PART NUMBER	DESCRIPTION	QTY.	Note
1	5CS43751	Center Boom Tube 72"	1	
2	5CS43727	Boom Hinge Right	2	
3	5CS43728	Boom Hinge Left	2	
4	5CS43752	Side Boom Tube 96"	2	
5	5CS43730	Boom Hinge Backing Plate Outside RH	1	
6	5CS43729	Boom Hinge Backing Plate Inside RH	1	
7	5CS43731	Boom Hinge Backing Plate Inside LH	1	
8	5CS43732	Boom Hinge Backing Plate Outside LH	1	
9	5CS43737	1-1/4" Sq Boom Clamp	12	
10	5CS43595	Nozzle Body Dual Hose 1/2"	12	
11	5CS43658	Nozzle Body Single Hose 1/2"	6	
12	5CS43843	Air Induction Spray Tip 0.4 gpm	18	
13	5CS43735	Boom Brace	1	
14	5CS43420	Tee 1/2" Barb	3	
15	5CS43750	1/2" x 6" Clevis Pin	2	
16	5CS65082	3/8" x 2" Carriage Bolt	20	
17	03H1495	3/8" x 1-1/2" Carriage Bolt	4	
18	E55662	3/8" Flange Nut	48	
19	5CS65088	3/8" x "1 Hex Bolt	2	
20	5CS43749	Spring 1-1/4" x 6-1/2" x .162"	2	
21	5CS43758	Boom Extension Hinge Inner	2	
22	5CS43759	Boom Extension Hinge Outer	2	
23	5CS60082	Boom Extension Tube 40"	2	
24	5CS43760	Boom Extension Hinge Plate	4	
25	5CS43598	Square Tube Clamp 1"	4	
26	5CS43761	Boom Stop Bracket	2	
27	5CS43763R	Boom Angle RH	1	
28	5CS43734	Bottom Brace	1	
29	5CS43768	Eyebolt 3/8" x 5"	2	
30	5CS43315	5/16" x 1-3/4" Square U-Bolt	6	
31	5CS43773	1-1/2" Sq Boom Clamp	2	
32	5CS43816	Boom Extension Latch	2	
33	5CS43763L	Boom Angle LH	1	

30' Folding Boom

ITEM NO.	PART NUMBER	DESCRIPTION	QTY.	Note
34	A22698	5/16" Flange Nut	14	
35	5CS65007	5/16" x 3/4" Flange Bolt	2	
36	5CS50231	3/8" x 1-3/4" Clevis Pin	2	
37	03H1810	1/4" x 1-1/2" Carriage Bolt	6	
38	5CS65052	3/8" x 2-1/2" Carriage Bolt	4	
39	T11234	3/8" Nylock Stover Nut	4	
40	5CS65158	1/4" x 2-1/2" Carriage Bolt	2	
41	N10217	1/4" Flange Nut	12	
42	5CS43817	Spring 2-1/2" x .625" x .075"	2	
43	5CS43401	Plastic End Cap 1"	4	
44	5CS43757	Plastic End Cap 1-1/4"	6	
45	03H1500	3/8" x 1" Carriage Bolt	4	
46	5CS43411	Spray Tip Screen	18	
47	5CS43736	In-line Valve 1/2"	2	
48	5CS43993	Rubber 5/16" x 1-1/4" x 6"	2	
49	5CS65016	1/4" x 3/4" Truss Head Bolt	4	
50	5CS50237	Bowtie Clip 1/2"	2	
51	5CS43624	Small Bowtie Clip	2	
52		1/2" Hose	2	CTL 3.5", MF 5CS43418
53		1/2" Hose	4	CTL 9.25", MF 5CS43418
54		1/2" Hose	2	CTL 16", MF 5CS43418
55		1/2" Hose	12	CTL 19", MF 5CS43418
-	5CS43652	Hose Clamp Screw Type 3/8" - 1/2"	43	Not Illustrated
-	5CS43767	3/8" Hollow braid rope, 18ft	2	Not Illustrated
-	5CS43772	S-hook 2" heavy duty	2	Not Illustrated

Boomless 30' Spray

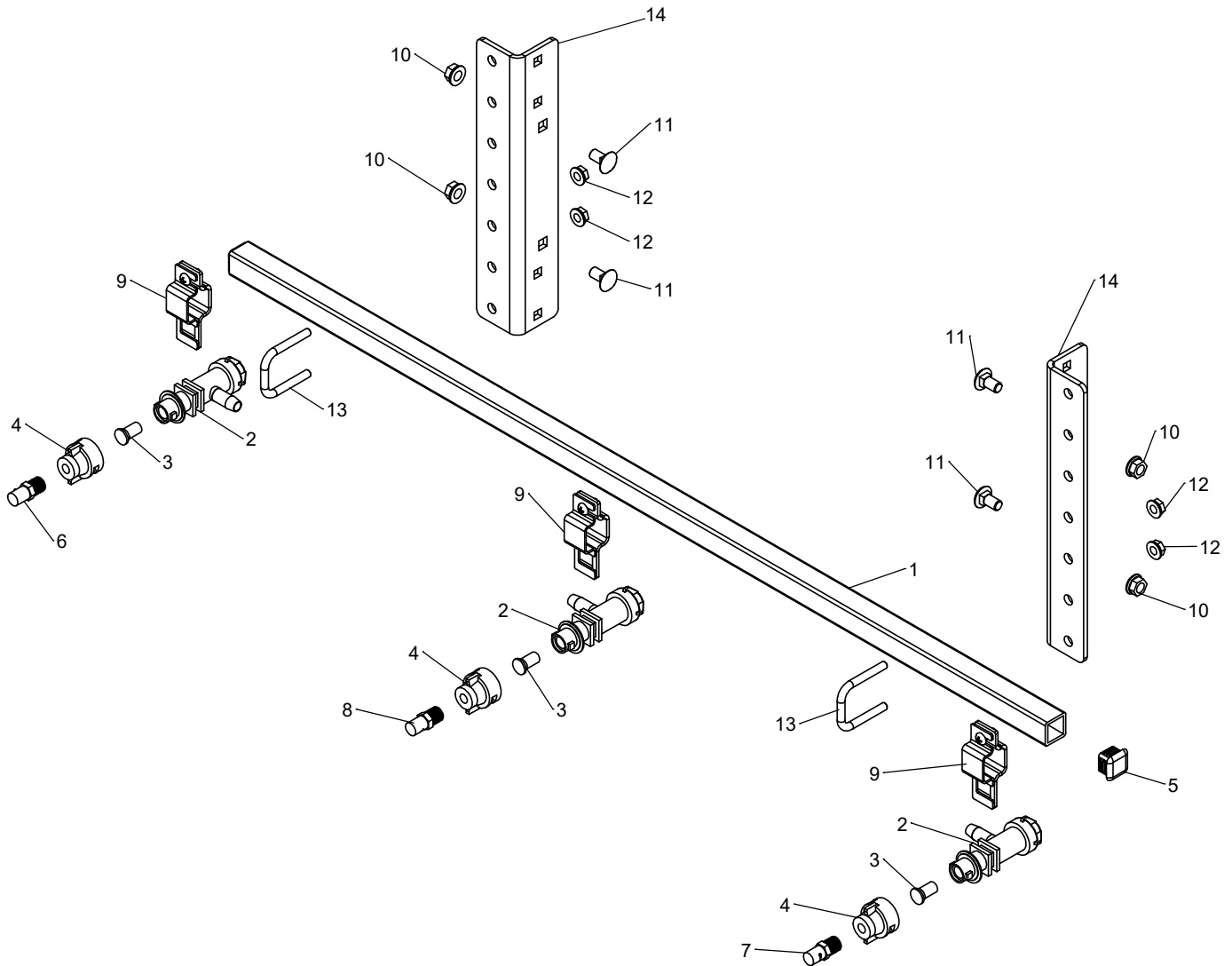

ITEM NO.	PART NUMBER	DESCRIPTION	QTY.	Note
1	5CS60082	Boom Tube 40"	1	
2	5CS43658	Nozzle Body Single Hose 1/2"	3	
3	5CS43411	Spray Tip Screen	3	
4	5CS43599	Spray Fitting Cap (threaded)	3	
5	5CS43401	Plastic End Cap 1"	2	
6	5CS43775	Boomless Flat Spray Tip Left	1	
7	5CS43774	Boomless Flat Spray Tip Right	1	
8	5CS43809	Boomless Flat Spray Tip Center	1	
9	5CS43598	Square Tube Clamp 1"	3	
10	E55662	3/8" Flange Nut	4	
11	5CS65081	3/8" x 3/4" Carriage Bolt	4	

Boomless 30' Spray

ITEM NO.	PART NUMBER	DESCRIPTION	QTY.	Note
12	A22698	5/16" Flange Nut	4	
13	5CS43315	5/16" x 1-3/4" Square U-Bolt	2	
14	5CS43970	Boom Bracket	2	

On-Highway Kit

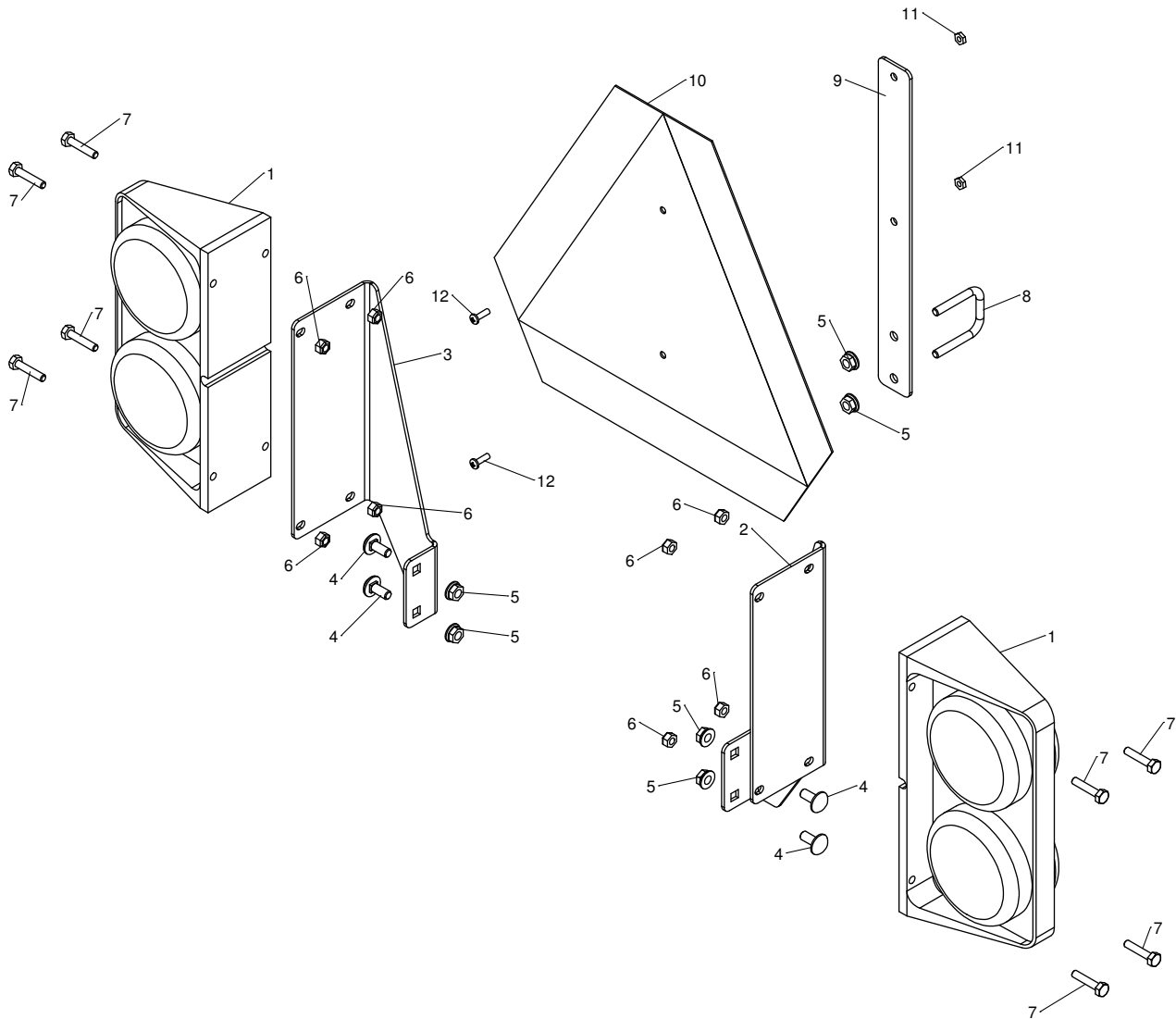

ITEM NO.	PART NUMBER	DESCRIPTION	QTY.	Note
1	5CS50934	Rear Light Kit - Includes Right and Left Assemblies and Harness	1	
2	5CS43968	Light Bracket RH	1	
3	5CS43969	Light Bracket LH	1	
4	03H1540	5/16" x 3/4" Carriage Bolt	4	
5	A22698	5/16" Flange Nut	6	
6	5CS65017	1/4" Nylock Nut	8	
7	5CS65184	1/4" x 1-1/4" Bolt	8	
8	5CS43315	5/16" x 1-3/4" Square U-Bolt	1	
9	5CS43614	SMV Bracket	1	

On-Highway Kit

ITEM NO.	PART NUMBER	DESCRIPTION	QTY.	Note
10	5CS43647	SMV Sign	1	
11	5CS65051	#10-24 Nut	2	
12	5CS65258	#10-24 x 3/8" Phillips Pan Head Screw	2	
-	5CS43983	Push in Cable Clamp with Wire Ties	8	Not Illustrated

100 ft Hose Reel (110/150)

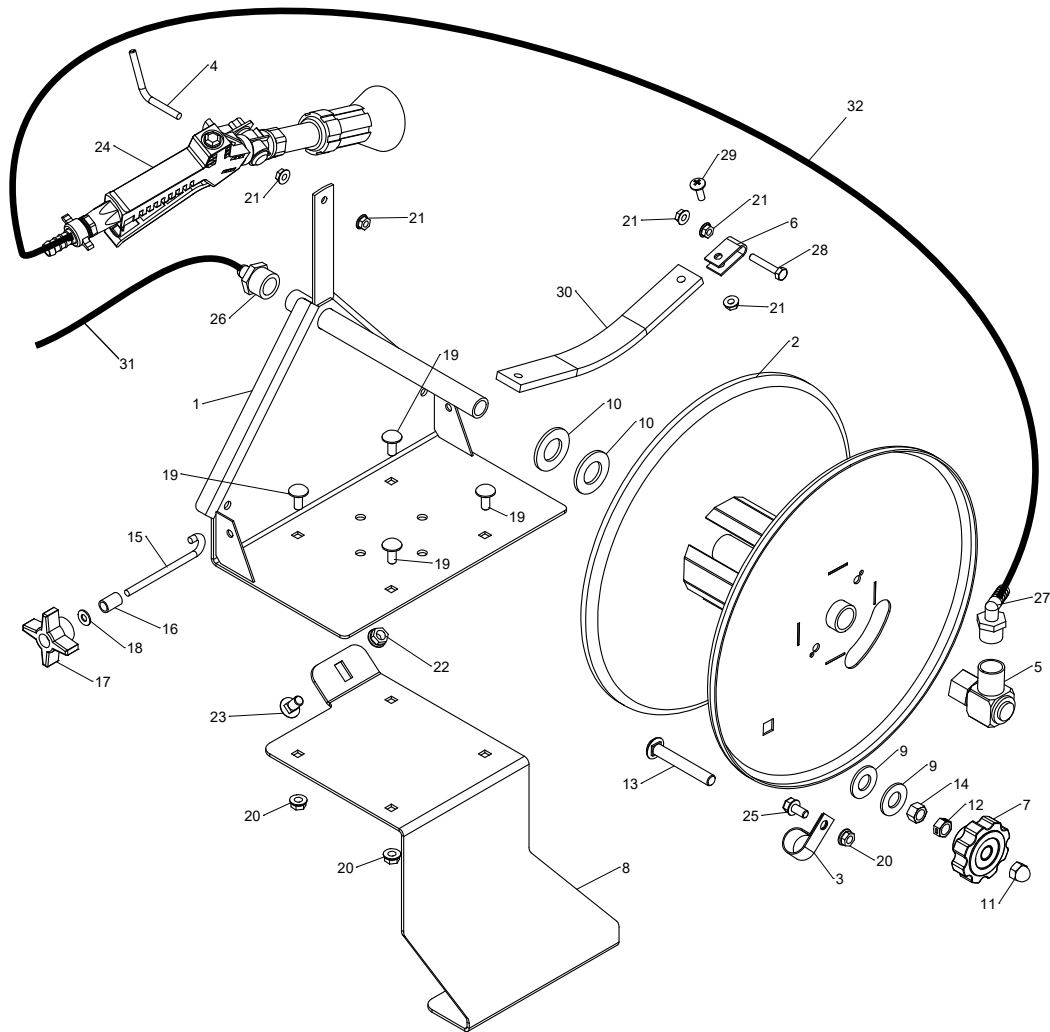

ITEM NO.	PART NUMBER	DESCRIPTION	QTY.	Note
1	5CS43686	Hose Reel Spindle	1	
2	5CS43687	Hose Reel	1	
3	5CS43663	Hose Holder 1/2"	1	
4	5CS62008	1/4" Bent Pin	1	
5	5CS43782	Swivel 1/2fpt, Elbow	1	
6	5CS50245	Rubber Chain Clamp	1	
7	5CS43783	Swivel Knob	1	
8	5CS43967	Hose Reel Bracket	1	
9	A110615	5/8" SAE Washer	2	
10	5CS65161	7/8" SAE Washer	2	
11	5CS65162	7/16" Acorn Nut	1	

100 ft Hose Reel (110/150)

ITEM NO.	PART NUMBER	DESCRIPTION	QTY.	Note
12	5CS65163	7/16" Center Lock Nut	1	
13	03H1705	7/16 x 3 Carriage Bolt	1	
14	14H849	7/16" Hex Nut	1	
15	5CS43781	1/4" x 4" J-Bolt	1	
16	5CS43725	Spacer	1	
17	5CS43810	1/4" Plastic Knob	1	
18	5CS65154	1/4" Washer	1	
19	03H1540	5/16 x 3/4 Carriage Bolt	4	
20	A22698	5/16 Flange Nut	5	
21	N10217	1/4" Flange Nut	5	
22	E55662	3/8 Flange Nut	1	
23	5CS65081	3/8 x 3/4 Carriage Bolt	1	
24	5CS43435	HP Handgun	1	
25	T58694	5/16 x 5/8 Flange Bolt	1	
26	5CS43588	1/2" Barb x 1/2NPT F, 90deg	1	
27	5CS43803	Elbow 1/2" Barb x 1/2NPT	1	
28	TCU38060	1/4"x 1-1/2" Bolt	1	
29	5CS65016	1/4 x 3/4 Truss Head Bolt	1	
30	5CS43988	Rubber 5/16" x 1-1/4" x 10"	1	
31		1/2" Hose	1	CTL 36", MF 5CS43418
32		1/2" Hose	1	CTL 1200", MF 5CS43418
-	5CS43652	Hose Clamp Screw Type 3/8" - 1/2"	4	Not Illustrated

CAT 2 Pin Kit

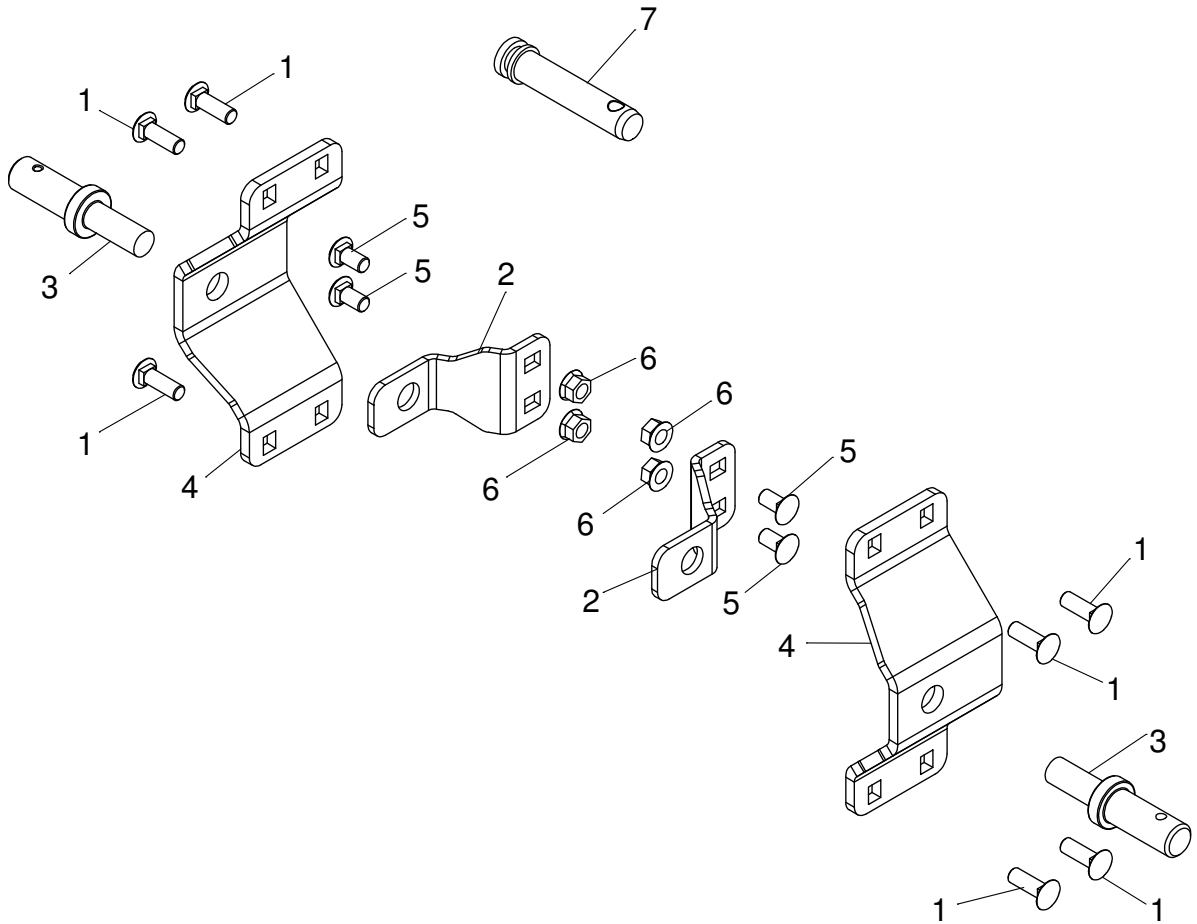

ITEM NO.	PART NUMBER	DESCRIPTION	QTY.	Note
1	5CS65272	1/2" x 1-1/2" Carriage Bolt	8	
2	5CS43963	CAT 2 Pin Brace	2	
3	5CS61513	CAT 2 Side Pin	2	
4	5CS43962	CAT 2 Pin Bracket	2	
5	5CS65044	1/2" x 1" Carriage Bolt	4	
6	5CS65037	1/2" Flange Nut	4	
7	5CS61514	CAT 2 Top Link Pin	1	

BOLT TORQUE CHART

- Torque values listed are for general use only, based on the strength of the bolt or screw. DO NOT use these values if a different torque value or tightening procedures is given for a specific application. For plastic insert or crimped steel type lock nuts, for stainless steel, or for nuts on u-bolts, see the tightening instructions for the specific application.
- Fasteners must always be replaced with the same grade as specified in the manual parts list.
- Shear bolts are designed to fail under predetermined loads, always replace shear bolts with identical grades.
- Make sure fasteners threads are clean and start thread engagement properly.

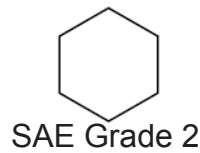
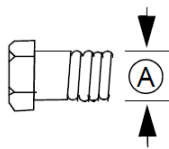

Diameter (A) (Inches)	Torque Values (Dry)					
	SAE Grade 2		SAE Grade 5		SAE Grade 8	
	N-m	lb-ft	N-m	lb-ft	N-m	lb-ft
1/4	7.4	5.5	12	9	17	12.5
5/16	15	11	24	18	35	26
3/8	27	20	45	33	62	46
7/16	43	32	70	52	102	75
1/2	68	50	108	80	156	115
9/16	95	70	156	115	217	160
5/8	136	100	217	160	305	225
3/4	238	175	380	280	540	400
7/8	238	175	615	455	870	640

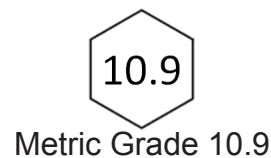
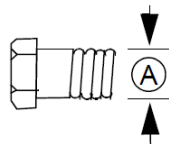

Diameter (A) (millimeters)	Torque Values (Dry)			
	Grade 8.8		Grade 10.9	
	N-m	lb-ft	N-m	lb-ft
M6	11.3	8.3	16.5	12.2
M8	27.5	20.3	40	29.5
M10	55	40	80	59
M12	95	70	140	105
M14	150	110	220	165
M16	240	175	350	255

**THIS PAGE
INTENTIONALLY LEFT
BLANK**

**THIS PAGE
INTENTIONALLY LEFT
BLANK**

**THIS PAGE
INTENTIONALLY LEFT
BLANK**

PART NUMBER
5CS201115OM

COPYRIGHT © 2020 Superior Tech Inc. Lancaster, PA All rights reserved

