

OPERATOR'S MANUAL

# LIQUID SPRAYER

**LS2004**

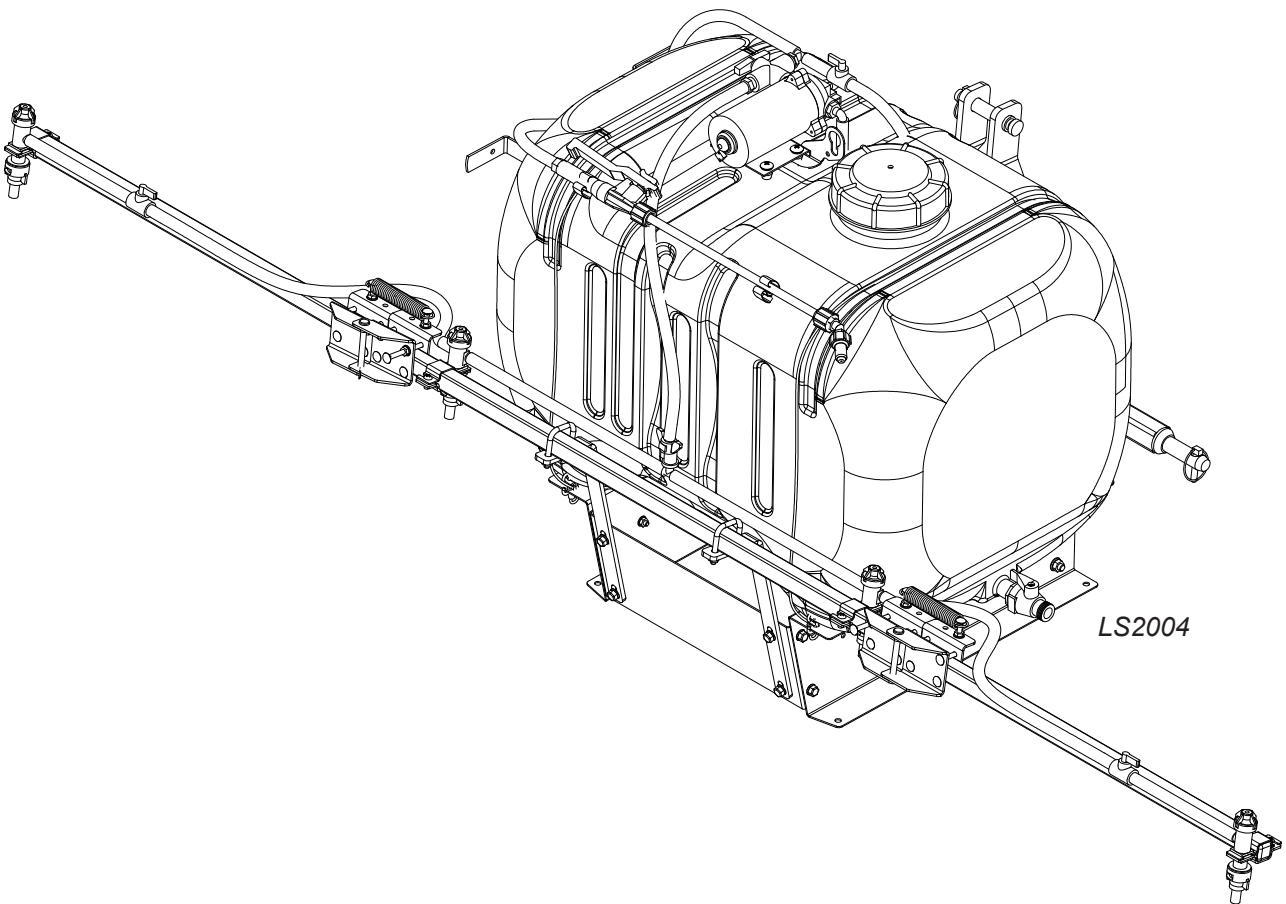

**FRONTIER™**

**TO THE DEALER:**

Assembly and proper installation of this product is the responsibility of the Frontier dealer. Read manual instructions and safety rules. Make sure all items on the Dealer’s Pre-Delivery and Delivery Check Lists in the Operator’s Manual are completed before releasing equipment to the owner.

**TO THE OWNER:**

Read this manual before operating your Frontier equipment. The information presented will prepare you to do a better and safer job. Keep this manual handy for ready reference. Require all operators to read this manual carefully and become acquainted with all the adjustment and operating procedures before attempting to operate. Replacement manuals can be obtained from your selling dealer.

The equipment you have purchased has been carefully engineered and manufactured to provide dependable and satisfactory use. Like all mechanical products, it will require cleaning and upkeep. Lubricate the unit as specified. Observe all safety information in this manual and safety decals on the equipment.

For service, your authorized Frontier dealer has trained mechanics, genuine Frontier service parts, and the necessary tools and equipment to handle all your needs.

Use only genuine Frontier service parts. Substitute parts will void the warranty and may not meet standards required for safe and satisfactory operation. Record the model number and serial number of your equipment in the spaces provided:

**Model:** \_\_\_\_\_ **Date of Purchase:** \_\_\_\_\_  
**Serial Number: (see Safety Decal section for location)** \_\_\_\_\_

Provide this information to your dealer to obtain correct repair parts.

Throughout this manual, the term **NOTICE** is used to indicate that failure to observe can cause damage to equipment. The terms **CAUTION**, **WARNING** and **DANGER** are used in conjunction with the Safety-Alert Symbol, (a triangle with an exclamation mark), to indicate the degree of hazard for items of personal safety.



This is the safety alert symbol. It is used to alert you to potential physical injury hazards. Obey all safety messages that follow this symbol to avoid possible injury or death.



Indicates a hazardous situation that, if not avoided, will result in death or serious injury.



Indicates a hazardous situation that, if not avoided, could result in death or serious injury.



Indicates a hazardous situation that, if not avoided, could result in minor or moderate injury.

**IMPORTANT**  
or **NOTICE**

Is used to address practices not related to physical injury.

**NOTE**

Indicates helpful information.

# TABLE OF CONTENTS

<b>INTRODUCTION</b>	<b>4</b>
<b>SAFETY</b>	<b>5</b>
Safety and Instructional Labels	9
<b>ASSEMBLY</b>	<b>10</b>
<b>INSTALLATION</b>	<b>13</b>
<b>OPERATION</b>	<b>15</b>
<b>SERVICE</b>	<b>20</b>
<b>TROUBLESHOOTING</b>	<b>22</b>
<b>SPECIFICATIONS</b>	<b>23</b>
Tractor Ballasting	24
<b>Parts Diagrams</b>	<b>25</b>
<b>Bolt Torque Chart</b>	<b>39</b>

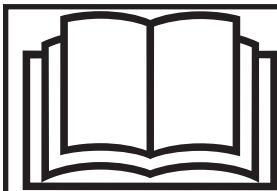

This Operator's Manual should be regarded as part of the machine. Suppliers of both new and second-hand machines must make sure that the manual is provided with the machine.

# GENERAL INFORMATION

**READ THIS MANUAL** carefully to learn how to operate and service your machine correctly. Failure to do so could result in personal injury or equipment damage. This manual and safety signs on your machine may also be available in other languages. (See your Frontier dealer to order.)

The illustrations and data used in this manual were current at the time of printing but, due to possible inline production changes, your machine may vary slightly in detail. We reserve the right to redesign and change the machines as may be necessary without notification.

**THIS MANUAL SHOULD BE CONSIDERED** a permanent part of your machine and should remain with the machine when you sell it.

**MEASUREMENTS** in this manual are given in both metric and customary U.S. unit equivalents. Use only correct replacement parts and fasteners. Metric and inch fasteners may require a specific metric or inch wrench.

**RIGHT-HAND AND LEFT-HAND** sides are determined by facing in the direction of forward travel.

**WARRANTY** is provided as part of Frontier's support program for customers who operate and maintain their equipment as described in this manual. The warranty is explained on the warranty certificate or statement which you should have received from your dealer.

This warranty provides you the assurance that Frontier will back its products where defects appear within the warranty period. In some circumstances, Frontier also provides field improvements, often without charge to the customer, even if the product is out of warranty.

Should the equipment be abused, or modified to change its performance beyond the original factory specifications, the warranty will become void and field improvements may be denied. Setting fuel delivery above specifications or otherwise overpowering machines will result in such action.

If you are not the original owner of this machine, it is in your interest to contact your local Frontier dealer to inform them of this unit's serial number. This will help Frontier notify you of any issues or product improvements.

# SAFETY

Read Safety in Machine Operator's Manual  
Read the general safety operating precautions in your machine operator's manual for additional safety information.

## Operate Safely

- Read the machine and attachment operator's manual carefully. Be thoroughly familiar with the controls and the proper use of the equipment. Know how to stop the machine and disengage the controls quickly.
  - Do not let children or an untrained person operate machine.
  - Make any necessary adjustments before you operate. Never attempt to make any adjustments while the engine is running, unless if recommended in adjustment procedure.
  - Take all possible precautions when leaving the machine unattended. Shut off the engine before making any repairs, adjustments, or inspections. Lower the attachment, lock the parking brake, stop the engine, and remove the key.
  - Look behind machine before you back up. Back up carefully.
  - Do not let anyone, especially children, ride on machine or attachment. Riders are subject to injury such as being struck by foreign objects and being thrown off. Riders may also obstruct the operator's view, resulting in the machine being operated in an unsafe manner.
  - Use only attachments and accessories approved by the manufacturer of this product.
  - If the machine vibrates abnormally, stop the engine and check immediately for the cause. Vibration is generally a warning of trouble.
  - Always refer to the Storage section of the operator's manual for important details if storing this product for a long period of time.
- Keep people and pets out of the work area. Stop machine if anyone enters the area.
  - If you hit an object, stop the machine and inspect it. Make repairs before you operate. Keep machine properly maintained and in good working order. Keep all shields and guards in place.
  - Always inspect the sprayer completely before and after each use. Before pressurizing the system, check to be sure all fittings and hoses are tightly installed. Be sure guards and shields are in good condition and fastened in place. Make any necessary adjustments before you operate.
  - Never use the sprayer during windy conditions.
  - Always release pressure in the system before filling, cleaning or servicing the sprayer.
  - Do not put nozzle tip or other sprayer parts to your lips to blow out dirt. Use compressed air.

## Parking Safely

1. Stop vehicle on a level surface, not on a slope.
2. Lock park brake.
3. Lower 3pt attachment to the ground.
4. Stop engine.
5. Remove key.
6. Before you leave the operator's seat, wait for engine and all moving parts to stop.

## Mix and Handle Chemicals Safely

- Wear full cover clothing and wear protective goggles and rubber gloves to protect yourself while handling chemicals
- Follow instructions on chemical container labels.
- Open all chemical containers carefully, using proper tools.
- Open, pour, weigh and mix chemicals in a well-ventilated area.

- Reserve all equipment used for the application of chemicals exclusively for that purpose.
- Prohibit all smoking, drinking and eating food in chemical-handling area.
- It is a good practice to take a soapy shower immediately after using the sprayer to apply chemicals.
- Wash all clothing worn when using chemicals separately in the laundry after spraying is completed.

### **Read Chemical Container Label**

- Chemicals can be dangerous. Improper selection or use can injure persons, animals, plants, soils or other property. Select the right chemical for the job and handle and apply with care.
- Read the instructions, precautions, and warnings on the container label before opening. Use the product strictly according to label directions for specific applications, in the amounts specified, at the times specified and only when needed.
- Keep the container closed tightly except when preparing the mix.
- Do not remove labels from chemical containers. Store all chemicals in their original containers.
- Do not mix chemicals unless stated on the container label.
- Store chemicals when not in use according to the container label.

### **Handle Chemical Products Safely**

- Direct exposure to hazardous chemicals can cause serious injury. Potentially hazardous chemicals used with Frontier equipment include pesticides, herbicides and fungicides.
- A Safety Data Sheet (SDS) provides specific details on chemical products: physical and health hazards, safety procedures, and emergency response techniques.

- The SDS should be obtained from the chemical dealer at the time of the chemical purchase.
- Check the SDS before beginning any job using a hazardous chemical. Know exactly what the risks are and how to do the job safely.
- Always wear recommended personal protection equipment.

### **Practice Safe Maintenance**

- Only qualified, trained adults should service this machine.
- Understand service procedure before doing work. Keep area clean and dry.
- Do not operate the engine in a confined space where dangerous carbon monoxide fumes can collect.
- Never lubricate, service or adjust the machine or attachment while it is moving. Keep safety devices in place and in working condition. Keep hardware tight.
- Keep hands, feet, clothing, jewelry, and long hair away from any moving parts, to prevent them from getting caught.
- Lower any attachment completely to the ground or to an existing attachment mechanical stop before servicing the attachment. Disengage all power and stop the engine. Lock park brake and remove the key. Let machine cool.
- Disconnect battery before making any repairs.
- Before servicing machine or attachment, carefully release pressure from any components with stored energy, such as hydraulic components and springs.
- Release hydraulic pressure by lowering attachment or cutting units to the ground or to a mechanical stop and move hydraulic control levers.

- Securely support any machine or attachment elements that must be raised for service work. Use jack stands or lock service latches to support components when needed.
- Never run engine unless park brake is locked.
- Keep all parts in good condition and properly installed. Fix damage immediately. Replace worn or broken parts. Replace all worn or damaged safety and instruction decals.
- Check all hardware at frequent intervals to be sure the equipment is in safe working condition.
- Do not modify machine or safety devices. Unauthorized modifications to the machine or attachment may impair its function and safety.
- Certain operating conditions may dictate that the operator and any passenger wear appropriate safety equipment while operating the vehicle. Be prepared for any existing and potential conditions before operating machine.
- Local safety or insurance regulations may require additional safety equipment such as eye protection or a hard hat.
- Always wear substantial footwear and long-legged pants. Do not operate the equipment when barefoot or wearing open sandals.
- Wear proper clothing and safety equipment while handling chemicals or using the sprayer. Refer to the SDS for the chemicals being used to be sure the proper personal protection equipment is being used.

### Transportation

- Use additional caution and reduce speed when under adverse surface conditions, turning, or on inclines.
- Do not operate or transport on steep slopes.
- Do not operate or transport equipment while under the influence of alcohol or drugs.
- Always comply with all state and local lighting and marking requirements.

### Storage

- Block equipment securely for storage.
- Keep children and bystanders away from storage area.

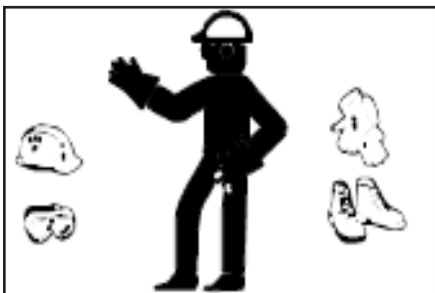

### Wear Appropriate Clothing

- Wear close fitting clothing and safety equipment appropriate for the job.

### Dispose of Chemicals Properly

- Proper disposal of excess spray material is very important. If you have excess tank solution, it is best to dilute it with water and apply it to the area you previously treated.
- Never dump solution into a drain or near a lake or stream.
- Chemicals containers should be triple-rinsed, with the rinse water added to the sprayer tank. Do not burn empty chemical containers. Dispose of containers at recycling centers.

### Handling Waste Product and Chemicals

Waste products, such as, used oil, fuel, coolant, brake fluid, and batteries, can harm the environment and people:

- Do not use beverage containers for waste fluids someone may drink from them.
- See your local Recycling Center or authorized dealer to learn how to recycle or get rid of waste products.

- A Safety Data Sheet (SDS) provides specific details on chemical products: physical and health hazards, safety procedures, and emergency response techniques. The seller of the chemical products used with your machine is responsible for providing the SDS for that product.





**SAFETY AND INSTRUCTIONAL LABELS**  
**ATTENTION! BECOME ALERT! YOUR SAFETY IS INVOLVED!**  
**Replace Damaged or Missing Labels Immediately!**



1 - PN 5CS50910

**CAUTION**

1. Read and understand the Operator's Manual before using.
2. Tractor cab may not provide sufficient protection. See Tractor's Operator's Manual.
3. Stay away from chemicals, spray, and drift.
4. Before servicing or filling sprayer, lower all equipment to the ground, set the park brake, stop the engine, and remove the key.
5. Keep hands, feet, hair, and clothing away from moving parts.
6. Clear the area of bystanders before extending or folding booms.
7. Do not allow riders.
8. Keep others away.

ST50910

2 - PN 5CS50927

**WARNING**



To avoid injury from chemical hazards due to skin contact, inhalation, and ingestion, wear personal protective equipment. Read and follow chemical manufacturer's labels and instructions.

ST50927

3 - 5CS50928

**LS2004 45 GALLON LIQUID SPRAYER**

Mfg Date: MM/DD/YYYY  
 Mass (Empty): 79 - 96 Lbs (36 - 44 Kg)  
 Mass (Laden): 496 - 513 Lbs (225 - 233 Kg)  
 Tank Volume: 45 Gal (170 L)  
 Max Working Pressure: 100 psi (6.9 Bar)

ST50928

4 - Serial Number Tag

**FRONTIER**

Serial Number  
 \*XXXXXXXXXXXXXXXXXXXX\*



45 GALLON LIQUID SPRAYER MODEL# LS2004

MADE IN USA  
 DEERE & COMPANY, MOLINE, ILLINOIS, USA

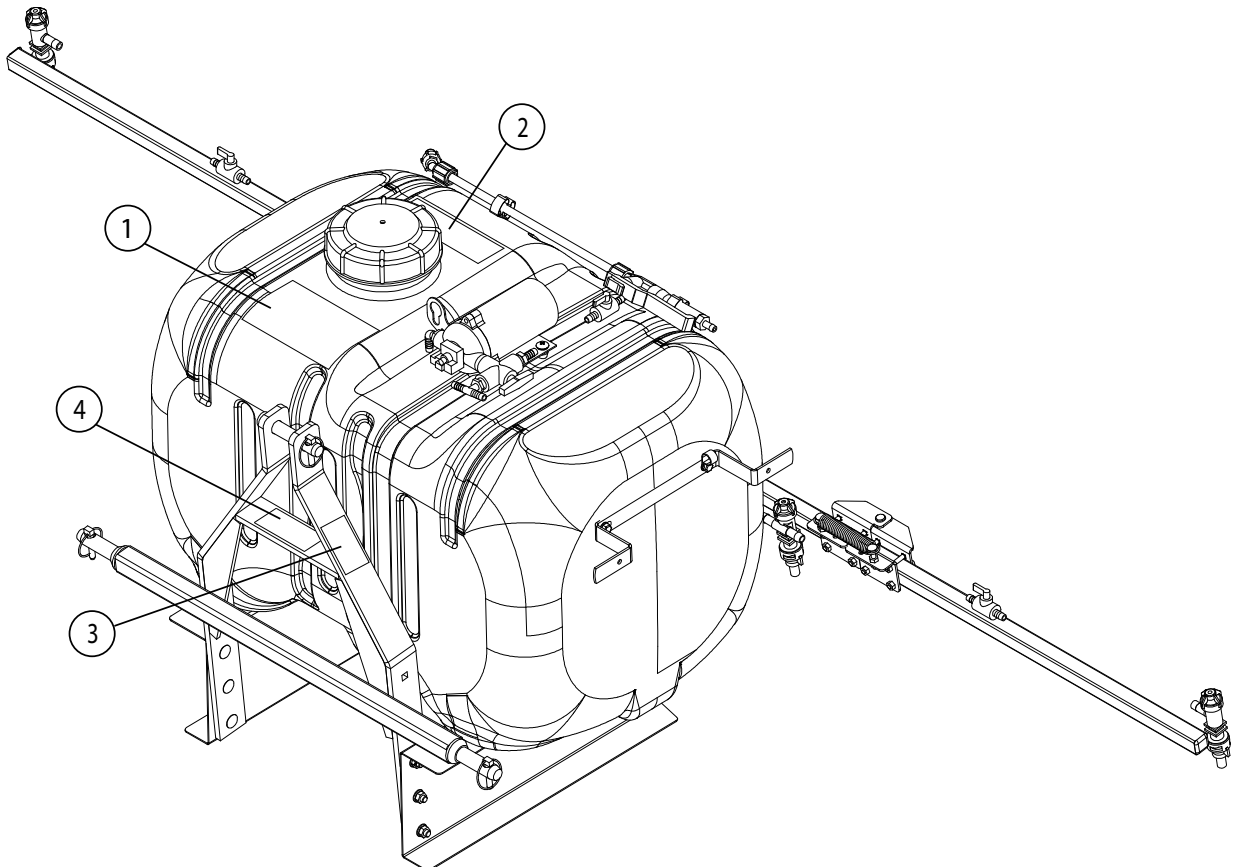

# ASSEMBLY

## Dealer Set-Up Instructions

Assembly of this equipment is the responsibility of the Frontier dealer. It should be delivered to the owner completely assembled and adjusted for normal operating conditions. In most cases the Sprayer will be shipped completely assembled with the only assembly being the boom.

### Remove Sprayer from Shipping Pallet

1. Remove plastic stretch wrap from sprayer and boom.
2. Remove hardware that used to secure sprayer to pallet and remove sprayer from pallet.
3. If options are supplied, remove these from the pallet.
4. Remove harnesses from inside of sprayer tank.

### Parts Included with Sprayer

Part Number	Description	Qty.
5CS50912	Battery Harness	1
5CS50913	Chassis Harness	1
5CS50914	Switch Harness	1
5CS50915	Sprayer Extension Harness	1
5CS48616	Fir Tree Clip with Wire Tie	1
5CS43986	10" Wire Tie	10
5CS43984	Edge Clip with Wire Tie	1
5CS43985	24.75mm Grommet	1

## Preparing Vehicle

### Install Wiring Harness



**CAUTION: Avoid Injury!** Refer to the Safety Section of this manual and the Tractor Operator's Manual for safe maintenance procedures.

*NOTE: For installation on 2032R, 2038R, 3E or 3D Series tractors, please see instructions below*

1. Remove LH side engine cover and operator station platform in order to improve access to main chassis harness and ensure safe and proper harness routing. LH pedestal cover may be removed for improved access for 2032R, 2038R, 3D and 3E series.
2. Starting with the Battery Harness (5CS50912), route harness along positive battery cable and secure with wire tie near yellow tape. For 1023E, 1025R and 2025R tractors, skip to Step 4.

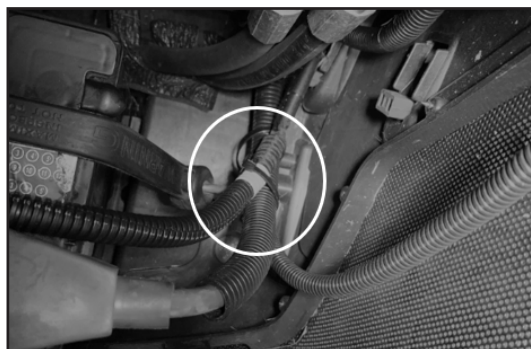

### For 2032R, 2038R, 3D and 3E Series Tractors:

3. Retain harness using edge clip (5CS43984) from rear edge of battery tray.

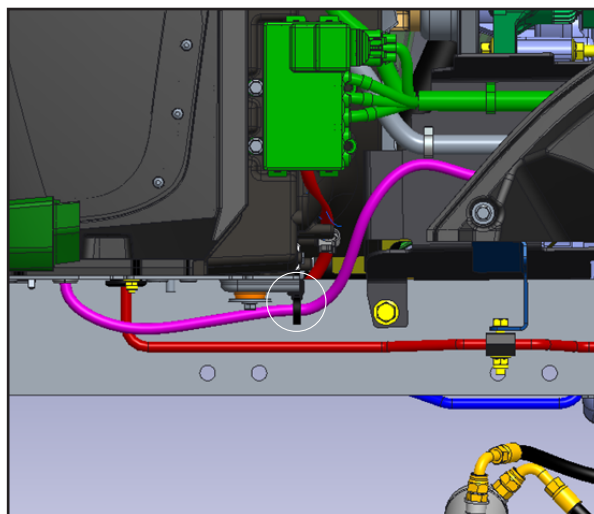

- Route chassis harness (5CS50913) starting from the battery harness to the right rear of the tractor near the ROPS. Follow the main chassis harness under the operator station platform and retain the chassis harness to the main chassis harness at least every 10" and on both sides of a bend.

**NOTICE:** Wire routing must ensure no wires/ conduit are in direct contact with moving parts and/or high temperature components.

- Route switch harness (5CS50914) from the end of the chassis harness up the ROPS on the right hand side of the tractor.



- Secure the switch harness to the ROPS using the supplied fir tree clip.
- Route free end of harness (marked with blue tape) back towards the rear of the tractor and secure to the switch harness with wire tie.



**NOTE:** The free end of the harness should be oriented at the rear of the tractor free of the 3pt linkage in a suitable location to connect to the sprayer.

- Connect Extension Harness (5CS50915) to the pump and retain to harness retention bracket (A) near pump with a wire tie.
- Store free end of harness in harness retention bracket slot (B).

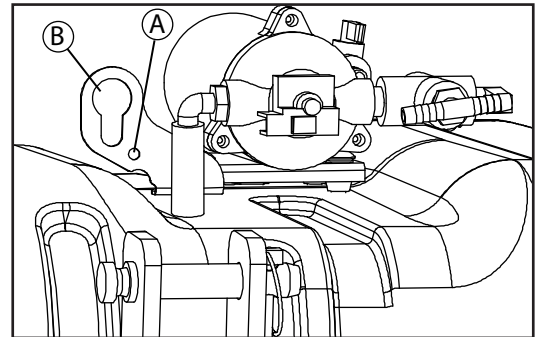

- Connect Battery Harness, black wire to negative terminal and red wire to positive terminal. Wires should exit the battery terminals towards the center of the battery.

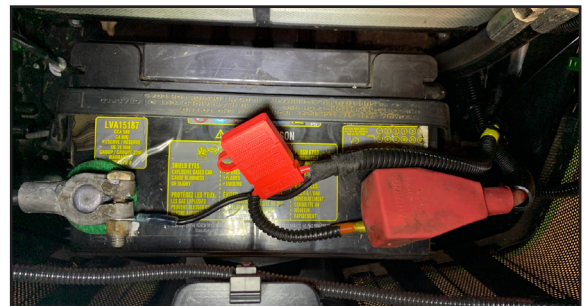

**NOTE:** Ensure positive battery terminal boot is covering the battery terminal and no exposed metal is visible.

### Preparation for installation on 2032R, 2038R

- Mark center of drill location 1-1/4" rearward from battery hold down bracket and 1" from leftward edge of battery recess on the left side of the tractor. If battery tray design differs from image shown, drill in the general vicinity that will accommodate the grommet's size.
- If required to fit drill, remove battery - follow your tractor operator manual instructions for

battery removal and installation.

3. Drill a 5/8" hole in the battery tray.
4. Remove any burrs and sharp edges.
5. Install grommet (5CS43985) in drilled hole.
6. Route the battery harness (5CS50912) through the grommet such that the two-way connector exists the battery compartment.

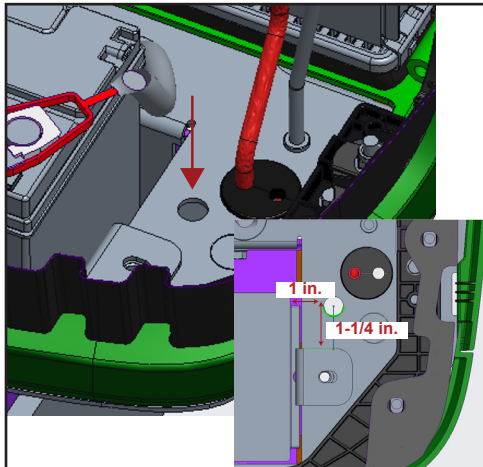

Harness" above.

*For 3D tractors:*

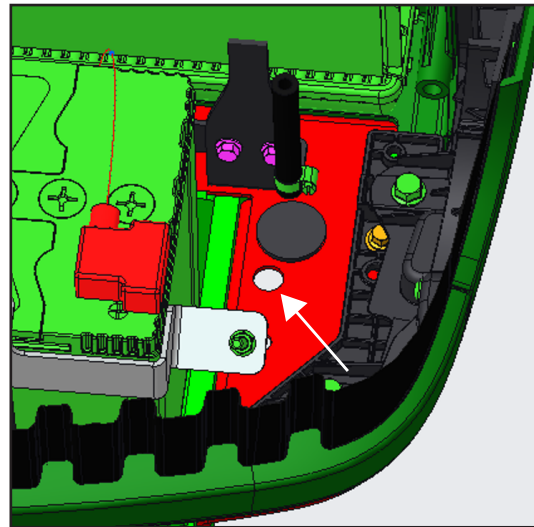

*For 3E tractors:*

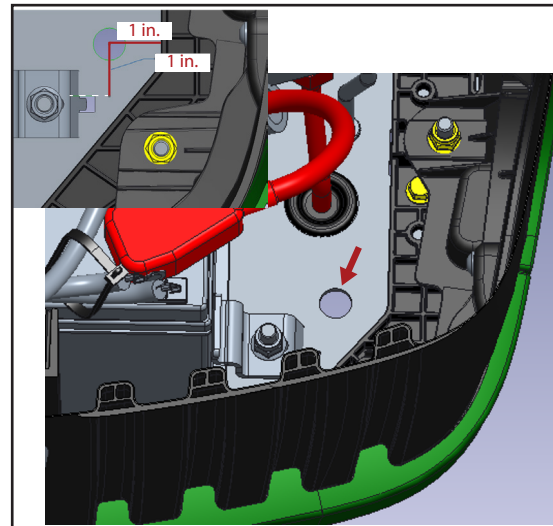

7. Continue with step 4 of "Install Wiring Harness" above.

### Special Installation Instructions for 3D & 3E tractors

1. If required to fit drill, remove battery - follow your tractor operator manual instructions for battery removal and installation.
2. (For 3D only) Remove existing plug on left side of battery tray (JD Part No. 99M7073).
3. (For 3E only) Mark center of drill location 1" rearward from battery hold down bracket tab cutout and 1" from rightward from edge of grille (JD Part Co. LVU30453) on the left side of the tractor. If battery tray design differs from image shown, drill in the general vicinity that will accommodate the grommet's size.
4. Drill a 5/8" hole in existing hole where plug was removed.
5. Remove any burrs and sharp edges.
6. Install grommet (5CS43985) in drilled hole.
7. Route harness through grommet with fuse holder inside the battery compartment.
8. Continue with step 4 of "Install Wiring

# INSTALLATION

## Sprayer Installation

### Installing Ballast



**CAUTION: Avoid Injury!** Machine can become unstable when operating with attachment. Ballast is required when the attachment is installed.

### Compact Utility Tractors

See Specification Section for implement code and refer to Ballasting Machine in your tractor operator's manual to determine the number of front weights required to ballast the tractor.

### Attaching the Sprayer to Tractor

1. Park machine safely. (See Park Machine Safely in Safety section)
2. Lower tractor lift link to lowest position.
3. Mount sprayer on 3-point hitch.
4. Remove harness from retention bracket and connect to the free end of switch harness.

### Attaching the Sprayer to Tractor with iMatch - Quick Hitch

1. Connect iMatch – Quick Hitch to tractor first following the iMatch – Quick Hitch installation instructions.
2. Install bushing set (sold separately), John Deere Part Number BW15056 or equivalent, to lower draft pins and top link pin on sprayer.
3. Lower the tractor's 3-pt hitch aligning the center hook of the iMatch – Quick Hitch just below the top link pin on the sprayer.
4. Ensure all three connection points are aligned.
5. Raise tractor's 3-pt hitch ensuring lower draft pins and top link are fully engaged with iMatch – Quick Hitch.

6. Close both levers on iMatch – Quick Hitch to lock lower draft pins in place. Levers are closed when they are folded down (horizontal position).

## Removing and Storing Sprayer

### Removing Sprayer from Tractor



**CAUTION: Avoid Injury!** When the attachment is removed, also remove any ballast that was added to the machine.

1. Park machine safely. (See Park Machine Safely in Safety section)
2. Empty the sprayer tank.
3. Lower the sprayer to the ground.
4. Disconnect wiring harness from switch harness, install connector cap and store harness by placing free end into harness retention bracket slot (A).

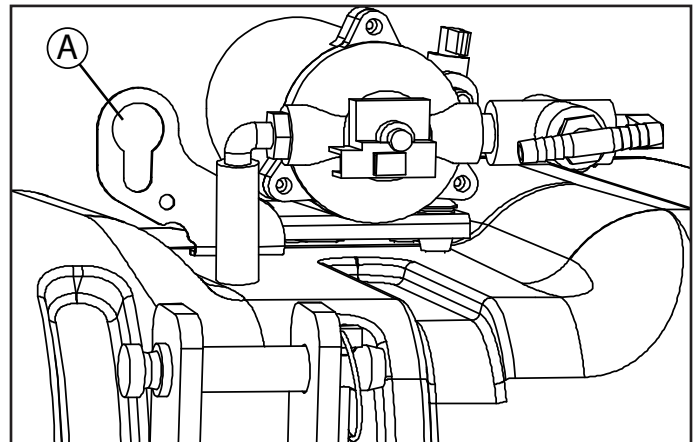

5. Disconnect sprayer from the 3-point hitch.
6. Remove any added ballast from Tractor.

## Store Sprayer Safely



### **CAUTION: Avoid Chemical Injury!**

- Wear protective clothes, gloves and goggles when handling sprayer.
  - Do not store sprayer with chemicals in tank.
  - If sprayer comes in contact with your body, immediately follow directions on chemical container pertaining to spray material.
1. Pump all spray material from tank. (See Dispose of Waste Properly in Safety section.)
  2. Rinse tank, pump, spray wand and all hoses thoroughly with fresh clean water.
  3. Repeat step 2 several times.
  4. Wipe out sump with a clean cloth or paper towel.
  5. Drain hoses and pump filter.
  6. Check sprayer for worn or damaged parts. Replace parts as needed.
  7. Tighten loose hardware.
  8. Store sprayer in a place where it will not freeze.

# OPERATION

## Sprayer Setup

### Filling Sprayer Tank



**CAUTION: Avoid injury to operator or bystanders!**

- Read chemical container label for mixing and handling instructions. A Safety Data Sheet (SDS) should be supplied by the chemical dealer and provides proper safety information.
- Wear proper clothing and safety equipment while handling or applying spray chemicals.
- Wear a full covering of clothing, protective goggles and rubber gloves.
- Prohibit all smoking, drinking, and eating around chemicals.
- When filling tank, never allow end of water hose to contact chemical mixture.

**IMPORTANT:** *Avoid damage! Clean any spills immediately with clean water prior to operating sprayer.*

1. Park machine safely. (See Park Machine Safely in Safety section)
2. Lower tractor lift link so that the sprayer is firmly on the ground
3. Clean area around tank filler cap to prevent tank contamination.
4. Remove tank filler cap and fill tank.
5. Install tank filler cap.

**NOTE:** *The preferred location to fill the tank is from the front left corner.*

### Draining and Cleaning the Sprayer Tank



**CAUTION:** *Avoid damage!*

- Clean any spills
- Proper disposal of excess spray material is very important.

- Never dump excess spray material into a storm drain or near a lake or stream.

1. The preferred method of cleaning is to dilute remaining material with water and apply it to the area previously treated.
  - If excess material remains, open drain valve and empty remaining material into an appropriate container for reuse or for disposal according to local regulations or as specified in the manufacturer's label.
2. Spray all inside surfaces of tank with low pressure garden hose to remove any remaining solution. Close drain valve and run clean water through the pump, hoses and boom applying those contaminated contents on previously treated area.
3. Rinse outside of sprayer tank thoroughly with fresh clean water. Rinse several times to make sure sprayer tank is clean and free of chemicals.
4. Once the tank is empty, wipe out inside of sprayer tank with a clean cloth or paper towel.
5. Close drain valve and filler cap.

### Calibrating the Sprayer

When spraying with boom, sprayer must be calibrated to ensure proper spray coverage and to combat over-application or under-application. The calibration process consists of three steps:

1. Calculate speed of tractor.
2. Determine nozzle size and consult calibration chart for desired or instructed gallon per acre (GPA).
3. Set pressure using relief valve.

### Calculating the Speed

It is important to determine what speed the tractor will be traveling while spraying. Even if tractor has a speedometer, it is still recommended that speed be checked for accuracy. Perform the following steps to

determine speed:

1. Measure a 200 or 300 foot distance on a field or surface similar to where sprayer will be used.
2. Drive tractor with half-full sprayer across measured distance at a constant and comfortable speed for spraying. There can be no changes in speed while measuring time.
3. Determine amount of time, in seconds, it takes to travel the measured distance.
4. Speed can be determined by entering data into the following equation: speed (mph) = (distance (ft) x 60) / (time (sec) x 88) or by consulting the following table

Speed in MPH	Time (sec) required to travel a distance of:	
	200 ft	300 ft
1.0	136	205
1.5	91	136
2.0	68	102
2.5	55	82
3.0	45	68
3.5	39	56
4.0	34	51
4.5	30	45
5.0	27	41
5.5	25	37
6.0	23	34
6.5	21	31
7.0	19	29

*NOTE: If using boomless nozzles, use the Boomless Nozzle Calibration Chart.*

### Useful Formulas

GPA = Gallons per Acre

GPM = Gallons per Minute

MPH = Miles per Hour

GAL/1000 sq ft = Gallons per 1000 sq ft

W = Nozzle spacing in inches

GPM Per Nozzle = GPA x MPH x W / 5940

GPM Per Nozzle = GAL/1000 sq ft x MPH x W / 136

GPA = 5940 x GPM (Per Nozzle) / MPH x W

GPA = Gallons per 1000 sq ft / 0.023

GAL/1000 sq ft = 136 x GPM (Per Nozzle) / MPH x W

*NOTE: Replace worn tips that have a streaky or uneven pattern.*

GPM	Seconds to collect 1 qt	GPM	Seconds to collect 1 qt
0.05	300	0.20	75
0.06	250	0.23	67
0.07	214	0.25	60
0.08	188	0.30	50
0.09	167	0.35	40
0.10	150	0.40	35
0.11	136	0.50	30
0.12	125	0.60	25
0.13	115	0.70	20
0.14	107	0.80	18
0.15	100	0.90	17
0.17	80	1.00	15

### Determining Nozzle Size and Using Calibration Chart

STANDARD / PRECISION BOOM						
Tip Size	PSI	GPM one nozzle	GPA			
			2 MPH	3 MPH	4 MPH	5 MPH
TF-VP3	10	0.3	29.7	19.8	14.9	11.9
	20	0.4	41.6	27.7	20.8	16.6
	30	0.5	51.5	34.3	25.7	20.6
	40	0.6	59.4	39.6	29.7	23.8

The spray nozzles on your sprayer are TF-VP3, which match up with the calibration chart. Refer to the calibration chart. Using tractor speed, nozzle size, and desired gallons per acre (GPA), find pressure (psi) necessary to achieve your GPA.



*NOTE: Lower pressure settings will result in less spray drift.*

Example:

Assume tractor speed is determined to be 4 mph, nozzles are gray (TFVP3), and desired GPA is 20 GPA. The calibration charts shows that you should set sprayer's pressure at about 20 psi in order to apply 20 GPA.

*NOTE: Optimum spray performance is achieved between 20-25 psi. When shutting off outer tips, use the regulator valve to adjust your boom pressure accordingly.*

### Boomless Calibration

Right and Left Nozzles: 1/4XP10R

Center Nozzle: TF-VP3

Drop Size: XC

BOOMLESS CALIBRATION CHART FOR 24" HEIGHT						
PSI	Cap. 3 Nozzle GPM	Spray Width "ft"	GPA			
			4 MPH	6 MPH	8 MPH	10 MPH
20	1.8	23	10.5	7.1	5.1	4.2
30	2.3	25	11.2	6.5	5.6	4.5
40	2.6	28	11.9	7.9	6.0	4.8

BOOMLESS CALIBRATION CHART FOR 36" HEIGHT						
PSI	Cap. 3 Nozzle GPM	Spray Width "ft"	GPA			
			4 MPH	6 MPH	8 MPH	10 MPH
20	1.8	25	10.1	6.6	5.0	3.8
30	2.3	28	10.4	6.9	5.2	4.1
40	2.6	30	10.7	7.2	5.4	4.3

### Adjusting the Sprayer Pressure

*NOTE: All calibration needs to be done with clean water.*

Once correct pressure setting has been determined, the sprayer must be adjusted to that pressure setting. Before adjusting sprayer's

pressure, it is important to set tractor rpm at rate that was used to determine tractor speed.

### 2.2 gpm pump

Although the pressure can be adjusted by partially opening the control valve (A), it is recommended that the valve be placed in the full open position.

- The 10 ft boom is equipped with the TF-VP3 tips and sprays at approximately 20 PSI through the boom when the valve is in open position.
- For calibration purposes, adjust your speed for proper coverage.

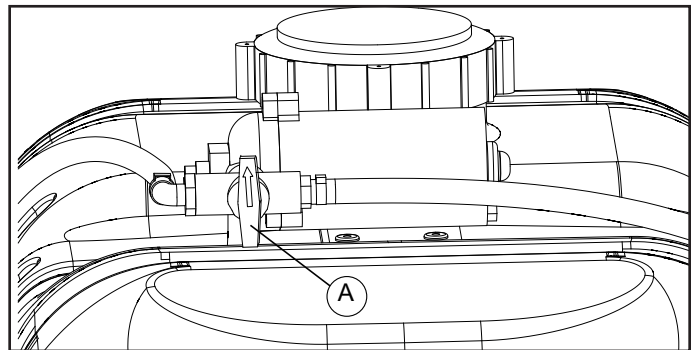

### 4.0 gpm pump

1. Loosen lock ring (B) and adjust knob (C) to desired pressure. Pressure is displayed on gauge (D).
2. Once desired pressure is achieved tighten lock ring (B).
3. Sprayer is now calibrated.

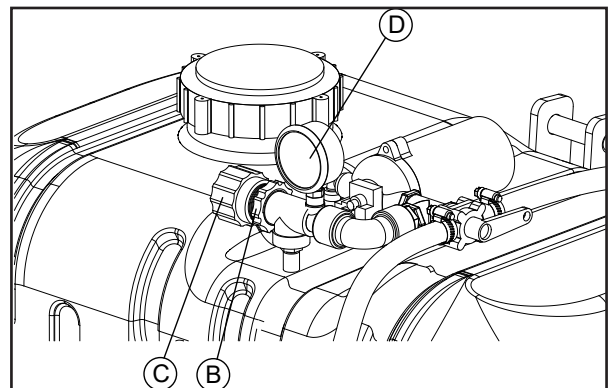

## Operating the Sprayer with 2.2 gpm pump

### Starting and Stopping the Sprayer

1. Turn the selector lever (A) on the sprayer to the desired position, spray wand/nozzle or spray boom.
  - The arrow on the handle of the valve indicates the direction material will flow.
2. Turn the in-line switch on the switch harness to the ON Position.
3. To stop flow to the spray nozzles, turn the lever to the OFF position.
4. Turn the in-line switch on the switch harness to the OFF Position.

### Boom Section Control

The Boom is divided into 3 sections of spray tips. Right, Center and Left. The Left and Right sections (end nozzles) can be turned on and off by turning the corresponding in-line valve on the boom.

### 10 ft Boom

- 60 inches - Both Left and Right sections OFF.
- 90 inches - Either Left or Right section OFF.
- 120 inches - Both Left and Right sections ON.

### Using the Spray Wand



**CAUTION: Avoid Injury!** DO NOT use spray wand while tractor is in motion.

1. Turn the selector lever to the handgun position.
2. Adjust nozzle:
  - Nozzle Angle – Loosen locknut (B). Turn the nozzle tube (C) to the desired position and tighten the locknut.
  - Nozzle Spray Pattern – To change the spray pattern, tighten or loosen nozzle (D) as desired.

3. Squeeze the handle (E) to spray.
4. Push lock (F) forward to lock handle in ON position.

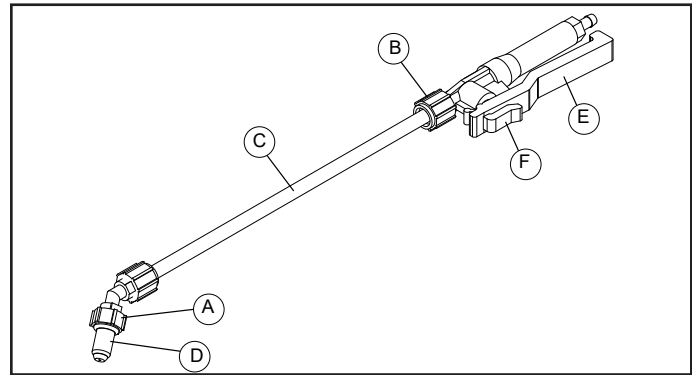

## Operating the Sprayer with 4.0 gpm pump

*NOTE: Ensure pressure is set to desired pressure from calibration process. If not, follow steps 1-3.*

1. Loosen lock ring (B) and adjust knob (C) to desired pressure. Pressure is displayed on gauge (D).
2. Once desired pressure is achieved. Tighten lock ring (B).
3. Turn Selector lever (E) to desired position, spray wand/nozzle or spray boom.

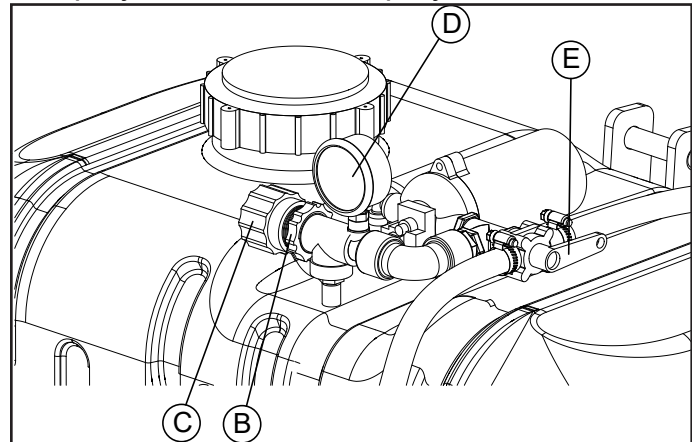

### Boom Section Control 12.5 ft and Boomless

The Boom is divided into 3 sections of spray tips. Right, Center and Left. The Left and Right sections can be turned on and off by turning the corresponding in-line valve on the boom.

## 12.5 ft Boom Spray Width

- 30 inches - Both Left and Right sections OFF.
- 90 inches - Either Left or Right section OFF.
- 150 inches - Both Left and Right sections ON.

## Boomless Spray Width

- 2.5 ft - Both Left and Right sections OFF.
- 12 ft - Either Left or Right section OFF.
- 24 ft - Both Left and Right sections ON.

## Using the Spray Nozzle



**CAUTION: Avoid Injury!** DO NOT use spray gun while tractor is in motion.

1. Turn the selector lever to the handgun position.
2. Squeeze the handle (A) to spray.
3. Adjust mist to stream using lever (B).
4. Spray guard (C) can be adjusted by loosening (D) and sliding spray guard to desired position. The spray guard is intended to keep over-spray off your hands.
5. Flip handle lock (E) forward to lock handle in ON position.

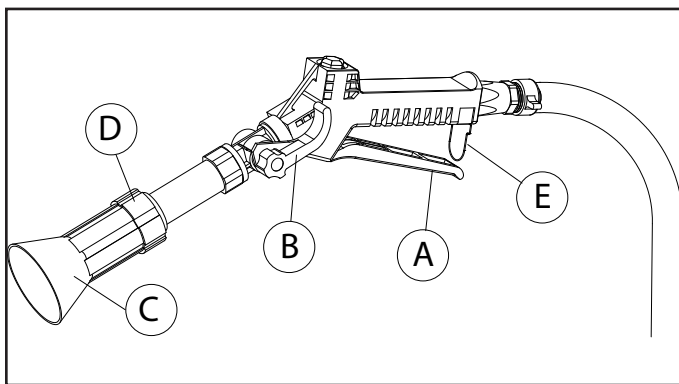

# SERVICE

## Servicing Sprayer Safely



**CAUTION: Avoid injury to operator or bystanders!**

- Wear protective clothes, gloves and goggles when handling sprayer.
- Do not put the nozzle tips or other parts to your lips to blow out dirt.
- If spray comes in contact with your body, immediately follow directions on chemical container pertaining to spray material.

## Servicing the Pump

Follow all pump safety precautions and warnings. Following these guidelines will help to ensure many years of smooth and trouble-free sprayer operation.

- Flush pump out with fresh water after every use.
- Winterize pump to prevent freezing and corrosion.
- Refer to Winterizing Sprayer for instructions.

## Winterizing Sprayer

It is important to winterize sprayer to avoid damage from freezing and corrosion before temperatures reach freezing levels.



**CAUTION: Avoid injury!** Do not use standard antifreeze. Standard antifreeze can be harmful to humans, animals, crops and the environment.

1. Empty and rinse tank.
2. Put one to two gallons of RV nontoxic antifreeze in tank.
3. Engage pump and spray with boom and subsequently spray gun (if applicable). Ensure that antifreeze has been pumped through entire system, including all spray nozzles.

4. Store sprayer in a dry location away from elements.

## Placing Sprayer Back in Service after Winterizing

1. Flush sprayer with fresh water to clean out all antifreeze and any other buildup.
2. Do a thorough inspection of all components before spraying.

## Cleaning Spray Tips



**CAUTION: Avoid injury!**

- Wear protective clothes, gloves and goggles when handling sprayer.
  - Do not put the nozzle tips or other parts to your lips to blow out dirt.
  - If spray comes in contact with your body, immediately follow directions on chemical container pertaining to spray material.
1. Remove spray nozzle (A) from sprayer.
  2. Remove the spray tip (B) and gasket (C) from the spray nozzle (A).
  3. Remove the screen (D) from the nozzle socket on the boom. Replace the screen if damaged.



**IMPORTANT: Avoid damage!** Do not use a wire to clean the opening (E) in the spray tip.

4. Wash the screen (D) and spray tip (B) in a nonflammable solvent.
5. Align the flat side (F) of the spray tip with the flat on the opening of the spray nozzle (A), and install the spray tip into the nozzle.

*NOTE: Verify that the opening (E) in the spray tip is pointing down when the nozzle assembly is installed on the nozzle socket.*

6. Install the screen (D) into the nozzle socket on the boom.
7. Install nozzle assembly on the nozzle socket.

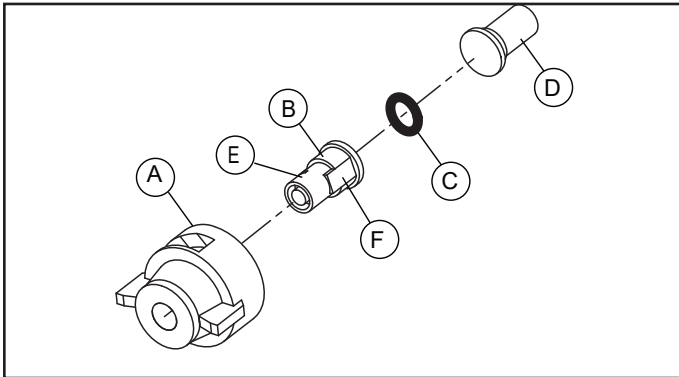

### Cleaning Pump Suction Screen

1. Remove tank cover.
2. Locate suction screen (A) inside sprayer tank.
3. If necessary, unscrew suction screen, and clean with liquid detergent and warm water.
4. If suction screen was removed, install on suction hose and position in lowest depression inside tank.
5. Install and tighten tank cover.

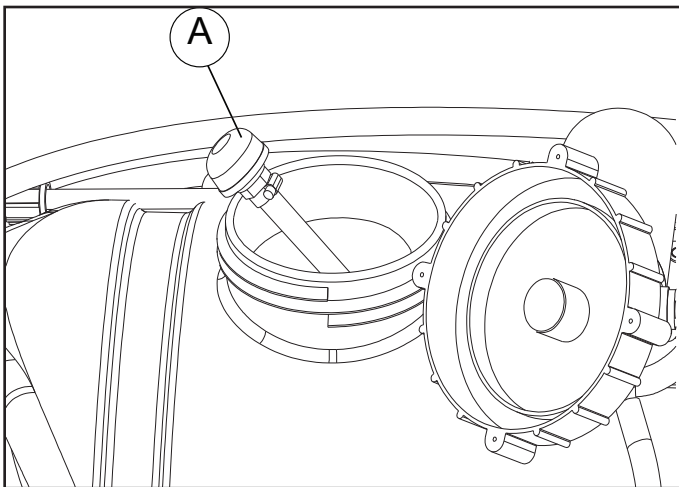

### Cleaning the Spray Wand Nozzle

1. Unscrew nozzle (A) from the spray tip (B).
2. Loosen nut (C), and remove the spray tip (B) from the angled fitting (D).
3. Loosen the locknut (E), and remove the angled fitting (D) from the handgun (F).

4. Wash nozzle (A), spray tip (C) and angled fitting (D) with liquid detergent and warm water.
5. Inspect O-rings (G and H). Replace as needed.
6. Install angled fitting (D) on handgun (F), and tighten locknut (E).
7. Slide nut (B) over the spray tip (C), and install on angled fitting (D).
8. Install nozzle (A) on spray tip (C).

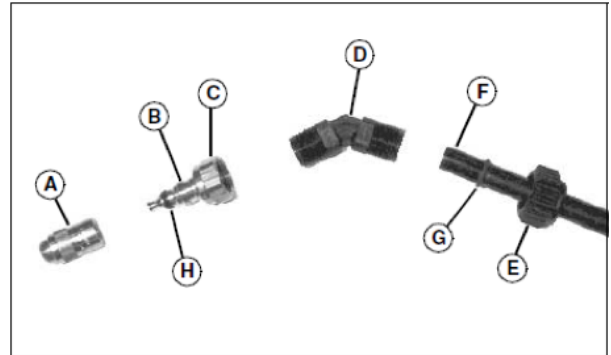

## Quality Service

### Frontier Quality Continues with Quality Service

Frontier provides a process to handle your questions or problems, should they arise, to ensure that product quality continues with your Frontier dealer's parts and service support.

Follow the steps below to get answers to any questions you may have about your product.

1. Refer to the appropriate attachment, machine or equipment operator's manuals.
2. Contact your Frontier dealer with unanswered questions.

# TROUBLESHOOTING

## Troubleshooting Sprayer

### Using the Troubleshooting Chart

If you are experiencing a problem that is not listed in this chart, see your authorized dealer for service.

When you have checked all the possible causes listed and you are still experiencing the problem, see your authorized dealer.

### Troubleshooting Chart

IF	CHECK
Pump Loses Suction	Clean pump suction screen. Check tank fill level. Fill tank. Clean or replace pump. Check for loose pump fittings.
Pump Capacity Decreased	Clean pump suction screen. Clean spray nozzle(s). Selection lever is not completely turned on, or is on the OFF position.
Poor Spray Pattern	Clean spray nozzles. Adjust nozzle height. Align spray tips with boom.
Pump Does Not work	Check wiring connections. Check machine battery. Clean debris from pump. Check pump switch. Check pump motor.

# SPECIFICATIONS

		Boom Option		
		10 ft	12.5 ft	Boomless
<b>Capacity</b>	Sprayer Tank	45 gal (170 L)		
<b>Dimension</b>	Working Width	10 ft (3 m)	12.5 ft (3.8 m)	24 ft (7.3 m)
	Transport Width	44 in (112 cm)	52 in (132 cm)	33 in (84 cm)
	Transport Length	32 in (81 cm)	32 in (81 cm)	28 in (71 cm)
	Transport Height	32 in (81 cm)	34 in (86 cm)	34 in (86 cm)
<b>Weight</b>	Empty Weight	79 - 96 Lbs (36 - 44 Kg)		
	Laden Weight	496 - 513 Lbs (225 - 233 Kg)		
<b>Tractor Requirement</b>	Hitch Compatibility	Limited CAT 1 / CAT 1		
	Quick Hitch Compatibility	Yes		
	Voltage	12 VDC		
	Current Draw Pump A	10.0 A @ 100 psi	-	-
	Current Draw Pump B	-	17.5 A @ 100 psi	
<b>Pump</b>	<b>Pump A</b>	Electric Diaphragm		
	Max Flow	2.2 gpm (8.3 l/min)	-	-
	Max Pressure	100 psi (6.9 bar)	-	-
	<b>Pump B</b>		Electric Diaphragm	
	Max Flow	-	4.1 gpm (15.5 l/min)	
	Max Pressure	-	100 psi (6.9 bar)	
<b>Boom</b>	Type	Dry boom		N/A
	Hose Size	3/8 in (.95 cm)	1/2 in (1.3 cm)	1/2 in (1.3 cm)
	Construction	Square tube		N/A
	Breakaway	Rear		N/A
	Fold	Manual		N/A
	Sections	3	3	3
<b>Application System</b>	<b>Spray Tips</b>			
	Qty	4	5	3
	Type	Air Induction, 110° Flat Spray		Flood
	Size	0.4 gpm (1.5 l/min)	0.4 gpm (1.5 l/min)	0.5 gpm (1.9 l/min)
	Spacing	30 in (76 cm)	30 in (76 cm)	N/A
	Nozzle Body	1/4 turn diaphragm with check valve		
	<b>Control System</b>			
	Pump Control	inline switch		
	Pressure Control	N/A	Adjustable	Adjustable
	Max Working Pressure	100 psi (6.9 bar)	100 psi (6.9 bar)	100 psi (6.9 bar)
	Section Control	Inline Valves		
	Agitation	excess flow plumb to tank		
	<b>Spot Sprayer</b>			
	Style	Spray Wand	Spray Gun	Spray Gun
	Hose Length	20 ft (6.1 m)		

# TRACTOR BALLASTING

Boom Options			Full Tank	
24 ft Boomless	10ft Boom	12.5ft Boom	Weight (lbs)	Implement Code
		X	513	26
	X		507	26
X			496	25



# PARTS DIAGRAMS

## Safety Decals Kit and Model Decals

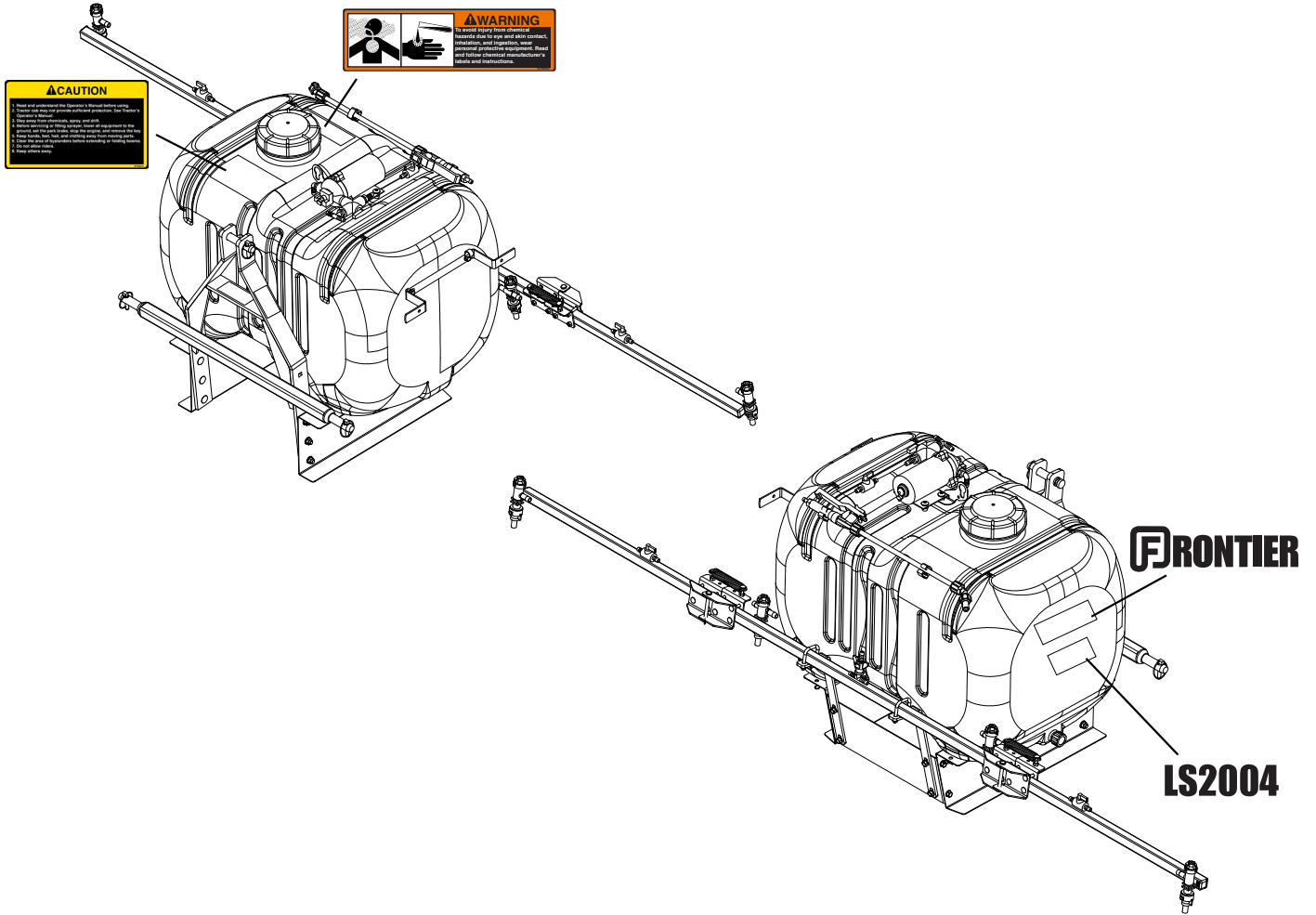

- 1 - English
- 2 - French
- 3 - Spanish

- 4 - English
- 5 - French
- 6 - Spanish

OPERATOR'S MANUAL

**LIQUID SPRAYER**

LS2004

**FRONTIER**

Operator's Manual and Safety Decal Kit

LS2004

Replacement Decal Kit

## Safety Decals Kit and Model Decals

ITEM NO.	PART NUMBER	DESCRIPTION	QTY.	Note
1	5CS0024	OM and Safety Decal Kit - English	1	Includes Operator's Manual, Caution Label and Warning Label
2	5CS0027	OM and Safety Decal Kit - French	1	
3	5CS0030	OM and Safety Decal Kit - Spanish	1	
4	5CS43997	Replacement Decal Kit - English	1	Includes Caution Label, Warning Label, Frontier Decal and Model Decal
5	5CS43998	Replacement Decal Kit - French	1	
6	5CS43999	Replacement Decal Kit - Spanish	1	

# Frame and Tank

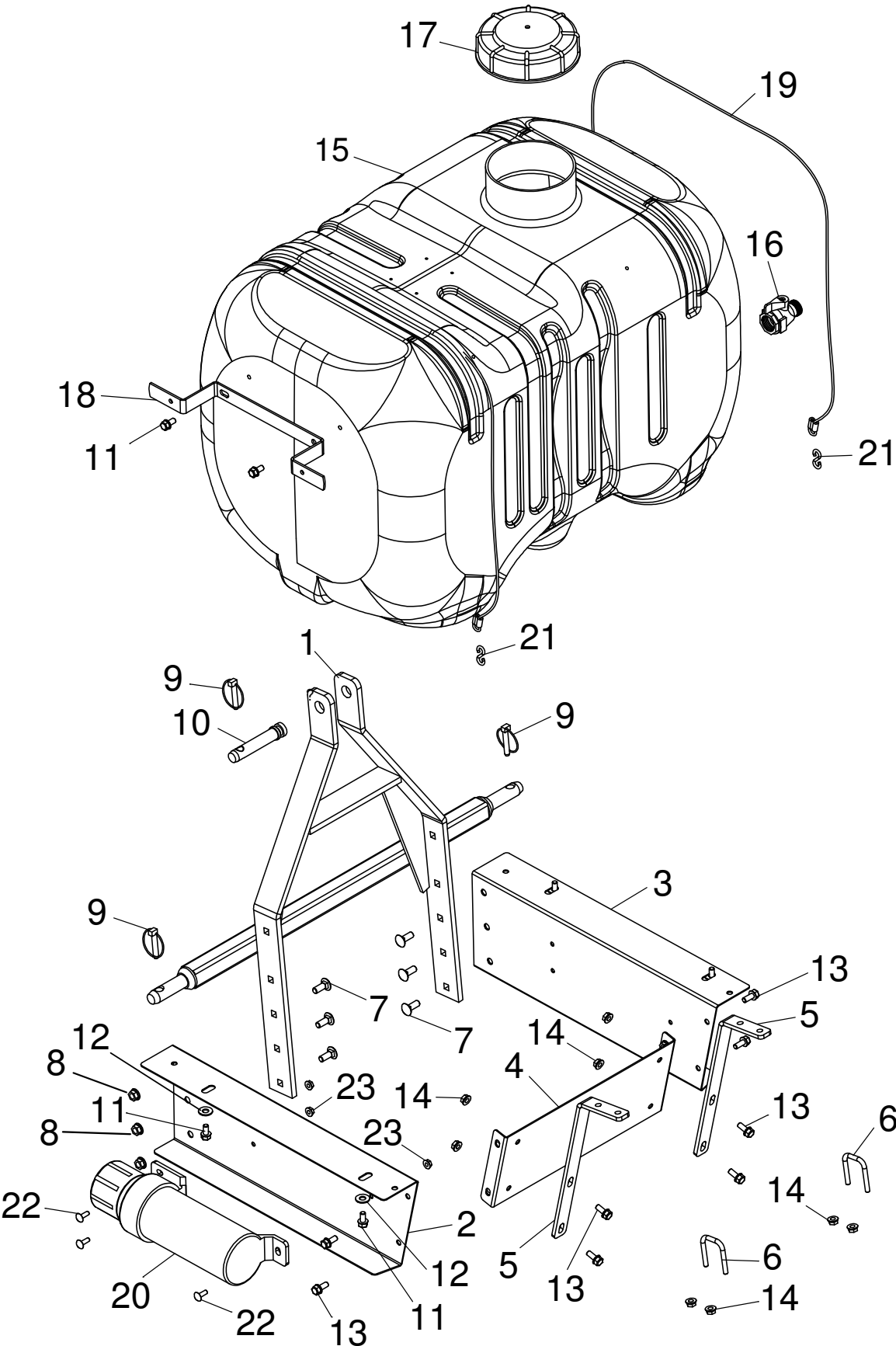

## Frame and Tank

ITEM NO.	PART NUMBER	DESCRIPTION	QTY.	Note
1	5CS61500	3 Point A Frame	1	
2	5CS61502	Frame Base Left	1	
3	5CS61503	Frame Base Right	1	
4	5CS61504	Frame Base Rear	1	
5	5CS61505	Boom Support	2	
6	5CS43315	5/16" x 1-3/4" Square U-Bolt	2	
7	03H1500	3/8" x 1" Carriage Bolt	6	
8	E55662	3/8" Flange Nut	6	
9	5CS43398	Lynch Pin	3	
10	5CS43399	Top Link Pin, Cat 1	1	
11	T58694	5/16" x 5/8" Flange Bolt	6	
12	T406296	3/8" Flat Washer	4	
13	5CS65007	5/16" x 3/4" Flange Bolt	8	
14	A22698	5/16" Flange Nut	12	
15	5CS43530	Tank 45 Gallon	1	
16	5CS43981	Garden Hose Shut-off Valve	1	
17	5CS43175	Tank Lid 6"	1	
18	5CS62006	Hose Hanger	1	
19	5CS61511	Cable Lanyard w/ I-hook	2	
20	5CS43950	Manual Canister	1	
21	5CS61512	S-hook	2	
22	03H1701	1/4" x 3/4" Carriage Bolt	3	
23	N10217	1/4" Flange Nut	3	
-	5CS50912	Battery Harness	1	Not Illustrated
-	5CS50913	Chasis Harness	1	Not Illustrated
-	5CS50914	Switch Harness	1	Not Illustrated
-	5CS50915	Sprayer Extension Harness	1	Not Illustrated
-	5CS48616	Fir Tree w/ wire tie	1	Not Illustrated
-	5CS43984	Edge Clip w/ wire tie	1	Not Illustrated
-	5CS43985	Grommet 24.75 mm	1	Not Illustrated
-	5CS43986	Wire Tie, Black Nylon UV, 10"	10	Not Illustrated

## 2.2 GPM Pump and Hand Sprayer

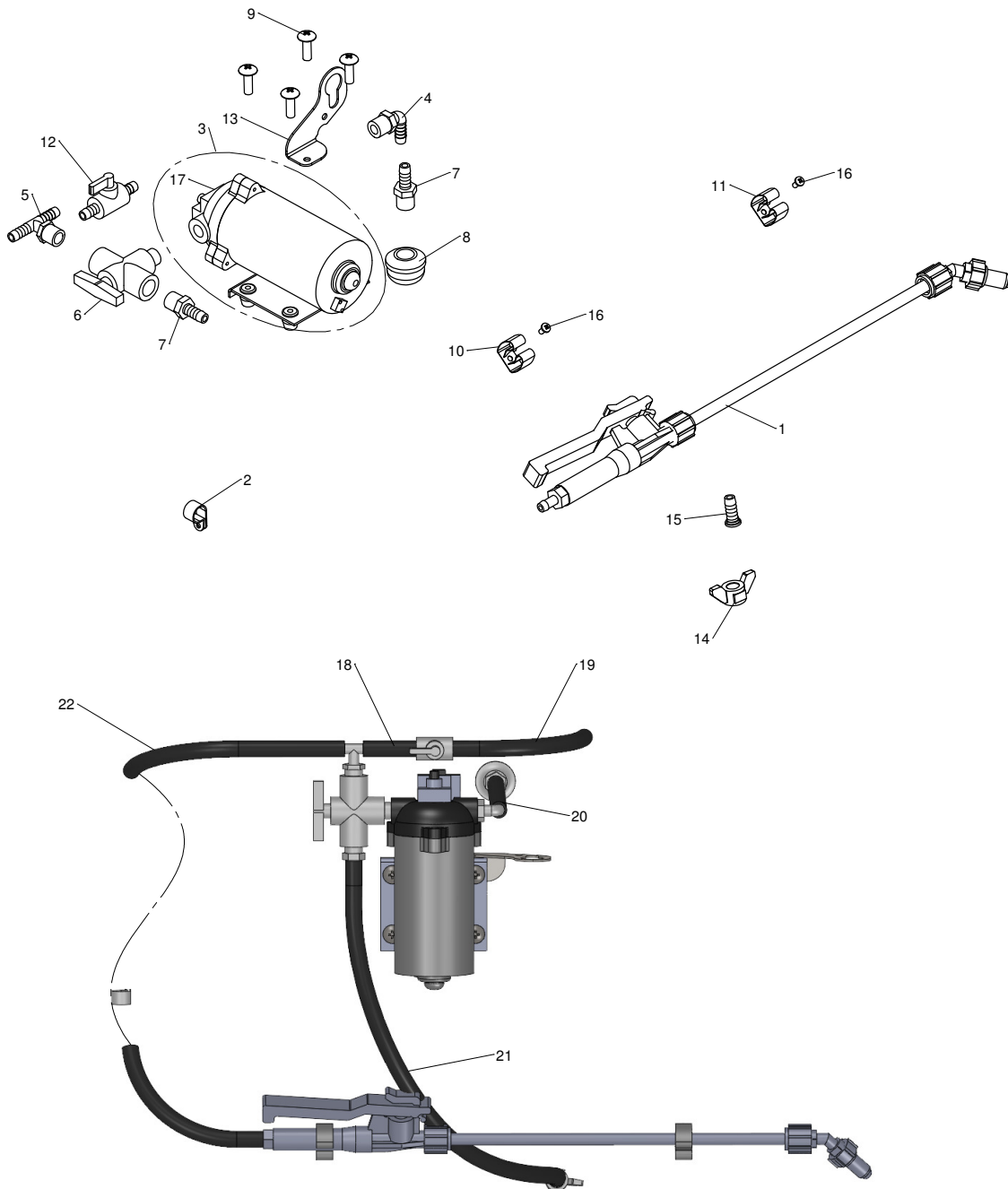

ITEM NO.	PART NUMBER	DESCRIPTION	QTY.	Note
1	5CS43673	Spray Wand w/ Brass Tip	1	
2	5CS43674	Hose Holder 3/8"	1	
3	5CS43918	Pump 2.2 GPM 100 PSI	1	
4	5CS43183	Elbow 3/8" NPT - 3/8" Barb	1	
5	5CS43235	Tee 3/8" NPT -3/8" Barb	1	

## 2.2 GPM Pump and Hand Sprayer

ITEM NO.	PART NUMBER	DESCRIPTION	QTY.	Note
6	5CS43181	Selector Valve 3/8"	1	
7	5CS43182	Fitting Straight 3/8" Barb	2	
8	5CS43258	Sump Strainer 3/8"	1	
9	5CS65001	#10-24 x 1" Truss Head Screw	4	
10	5CS43287	Spray Wand Clip Large	1	
11	5CS43130	Spray Wand Clip Small	1	
12	5CS43014	In-line Valve 3/8"	1	
13	5CS43973	Harness Retention Bracket	1	
14	5CS43498	Plastic Wing Nut	1	
15	5CS43499	3/8" Barb Fitting for Wing Nut	1	
16	5CS65000	#10-24 x 3/8" Truss Head Screw	2	
17	5CS43921	2.2 GPM Pump Head Replacement	1	
18		3/8" Hose	1	CTL 2.5", MF 5CS43286
19		3/8" Hose	1	CTL 8", MF 5CS43286
20		3/8" Hose	1	CTL 22", MF 5CS43286
21		3/8" Hose	1	CTL 28", MF 5CS43286
22		3/8" Hose	1	CTL 240", MF 5CS43286
-	5CS43652	Hose Clamp Screw Type 3/8" - 1/2"	8	Not Illustrated
-	5CS43844	Grommet 5/8" ID	2	Not Illustrated

# 4.0 GPM Pump and Hand Sprayer

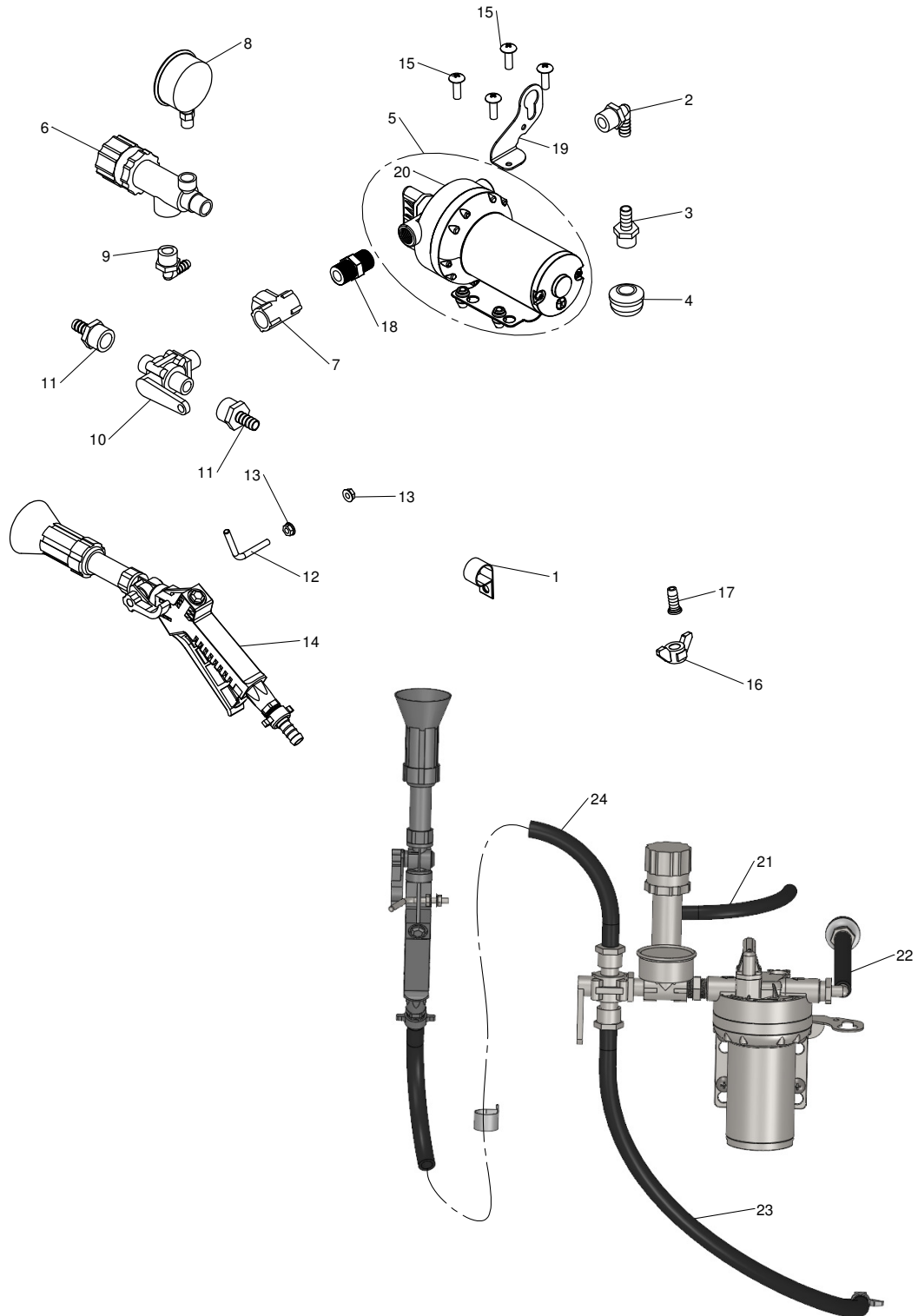

## 4.0 GPM Pump and Hand Sprayer

ITEM NO.	PART NUMBER	DESCRIPTION	QTY.	Note
1	5CS43663	Hose Holder 1/2"	1	
2	5CS43803	Elbow 1/2" Barb - 1/2" NPT	1	
3	5CS43423	Fitting 1/2" Barb - 1/2" MP	1	
4	5CS43422	Sump Strainer 1/2"	1	
5	5CS43791	Pump 4.0 GPM 100 PSI	1	
6	5CS43591	Relief Valve 1/2"	1	
7	5CS43424	Tee 1/2" NPT	1	
8	5CS43593	Pressure Gauge	1	
9	5CS43590	Elbow 3/8" Barb - 1/2" NPT M	1	
10	5CS43430	Selector Valve	1	
11	5CS43587	Fitting 1/2" Barb - 1/2" NPT F	2	
12	5CS62008	1/4" Bent Pin	1	
13	N10217	1/4" Flange Nut	2	
14	5CS43435	Sprayer Handgun	1	
15	5CS65001	#10-24 x 1" Truss Head Screw	4	
16	5CS43498	Plastic Wing Nut	1	
17	5CS43426	Fitting Straight 1/2" Barb	1	
18	5CS43802	Pipe Nipple 1/2" NPT - 1/2" NPT	1	
19	5CS43973	Harness Retention Bracket	1	
20	5CS43889	4.0 GPM Pump Head Replacement	1	
21		3/8" Hose	1	CTL 12", MF 5CS43286
22		1/2" Hose	1	CTL 22", MF 5CS43418
23		1/2" Hose	1	CTL 28", MF 5CS43418
24		1/2" Hose	1	CTL 240", MF 5CS43418
-	5CS43652	Hose Clamp Screw Type 3/8" - 1/2"	5	Not Illustrated
-	5CS43844	Grommet 5/8" ID	1	For Item No. 21, Not Illustrated
-	5CS43854	Grommet 3/4" ID	1	For Item No. 22, Not Illustrated



# 10' Folding Boom

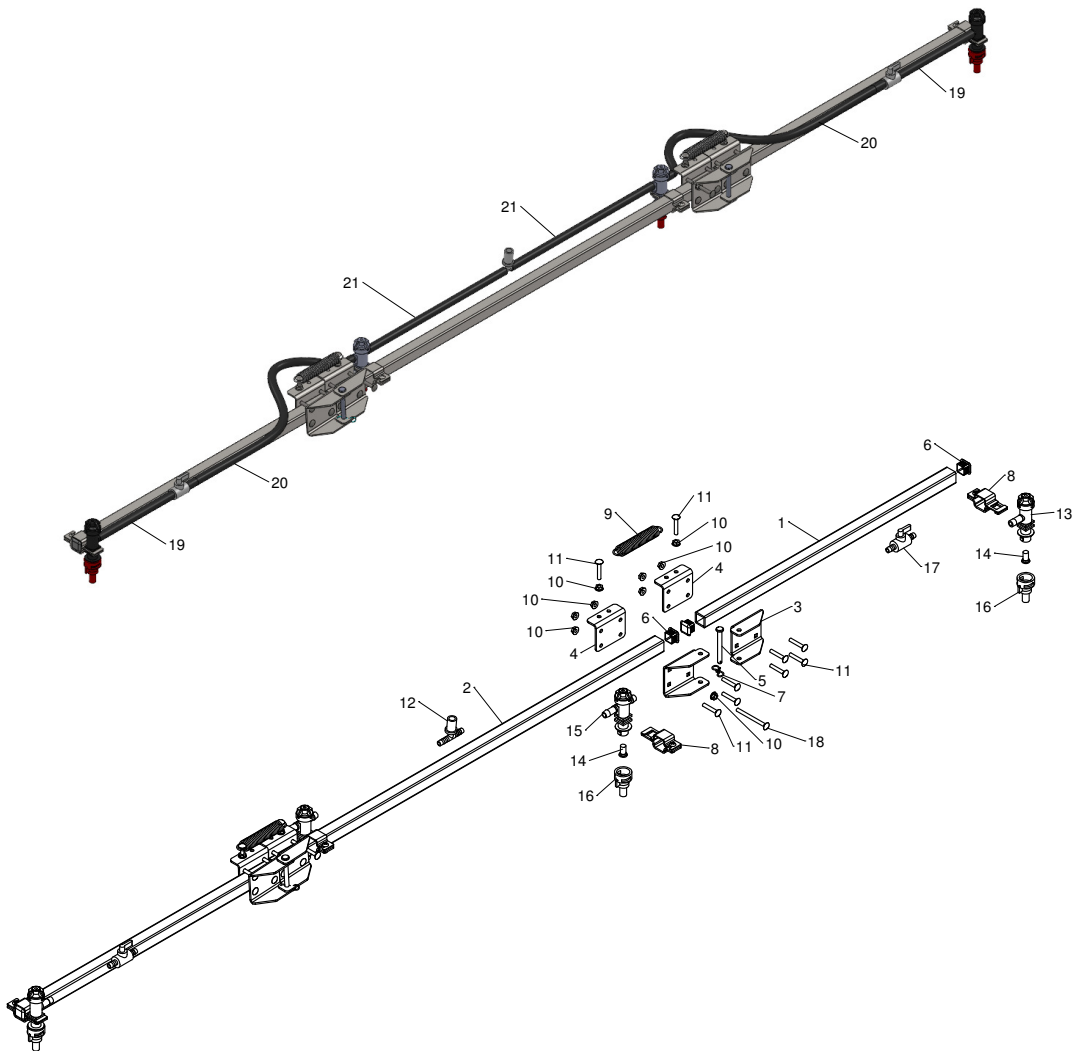

ITEM NO.	PART NUMBER	DESCRIPTION	QTY.	Note
1	5CS60084	Side Boom Tube 26"	2	
2	5CS60082	Center Boom Tube 40"	1	
3	5CS43849	Boom Hinge Bracket	4	
4	5CS43389	Boom Hinge Backing Plate	4	
5	5CS43402	5/16" x 3" Clevin Pin	2	
6	5CS43401	Plastic End Cap 1"	6	
7	5CS43624	Small Bowtie Clip	2	
8	5CS43598	Square Tube Clamp 1"	4	
9	5CS43403	Spring 3/4" x 3-3/4" x .105	2	
10	N10217	1/4" Flange Nut	26	

## 10' Folding Boom

ITEM NO.	PART NUMBER	DESCRIPTION	QTY.	Note
11	03H1810	1/4" x 1-1/2" Carriage Bolt	18	
12	5CS43192	Tee 3/8 Barb w/ Nut	1	
13	5CS43406	Nozzle Body Single Hose 3/8"	2	
14	5CS43411	Spray Tip Screen	4	
15	5CS43405	Nozzle Body Dual Hose 3/8"	2	
16	5CS43843	Air Induction Spray Tip 0.4 gpm	4	
17	5CS43014	In-line Valve 3/8"	2	
18	FH325451	1/4" x 3" Carriage Bolt	2	
19		3/8" Hose	2	CTL 4", MF 5CS43286
20		3/8" Hose	2	CTL 14.5", MF 5CS43286
21		3/8" Hose	2	CTL 29", MF 5CS43286
-	5CS43652	Hose Clamp Screw Type 3/8" - 1/2"	12	Not Illustrated

# 12.5' Folding Boom

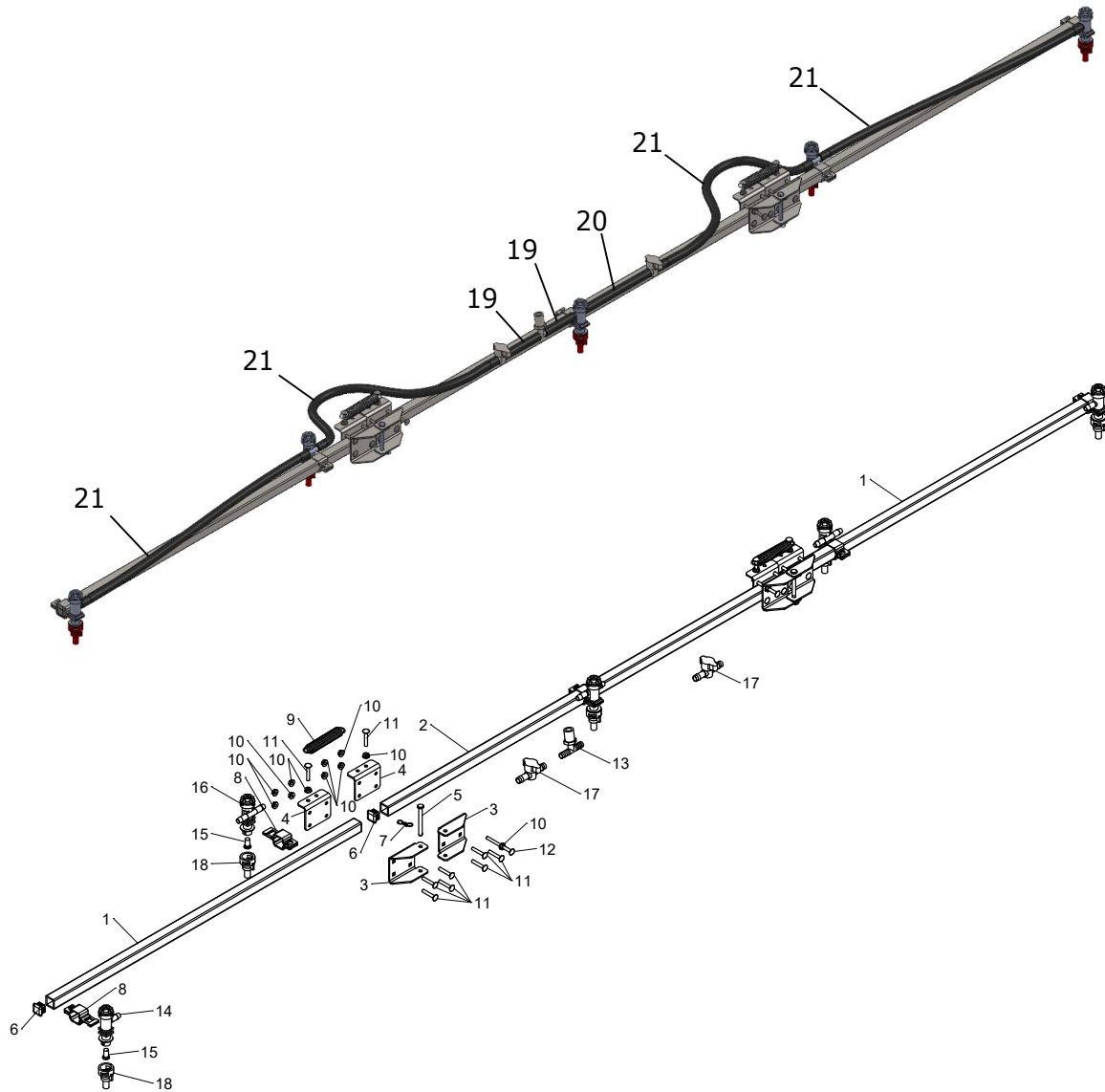

ITEM NO.	PART NUMBER	DESCRIPTION	QTY.	Note
1	5CS60085	Side Boom Tube 37"	2	
2	5CS60083	Center Boom Tube 48"	1	
3	5CS43849	Boom Hinge Bracket	4	
4	5CS43389	Boom Hinge Backing Plate	4	
5	5CS43402	5/16" x 3" Clevin Pin	2	
6	5CS43401	Plastic End Cap 1"	6	
7	5CS43624	Small Bowtie Clip	2	
8	5CS43598	Square Tube Clamp 1"	5	

## 12.5' Folding Boom

ITEM NO.	PART NUMBER	DESCRIPTION	QTY.	Note
9	5CS43403	Spring 3/4" x 3-3/4" x .105	2	
10	N10217	1/4" Flange Nut	26	
11	03H1810	1/4" x 1-1/2" Carriage Bolt	18	
12	FH325451	1/4" x 3" Carriage Bolt	2	
13	5CS43597	Tee 1/2" Barb - 1/2" NPT F	1	
14	5CS43658	Nozzle Body Single Hose 1/2"	2	
15	5CS43411	Spray Tip Screen	5	
16	5CS43595	Nozzle Body Dual Hose 1/2"	3	
17	5CS43736	In-line Valve 1/2"	2	
18	5CS43843	Air Induction Spray Tip 0.4 gpm	5	
19		1/2" Hose	2	CTL 2.5", MF 5CS43418
20		1/2" Hose	1	CTL 6", MF 5CS43418
21		1/2" Hose	4	CTL 19.25", MF 5CS43418
-	5CS43652	Hose Clamp Screw Type 3/8" - 1/2"	14	Not Illustrated

# Boomless 24' Spray

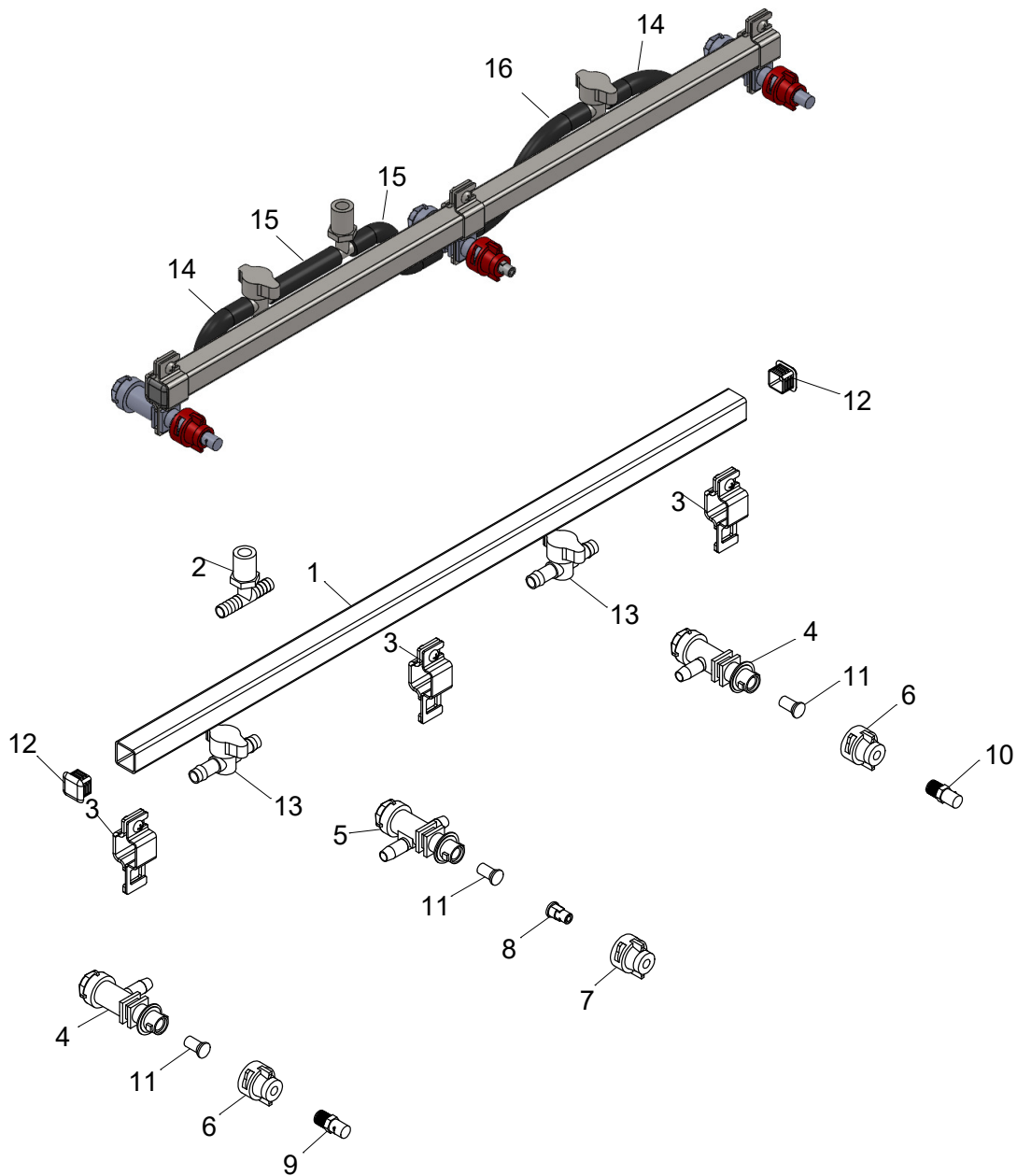

ITEM NO.	PART NUMBER	DESCRIPTION	QTY.	Note
1	5CS61020	Boom Tube 31"	1	
2	5CS43597	Tee 1/2" Barb - 1/2" NPT F	1	
3	5CS43598	Square Tube Clamp 1"	3	
4	5CS43658	Nozzle Body Single Hose 1/2"	2	
5	5CS43595	Nozzle Body Dual Hose 1/2"	1	

## Boomless 24' Spray

ITEM NO.	PART NUMBER	DESCRIPTION	QTY.	Note
6	5CS43599	Spray Tip Cap w/ Gasket for Threaded Tips	2	
7	5CS43408	Spray Tip Cap w/ Gasket	1	
8	5CS43410	Flood Spray Tip 0.3 gpm	1	
9	5CS43600	Boomless Flat Spray Tip Right	1	
10	5CS43601	Boomless Flat Spray Tip Left	1	
11	5CS43411	Spray Tip Screen	3	
12	5CS43401	Plastic End Cap 1"	2	
13	5CS43736	In-line Valve 1/2"	2	
14		1/2" Hose	2	CTL 3.25", MF 5CS43418
15		1/2" Hose	2	CTL 5", MF 5CS43418
16		1/2" Hose	1	CTL 10.25", MF 5CS43418
-	5CS43652	Hose Clamp Screw Type 3/8" - 1/2"	10	Not Illustrated

# BOLT TORQUE CHART

- Torque values listed are for general use only, based on the strength of the bolt or screw. DO NOT use these values if a different torque value or tightening procedures is given for a specific application. For plastic insert or crimped steel type lock nuts, for stainless steel, or for nuts on u-bolts, see the tightening instructions for the specific application.
- Fasteners must always be replaced with the same grade as specified in the manual parts list.
- Shear bolts are designed to fail under predetermined loads, always replace shear bolts with identical grades.
- Make sure fasteners threads are clean and start thread engagement properly.

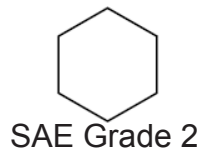
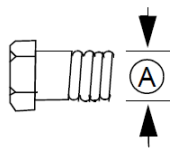

Diameter (A) (Inches)	Torque Values (Dry)					
	SAE Grade 2		SAE Grade 5		SAE Grade 8	
	N-m	lb-ft	N-m	lb-ft	N-m	lb-ft
1/4	7.4	5.5	12	9	17	12.5
5/16	15	11	24	18	35	26
3/8	27	20	45	33	62	46
7/16	43	32	70	52	102	75
1/2	68	50	108	80	156	115
9/16	95	70	156	115	217	160
5/8	136	100	217	160	305	225
3/4	238	175	380	280	540	400
7/8	238	175	615	455	870	640

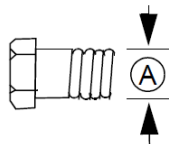

Diameter (A) (millimeters)	Torque Values (Dry)			
	Grade 8.8		Grade 10.9	
	N-m	lb-ft	N-m	lb-ft
M6	11.3	8.3	16.5	12.2
M8	27.5	20.3	40	29.5
M10	55	40	80	59
M12	95	70	140	105
M14	150	110	220	165
M16	240	175	350	255

**PART NUMBER**  
**5CS2004OM**

COPYRIGHT © 2020 Superior Tech Inc. Lancaster, PA All rights reserved

