

Agri+Fab[®]

Lawn Care Made Easy[®]

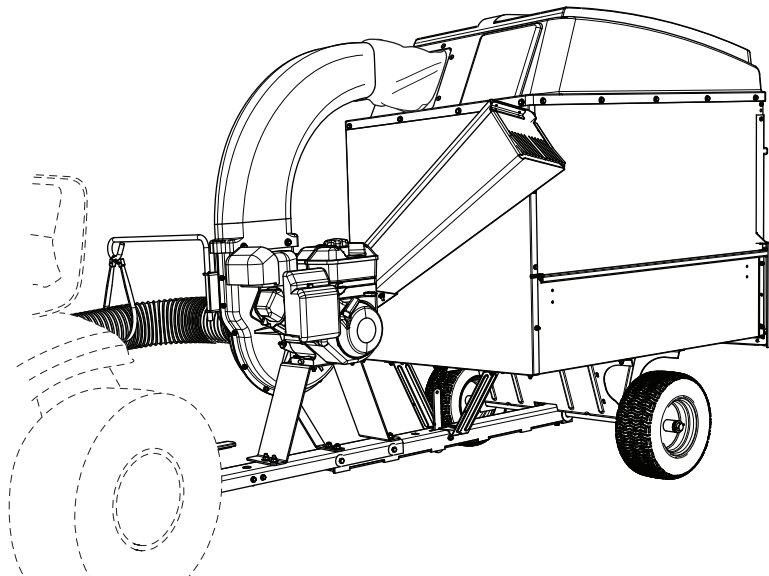

45-0578

CHIP-N-VAC

Want more information or assembly tips?



**Video
Instruction
Guide**

[youtube.com/c/agrifab](https://www.youtube.com/c/agrifab)

IMPORTANT: The engine is shipped without oil. Add oil before starting the engine.

IMPORTANT: The wheel bearings are not pre-lubricated. Fill the wheel hubs with grease after assembling the wheels to the axle.

TABLE OF CONTENTS

| | | | |
|--------------------------------|------|----------------------------------|----------|
| SAFETY RULES..... | 3,4 | SERVICE AND ADJUSTMENTS | 15 |
| FULL SIZE HARDWARE CHART | 5,10 | STORAGE | 15 |
| CARTON CONTENTS | 6 | TROUBLESHOOTING..... | 16 |
| ASSEMBLY | 7 | REPAIR PARTS ILLUSTRATIONS | 17,18,20 |
| OPERATION..... | 12 | REPAIR PARTS LISTS | 17,19,20 |
| MAINTENANCE | 14 | SLOPE GUIDE | 21 |

OPTIONAL ACCESSORY MODEL NO. 45-0253 12 FT. REMOTE HOSE KIT

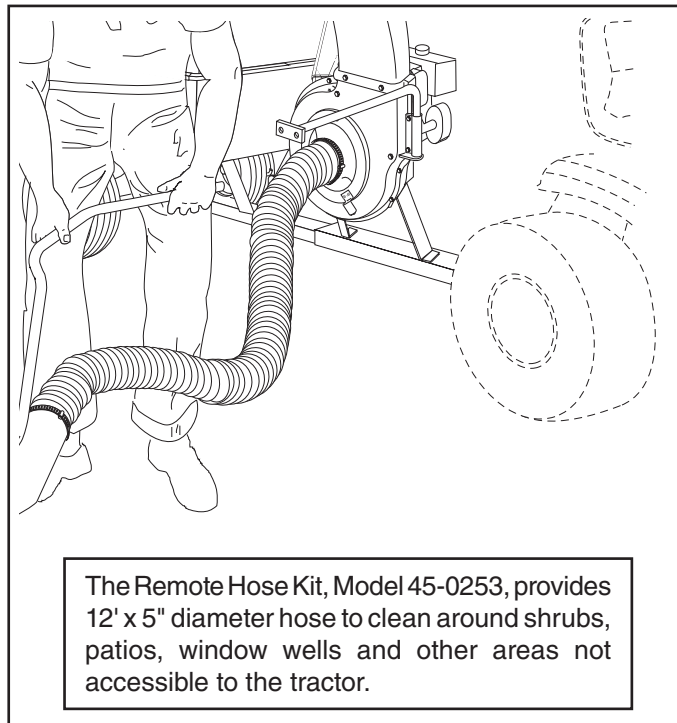



SAFETY



Any power equipment can cause injury if operated improperly or if the user does not understand how to operate the equipment. Exercise caution at all times, when using power equipment.

- Read and follow all instructions in this manual before attempting to assemble or operate this equipment. Failure to comply with these instructions may result in personal injury. Keep this manual in a safe place for future reference and for ordering replacement parts.
- Read this operating and service instruction manual carefully. Be thoroughly familiar with the controls and proper use of this power vacuum.
- Read the vehicle owners manual and vehicle safe operation rules before using this equipment.
- Never allow children under 16 to operate this Chip-N-Vac. Children 16 years and older should only operate under close parental supervision.
- Do not allow anyone to operate this equipment without proper instructions.
- Do not allow passengers to ride on this equipment or on the towing vehicle.
- Keep the area of operation clear of all persons, particularly small children. Also keep area clear of pets.
- Check fuel before starting engine. Do not fill fuel tank indoors, or when engine is running, or while engine is hot. Wipe off any spilled fuel before starting engine.
- Engine and muffler get hot. Do not touch! To avoid fire hazard, keep clean of debris and other accumulations.
- Never store Chip-N-Vac with fuel in tank. Allow engine to cool before storing in any enclosure.
- Do not change engine governor settings.
- Do not operate engine if air cleaner or cover is removed, except for adjustment. Removal of these parts could create a fire hazard.
- Keep hands, feet, face, long hair and clothing out of inlet and discharge area. There are ROTATING BLADES inside these openings.
- Before cleaning, repairing or inspecting, make certain all moving parts come to a complete stop. Disconnect spark plug wire and keep wire away from plug to prevent accidental starting. Keep throttle control lever in stop position.
- If the Chip-N-Vac should become blocked with debris at any point, shut engine off and wait until the impeller comes to a complete stop before attempting to remove the obstruction. Disconnect spark plug wire to prevent accidental starting.
- If the cutting mechanism strikes a foreign object, or if your Chip-N-Vac should start to vibrate abnormally, stop the engine immediately, disconnect the spark plug wire and move the wire away from the spark plug. Allow the machine to stop and take the following steps.
 - a. Inspect for damage.
 - b. Repair or replace any damaged parts.
 - c. Check for loose parts and tighten to assure continued safe operation.
- Check all bolts for tightness at frequent intervals to help insure safe operation.
- Check vinyl hard top boot frequently for wear. Replace if worn or damaged.
- Never operate Chip-N-Vac unless deck adapter, hose, hose adapter (nozzle), discharge chute (elbow), and top cover are properly attached in their place.
- Do not remove top cover or attempt to empty contents of cart while engine is running.
- Never attempt to change hose adapter (nozzle) or to install remote hose attachment when engine is running.
- Keep all shields and guards (e.g. discharge chute (elbow) and hose adapter (nozzle) in place and securely attached.
- Always wear safety glasses or other suitable eye protection when operating or maintaining this equipment.
- Do not stand behind cart in exhaust discharge area while engine is running.
- Do not operate this equipment while intoxicated or while taking drugs or medication that impairs the senses and reactions.
- When using this equipment, start with the vehicle transmission in first (low) gear and then gradually increase speed only as conditions permit.
- Operate this equipment at reduced speed on rough terrain, along creeks and ditches and on slopes to prevent tipping or loss of control. Do not drive too close to a creek or ditch.
- Vehicle braking and stability are affected by the addition of this equipment. Do not fill the Chip-N-Vac to its full capacity without checking the capability of the towing vehicle to safely pull and stop with the Chip-N-Vac attached.
- Before operating on any grade (hill) refer to the safety rules in the vehicle owner's manual concerning safe operation on slopes. Also refer to the SLOPE GUIDE on page 21 of this owner's manual. Do not operate on slopes in excess of 10 degrees. **STAY OFF STEEP SLOPES.**
- Follow the maintenance instructions outlined in this manual.



Look for this symbol to point out important safety precautions. It means — **Attention!! Become alert!! Your safety is involved.**



DANGER: This Chip-N-Vac was built to be operated according to the rules for safe operation in this manual. As with any type of power equipment, carelessness or error on the part of the operator can result in serious injury. This unit is capable of amputating fingers and hands and throwing objects. Failure to observe the following safety instructions could result in serious injury or death.

WARNING

TO AVOID SERIOUS INJURY

- Read Owner's Manual and all safety labels on machine before starting and using machine.
- Do Not remove top cover or attempt to empty contents of cart while engine is running.
- Do Not stand behind cart in exhaust discharge area while engine is running.
- Keep hands, feet, face, long hair and clothing out of chipper inlet, vac inlet, and discharge area. There are **ROTATING BLADES** inside these openings.
- Wear approved safety glasses and gloves. Avoid loose fitting clothes.
- Keep the area of operation clear of all persons, particularly small children and pets.
- Keep all shields and guards (e.g. upper chipper chute extension, discharge chute, nozzle assembly) in place and securely attached.
- Check discharge boot frequently for wear. Replace if worn or damaged.
- If unit becomes clogged or jammed, shut off engine right away. Do Not attempt to clear clog or jam with engine running.
- Muffler and engine get hot and can cause burns. Do Not Touch. To avoid a fire hazard, keep leaves, grass and other combustible debris off hot muffler and engine.
- Do Not attempt to remove or attach vac nozzle or optional Hose Kit with engine running.
- Do Not operate unit unless nozzle or optional Hose Kit is secured in place.
- Do Not fill gas tank while engine is running. Allow engine to cool at least 2 minutes before refueling.

46564



199682



M117554

DANGER

HAZARDOUS ROTATING BLADES INSIDE. KEEP HANDS AWAY FROM ALL OPENINGS. DO NOT REMOVE OR ATTACH HOSE, HOSE ADAPTER, ELBOW OR OPTIONAL HOSE KIT WHEN ENGINE IS RUNNING!

46565

46565



WARNING

This unit is equipped with an internal combustion engine and should not be used on or near unimproved forest-covered, or grass-covered land unless the engine's exhaust system is equipped with a spark arrester meeting applicable local or state laws (if any). If a spark arrester is used, it should be maintained in effective working order by the operator.

In the State of California the above is required by law (Section 4442 of the California Public Resources Code). Other states may have similar laws. Federal laws apply on federal lands. A spark arrester muffler is available at your nearest engine authorized service center.

HARDWARE PACKAGE CONTENTS

SHOWN FULL SIZE

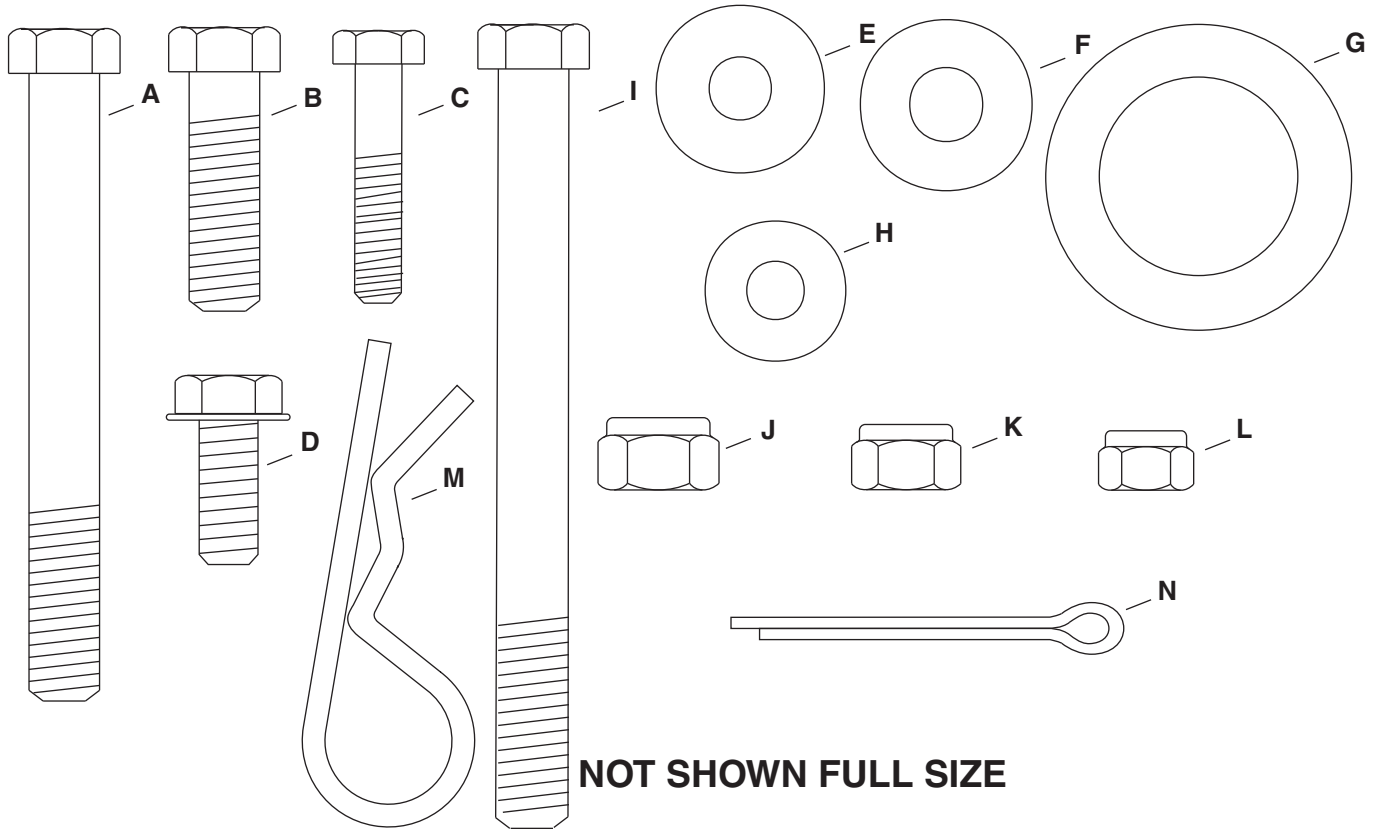

NOT SHOWN FULL SIZE

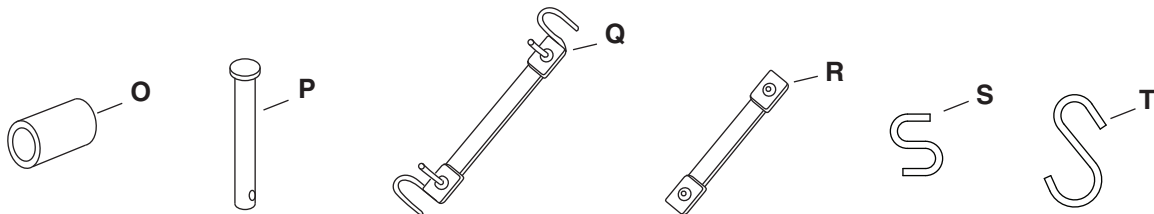

See page 10 for the Deck Adapter hardware package. (Contents not included here.)

| REF. | PART NO. | QTY | DESCRIPTION | REF. | PART NO. | QTY | DESCRIPTION |
|------|----------|-----|-----------------------------|------|----------|-----|------------------------------|
| A | 46938 | 4 | Bolt, Hex 3/8" x 3-1/4" | K | 47810 | 11 | Nylock Hex Nut, 5/16" |
| B | 43087 | 4 | Bolt, Hex 3/8" x 1-1/4" | L | 47189 | 11 | Nylock Hex Nut, 1/4" |
| C | 1509-90 | 3 | Bolt, Hex 1/4" x 1-1/4" | M | 43343 | 1 | Pin, Hair Cotter 1/8" |
| D | 47630 | 4 | Bolt, Hex 5/16" x 3/4" (ST) | N | 43093 | 2 | Pin, Cotter 1/8" x 1-1/2" |
| E | 1543-69 | 4 | Washer, Nylon | O | 44678 | 2 | Spacer Tube |
| F | 43081 | 29 | Washer, 3/8" | P | 49932 | 1 | Hitch Pin |
| G | 43601 | 4 | Washer, Flat 1" | Q | 43790 | 1 | Tarp Strap, 25" (with hooks) |
| H | 43088 | 11 | Flat Washer, 1/4" | R | 44850 | 2 | Tarp Strap |
| I | 710-0693 | 1 | Bolt, Hex 3/8" x 4" | S | 44849 | 2 | "S" Hooks |
| J | HA21362 | 11 | Nylock Hex Nut, 3/8" | T | 42749 | 1 | S" Hook (Large) |

CARTON CONTENTS

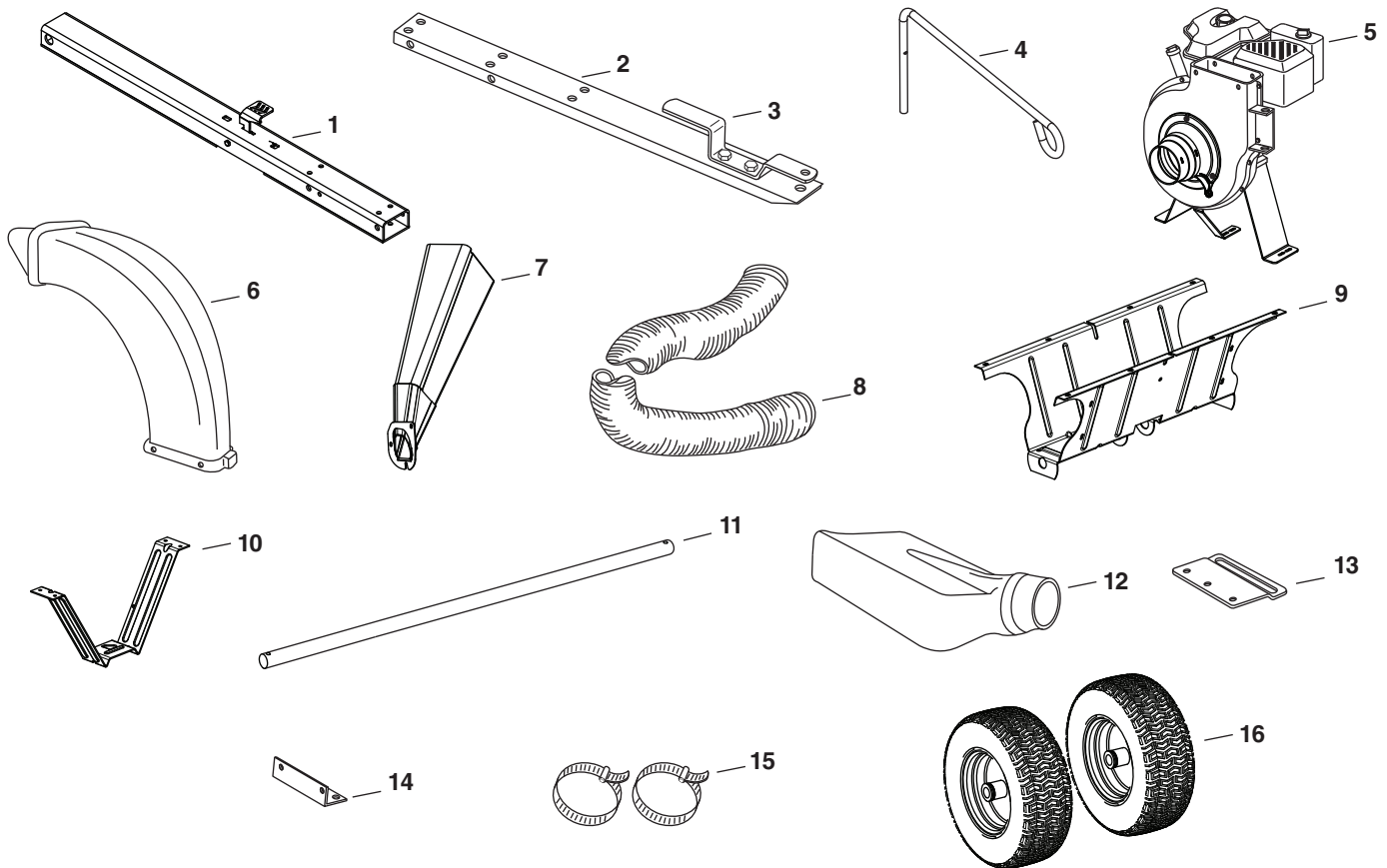

| REF. | PART NO. | QTY. | DESCRIPTION | REF. | PART NO. | QTY. | DESCRIPTION |
|------|----------|------|------------------------|------|----------|------|---------------------|
| 1 | ---- | 1 | Rear Tongue w/Latch | 9 | 23507BL3 | 1 | Wheel Support |
| 2 | ---- | 1 | Front Tongue Assembly | 10 | 24497BL1 | 1 | Latch Stand Bracket |
| 3 | ---- | 1 | Hitch Bracket | 11 | 24897 | 1 | Axle |
| 4 | 49974BL3 | 1 | Hose Hanger Rod | 12 | 43830 | 1 | Deck Adapter |
| 5 | ---- | 1 | Engine/Base Assembly | 13 | 23560BL1 | 1 | Adapter Bracket |
| 6 | 46420 | 1 | Elbow | 14 | 27304BL1 | 1 | Attachment Bracket |
| 7 | ---- | 1 | Chipper Chute Assembly | 15 | 43793 | 2 | Hose Clamp |
| 8 | 2-17 | 1 | Hose | 16 | 42159G | 2 | Wheels |

ASSEMBLY

This unit is shipped WITHOUT GASOLINE or OIL. After assembly, see separate engine manual for proper fuel and engine oil recommendations.

TOOLS REQUIRED FOR ASSEMBLY

- (1) Pliers
- (2) 7/16" Wrenches
- (2) 1/2" Wrench
- (2) 9/16" Wrenches

REMOVAL OF PARTS FROM CARTONS

1. Remove the hardware packs and all loose parts from the cartons.
2. Lay out and identify parts shown in carton contents.
3. Lay out and identify parts in the hardware packs. Keep contents of each hardware package separate.

ASSEMBLING THE CHIP-N-VAC

1. Tip the cart back to rest upright on the rear of the cart. See figure 1.
2. Attach the wheel support to the cart using eight 5/16" nylock nuts and 3/8" washers. See figure 1.

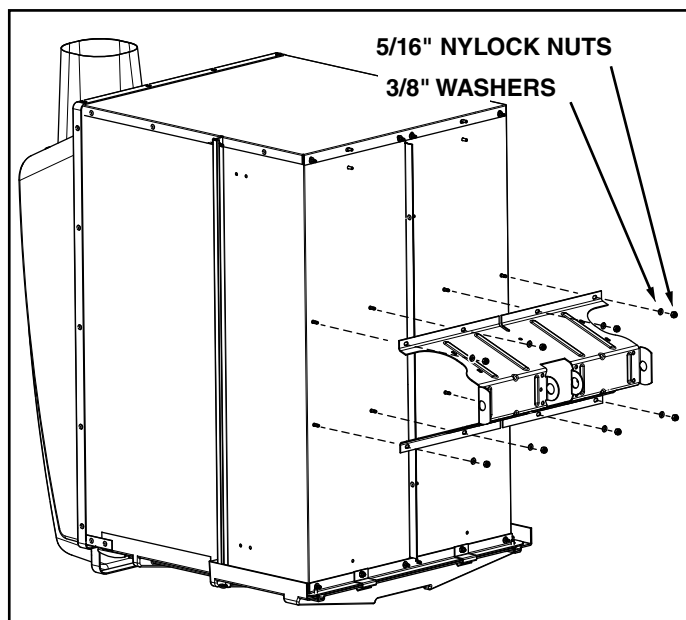

FIGURE 1

3. Attach the latch stand bracket (turned as shown) using four 1/4" nylock nuts and two 1/4" washers. Install the washers as shims underneath the latch stand bracket, on the two rear studs. See figure 2.

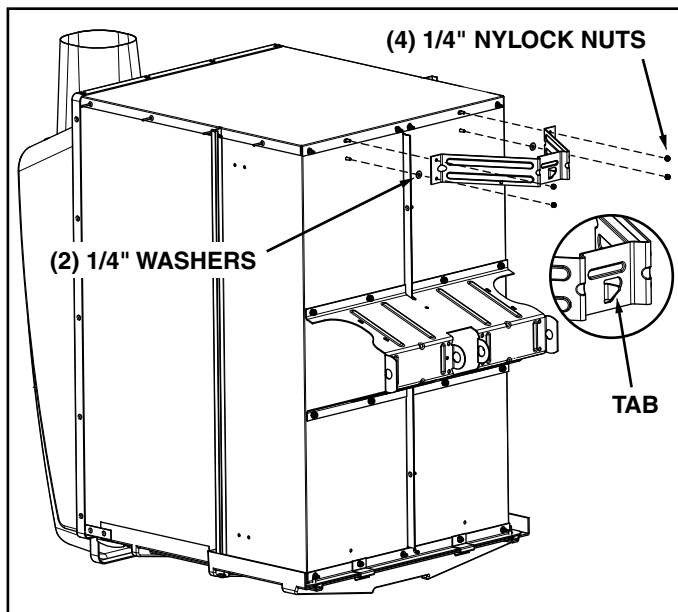

FIGURE 2

4. Install the rear tongue and the axle onto the cart body, sliding the axle through the wheel support and the tongue. Lock the tongue to the latch stand bracket with the foot pedal latch. See figure 3.

IMPORTANT: Make sure the tongue is securely locked to the latch stand bracket by the foot pedal latch.

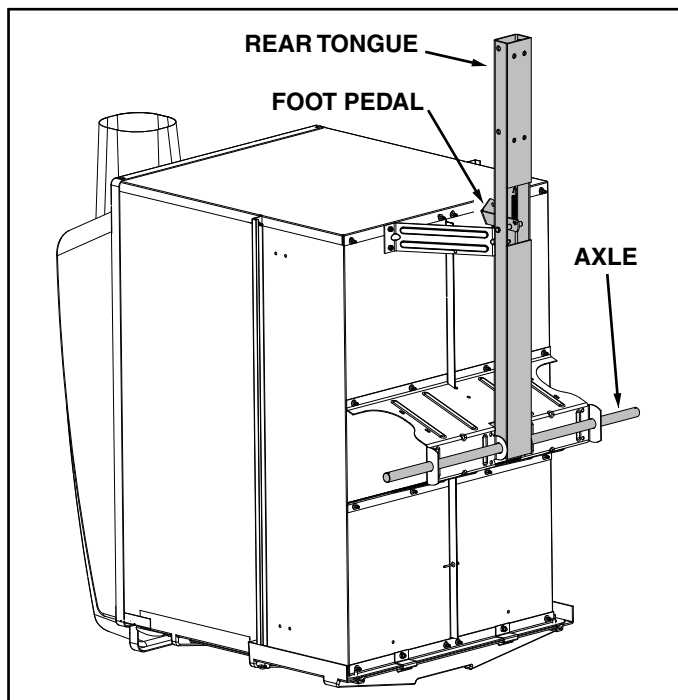

FIGURE 3

- Assemble a spacer tube, a 1" flat washer, a wheel (valve stem facing out), and another 1" flat washer onto the axle as shown in figure 4. Secure the wheel with a cotter pin, spreading the ends of the pin. Repeat on other end of axle.
- Pump grease into grease fittings on wheels until grease is forced out through ends of hubs.

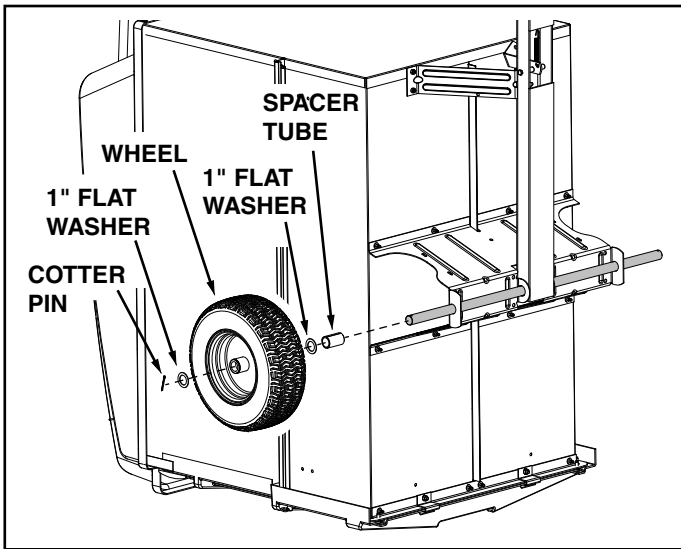

FIGURE 4

- Tip the cart forward so that it rests on its wheels.
- Assemble the front tongue on top of the rear tongue. In the front set of holes, attach using two 3/8" x 1-1/4" hex bolts, four 3/8" washers, and two 3/8" nylock nuts. In the rear holes use one 3/8" x 4" hex bolt, two 3/8" washers, and one 3/8" nylock nut. See figure 5.

HINT: For easier assembly, support the rear tongue with a block of wood.

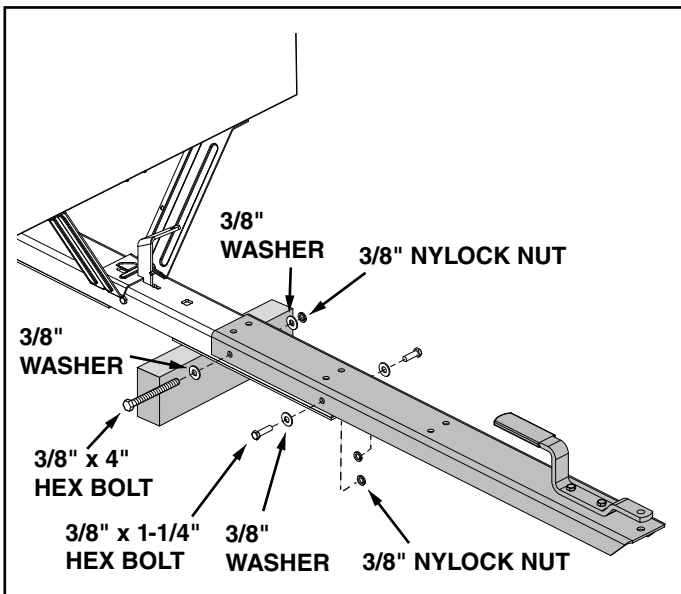

FIGURE 5

- Secure the hitch pin to the hitch bracket and tongue with the hair cotter pin. See figure 6.

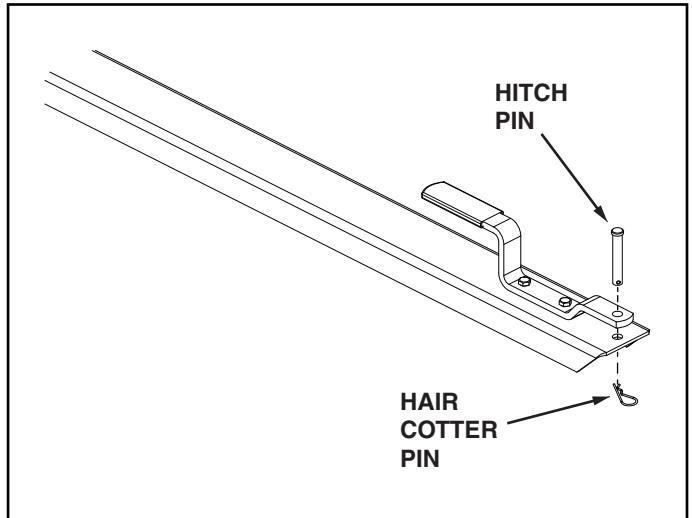

FIGURE 6

- Attach the engine base assembly to the tongue using four 3/8" x 3-1/4" hex bolts, two 3/8" x 1-1/4" hex bolts, twelve 3/8" washers and six 3/8" nylock nuts. **Tighten.** See figure 7.

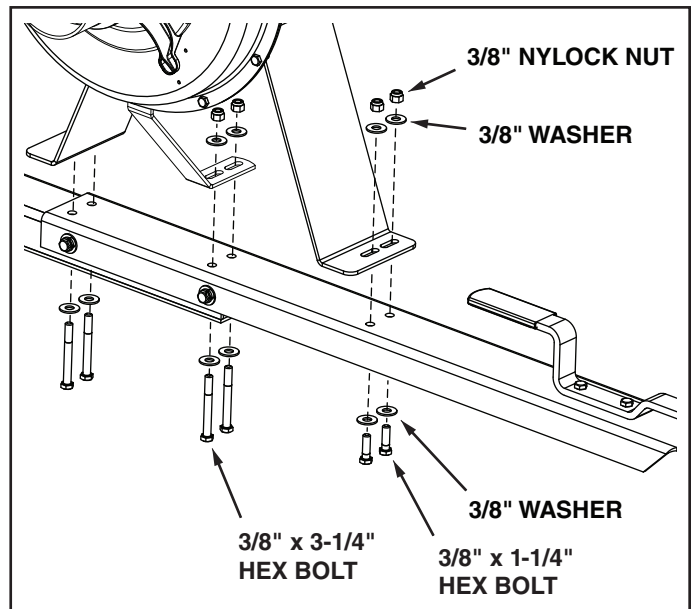

FIGURE 7

11. Assemble the elbow to the impeller housing using four 5/16" x 3/4" self tapping hex bolts and four nylon washers. Push while turning to help start the bolts into the unthreaded holes. **Tighten**. See figure 8.

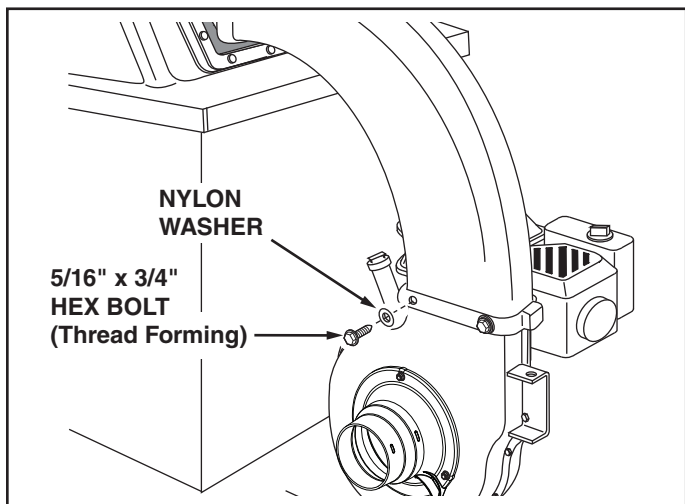

FIGURE 8

12. To align the elbow with the opening in the hard top:
 - a. Push the vinyl boot back inside the opening.
 - b. Loosen by approximately 1/2 turn each, the six bolts that you assembled that fasten the engine base to the tongue. See figure 9.
 - c. Slide the engine base assembly sideways until the elbow is aligned with the opening in the hardtop.
 - d. **Retighten** the six bolts that you loosened.
13. Pull the vinyl boot onto the end of the elbow.

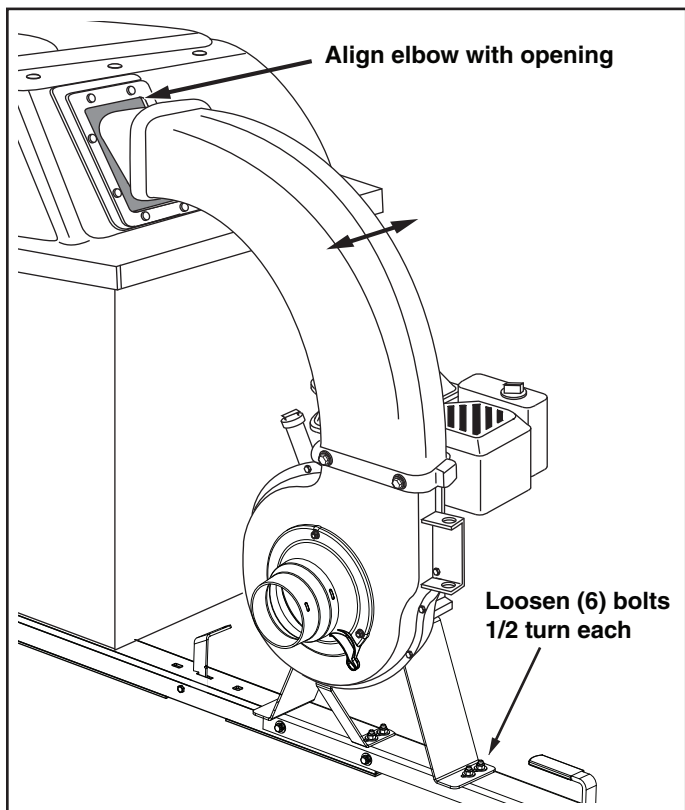

FIGURE 9

14. Place a hose clamp onto one end of hose. Push hose onto hose adapter (nozzle). Tighten hose clamp onto hose and hose adapter. **Do not** collapse hose adapter when tightening clamp. See figure 10.
15. Place the hose hanger rod into the hose hanger bracket on the impeller housing assembly. See figure 10.
16. Loop the 25" tarp strap under the hose. Hook to the hose hanger rod. See figure 10.

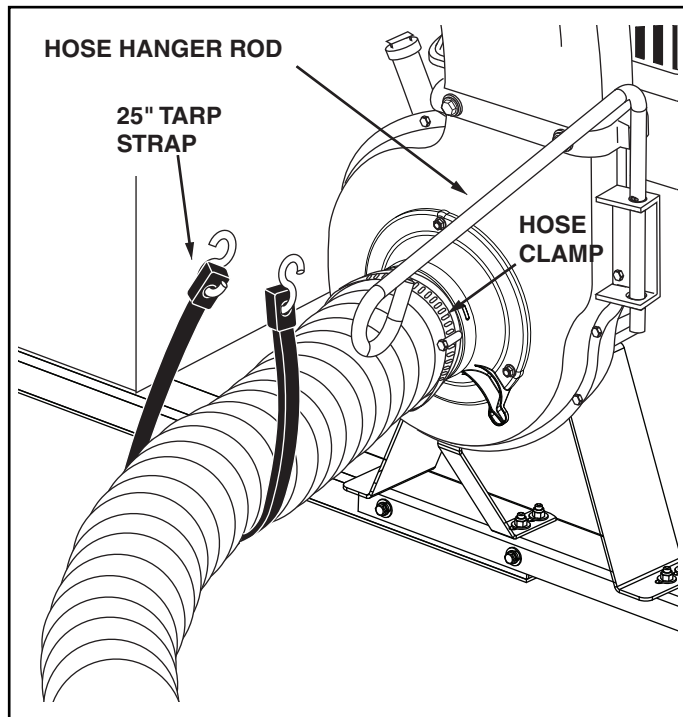

FIGURE 10

- HINT:** Tip the cart bed back for easier access.
17. Attach the chipper chute assembly to the weld bolts on the back side of the impeller housing using three 3/8" washers and 5/16" Nylock nuts. **Tighten**. See figure 11.

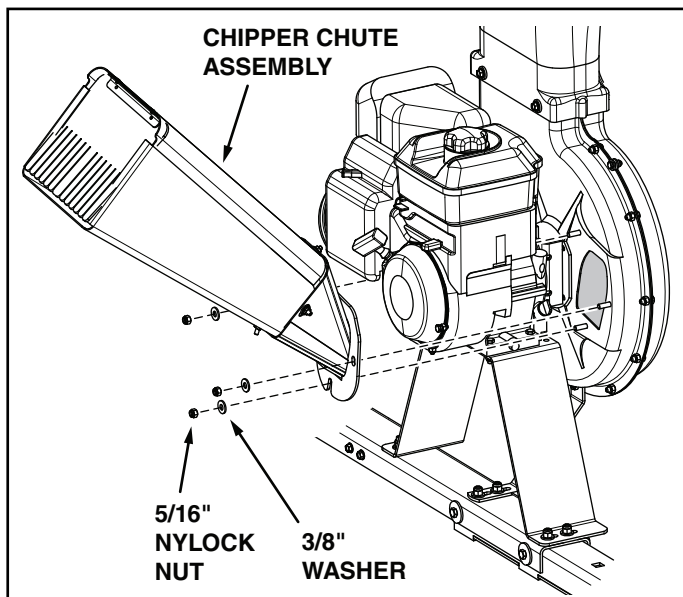

FIGURE 11



BEFORE PROCEEDING, look in the fold-out sheets to find the template for your mower deck. If written instructions are printed on the template, follow those instructions instead of the instructions in this manual.

ASSEMBLING THE DECK ADAPTER (#62468) TO THE MOWER DECK

Contents of Hardware Pack for Deck Adapter:
See Figure 12.

| REF. | PART NO. | QTY. | DESCRIPTION |
|------|----------|------|-----------------------------|
| A | 43840 | 2 | Hex Bolt, 5/16" x 1-1/4" |
| B | 43661 | 4 | Hex Bolt, 1/4" x 1" |
| C | 43080 | 2 | Carriage Bolt, 5/16" x 3/4" |
| D | 47810 | 3 | Nylock Nut, 5/16" |
| E | 1543-69 | 5 | Nylon Washer |
| F | 23825 | 1 | Mounting Strap |
| G | 23826 | 1 | Angle Bracket |
| H | 23827 | 1 | Mounting Bracket |

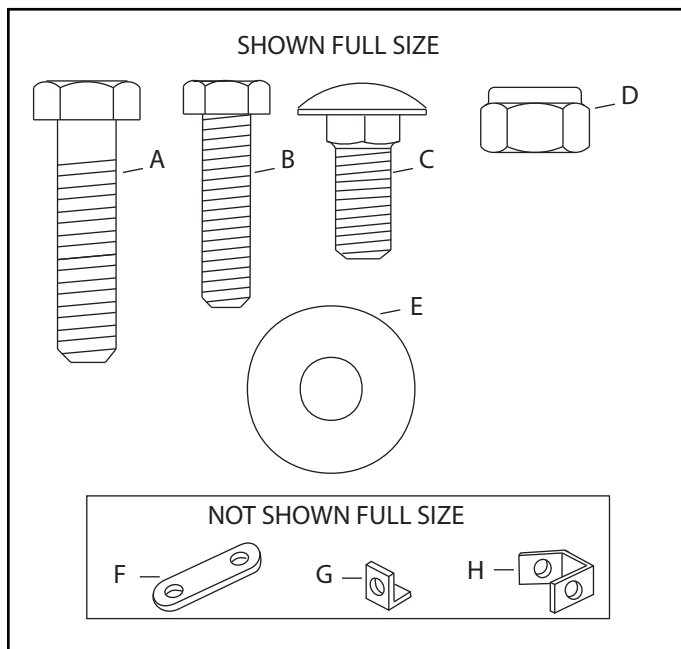

FIGURE 12- FULL SIZE

NOTE: Not all of the hardware will be used for any one particular fit up.

1. Identify and cut out the template for your **brand and size** mower deck. If there is no template included for your deck size, you can make your own template by marking around a piece of cardboard held against the edge of the deck's discharge opening.
2. **FOLLOW THE INSTRUCTIONS PRINTED ON THE TEMPLATE.** If there are no instructions, use the following instructions as a general guide.
3. Tape the template to the face of the adapter, about 1/2" from front and 1/4" down from top for deeper decks. For shallow decks, position template low enough that adapter will not extend below bottom of deck. Mark outline of template on face of adapter using white crayon, nail or scribe. Drill a starting hole inside the outline, then use a saber saw or key hole saw to cut out the opening. See figure 13.

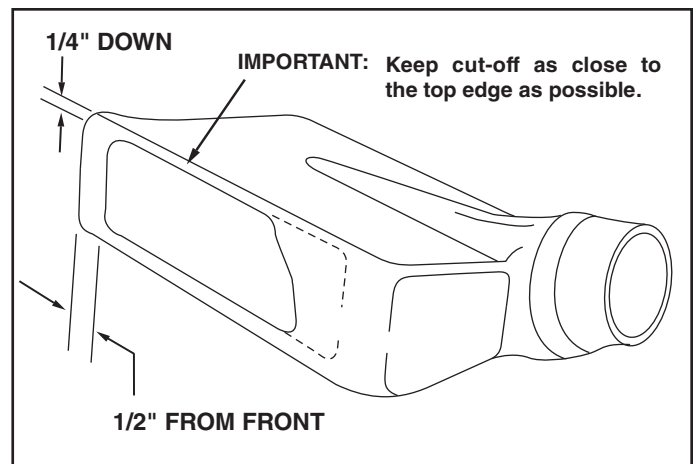

FIGURE 13

PERFORM THIS STEP ONLY IF NECESSARY.

4. Remove the mower discharge deflector from your mower deck if necessary to attach deck adapter. Save the deflector and hardware for remounting deflector.



CAUTION: Mower deflector must be replaced when Vac System deck adapter is removed. Do Not operate mower unless adapter or deflector is in place and properly mounted.

- Position the adapter over the deck opening, and check for fit of cutout as shown in figure 14. Trim cutout, if necessary, to allow tilting of adapter, keeping the fit as close as possible for best vacuum suction.

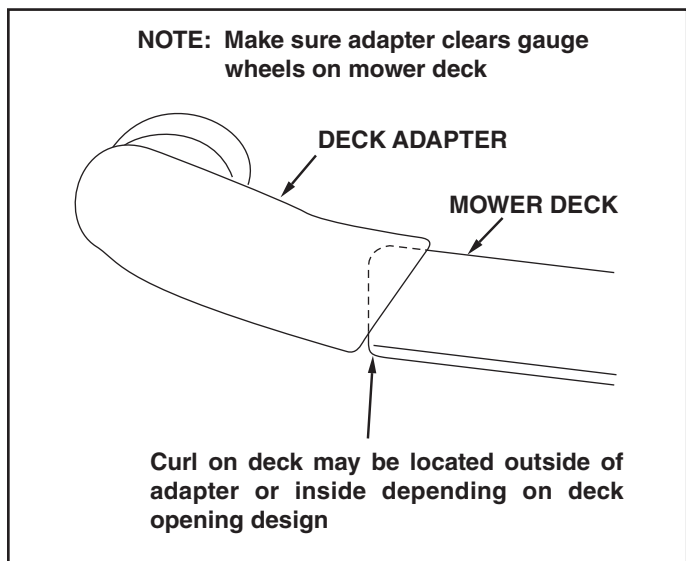

FIGURE 14

- Holding the adapter bracket and the deck adapter together, position the deck adapter on the mower deck. Keeping the edge of deck adapter as close as possible to the offset in the adapter bracket, see if the slot in the adapter bracket can be aligned with one or two of the deflector holes in your mower deck's discharge opening. If the bracket can not be located correctly using existing holes, it will be necessary to drill one or two 5/16" diameter holes in the deck. See figure 15.

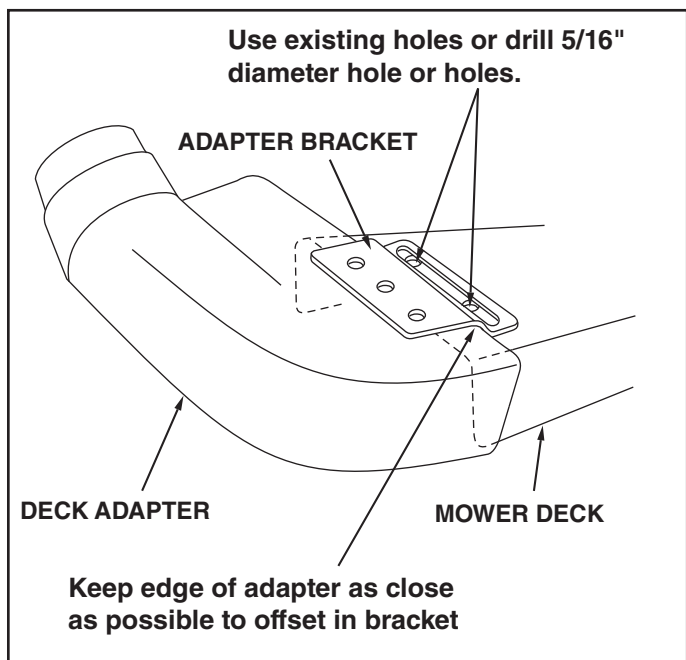

FIGURE 15

- Assemble the adapter bracket to the deck using two 5/16" x 1-1/4" hex bolts, 5/16" flat washers and 5/16" nylock nuts. See figure 16.

NOTE: It may be necessary to use extra 5/16" flat washers to shim under the bracket next to the deck surface. Ten extra washers have been furnished as shims. See figure 16.

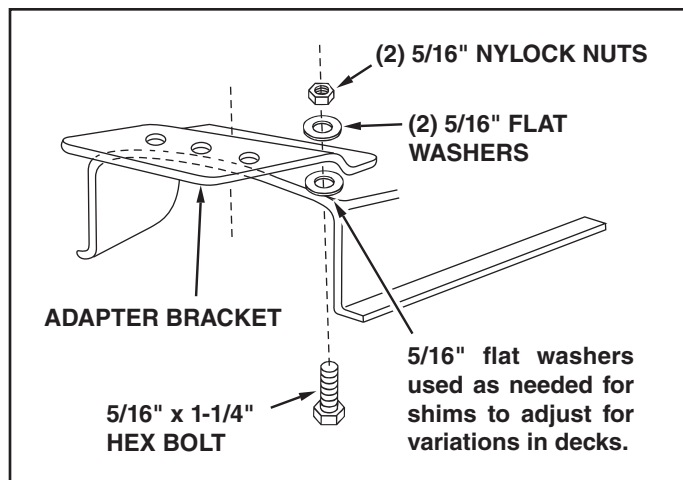

FIGURE 16

- With deck adapter positioned correctly over the discharge opening, use the adapter bracket as a template and drill three 9/32" diameter holes in the top of the deck adapter. See figure 17.
- Bolt deck adapter to bracket using three 1/4" x 1" bolts, nylon washers, 1/4" flat washers and 1/4" lock nuts. Nylon washers should be against the inside of the deck adapter. See figure 17.

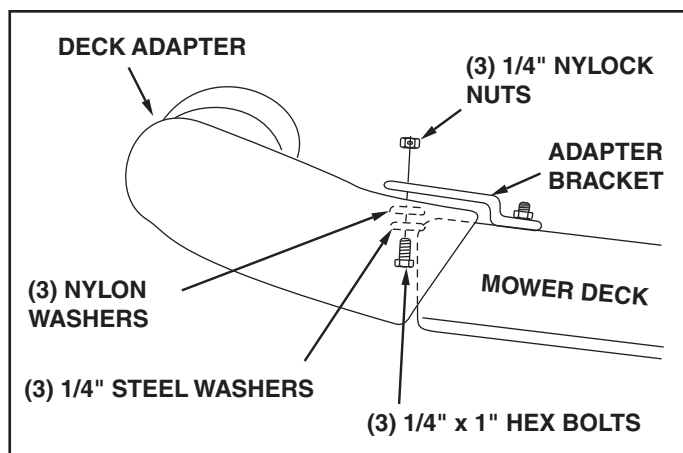

FIGURE 17

- Assemble end of hose and a hose clamp over the round opening of deck adapter and tighten clamp.

OPERATION

BEFORE STARTING

1. Your Chip-N-Vac engine is shipped without oil or gasoline. Service the Chip-N-Vac engine with oil and gas as instructed in the separate engine manual.
2. Inspect the Chip-N-Vac to make sure all covers (rear door, vinyl boot, elbow, hose adapter, hose and deck adapter) are properly attached.
3. Check tires for proper inflation (12 - 14 lbs). **Do not exceed** the maximum pressure printed on the side of the tires.



WARNING: Never fill fuel tank indoors, or with the engine running, or while the engine is hot. Do not smoke while filling tank.

HOW TO STOP YOUR CHIP-N-VAC

1. To stop engine, move the throttle control lever to the OFF position.
2. Disconnect spark plug wire from plug to prevent accidental starting while equipment is unattended or is being worked on.



CAUTION: The muffler and adjacent areas are hot!

HOW TO START YOUR CHIP-N-VAC



WARNING: Never start or run the engine without all covers being properly attached to the blower housing and cart.

1. Check oil and gas in Chip-N-Vac engine.
2. Attach spark plug wire to spark plug.
3. Move choke lever on engine to CHOKE position. (A warm engine may not require choking.)
4. Move throttle control lever on engine to FAST position.
5. Grasp starter handle and pull rope out slowly until engine reaches start of compression cycle (rope will pull slightly harder at this point). Let the rope rewind slowly.
6. Pull rope with a rapid, continuous, full arm stroke. Keep a firm grip on starter handle. Let rope rewind slowly. Do not let starter handle snap back against starter.
7. Repeat instructions in two preceding paragraphs until engine fires. When engine starts, move choke control gradually to RUN position.

HOW TO USE YOUR CHIP-N-VAC



CAUTION: Vehicle braking and stability may be affected with the addition of an accessory or an attachment. Be aware of changing conditions on slopes.

1. Begin operation at low speed, adjusting forward speed to match grass height and/or moisture condition to prevent clogging.
2. Do not attempt to vacuum up any material other than vegetation found in a normal yard, such as light branches, leaves, twigs, etc.



WARNING: Should your Chip-N-Vac become clogged, shut off tractor and Chip-N-Vac engines. Before attempting to unclog, remove wire from spark plug to prevent accidental starting.

3. To empty cart, shut off tractor engine and set brake.
4. Shut off Chip-N-Vac engine.
5. Remove rear door from cart.
6. Release the latch holding cart down to the tongue by stepping on the foot pedal latch. See figure 18.
7. Using a rake or suitable tool, pull the grass clippings and/or leaves out of cart.



CAUTION: To avoid possible injury, be sure that no one is near the cart before releasing the latch.

8. After cart is emptied, secure cart to tongue with latch and reattach the rear door and the vinyl boot.

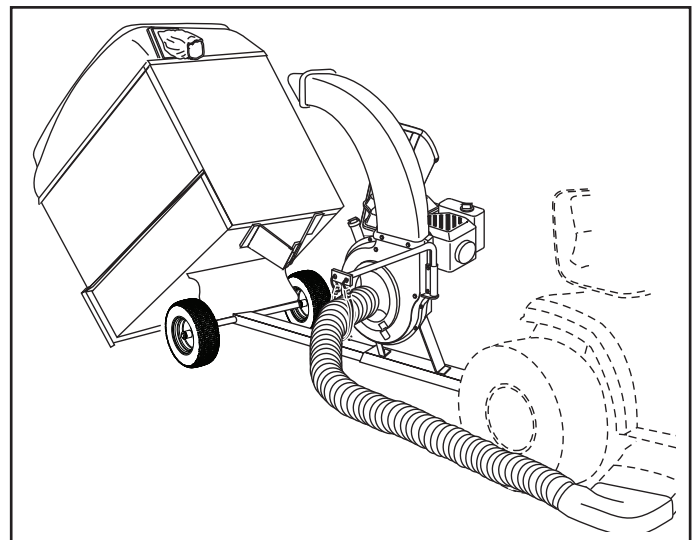

FIGURE 18

USING THE CHIPPER CHUTE

1. Material such as stalks or heavy branches up to 2" in diameter may be fed into the chipper chute as shown in figure 19.
2. Be sure to wear eye protection and gloves when feeding material into the chipper chute.
4. For best performance, it is important to keep the chipper blades sharp. If the composition of the material being discharged changes (becomes stringy, etc.) or if the rate of discharge slows down considerably, it is likely that the chipper blades are dull and need to be sharpened or replaced. Refer to the Service and Adjustments section, on page 15.



WARNING: Do not attempt to feed any material larger than 2" in diameter into the chipper chute. Personal injury or damage to the machine could result.



DANGER: Keep hands out of chipper chute. Rotating blades in impeller housing can cause serious injury. Use the tamper plug to help push material down into the chute.

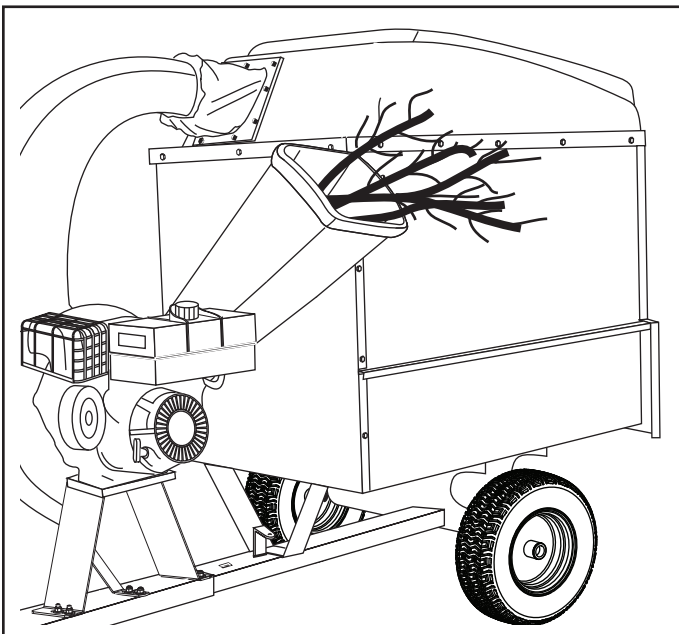

FIGURE 19

MAINTENANCE

CUSTOMER RESPONSIBILITIES

- Read and follow the maintenance schedule and the maintenance procedures listed in this section.

| MAINTENANCE SCHEDULE Fill in dates as you complete regular service. | Service Dates | | | | | | | | | | | |
|---|-----------------|----------------|--------------|----------------|--|--|--|--|--|--|--|--|
| | Before each use | After each use | Every season | Before storage | | | | | | | | |
| Check for loose fasteners | X | | | | | | | | | | | |
| Check soft vinyl boot | X | | | | | | | | | | | |
| Check tire pressure | X | | | | | | | | | | | |
| Check engine oil level | X | | | | | | | | | | | |
| Lubricate | | | X | | | | | | | | | |
| Clean | | X | | X | | | | | | | | |

Maintain engine per instructions below and in engine manual.

BEFORE EACH USE

CHECK FOR LOOSE FASTENERS

1. Make a thorough visual check of the Chip-N- Vac for any bolts and nuts which may have loosened. Retighten any loose bolts and nuts.

CHECK VINYL BOOT

2. Check the soft vinyl boot (on front of hard top) for wear. Replace if worn or damaged.

CHECK TIRE PRESSURE

3. Check tire pressure regularly. Recommended tire pressure is 12-14 Lbs. **Do not exceed** the maximum pressure listed on the side of the tires.

CHECK ENGINE OIL LEVEL

4. Check oil level before each use. Maintain engine oil as instructed in the separate engine manual.

LUBRICATION

1. At the beginning of each season, lubricate the latch, latch pivot bolt, and the axle where the hitch tongue pivots, with a light machine oil.
2. At least once a season, grease or oil the wheel bearings. Use automotive wheel bearing type grease or 20 weight oil.



WARNING: Always stop engine and disconnect spark plug wire before cleaning, lubricating or before performing any repairs or maintenance.

ENGINE MAINTENANCE

Always use STA-BIL® 360 Performance in every tank to prevent ethanol related fuel problems. STA-BIL® is the only approved fuel stabilizer for use in Agri-Fab equipment.

Only use high quality detergent oil rated with API service classification SF or SG. Select the oil's SAE viscosity grade according to your expected operating temperature. SAE 30 grade oil is recommended for warm weather use. For cold weather use refer to the engine manufacturer's Operating and Maintenance Manual.

1. Check **oil level** before each use. Maintain engine oil as instructed in the separate engine manual.
2. Service **air cleaner** every 25 hours under normal conditions. Clean every few hours under extremely dusty conditions. Poor engine performance and flooding usually indicates that the air cleaner should be serviced. To service the air cleaner, refer to the separate engine manual.
3. The **spark plug** should be cleaned and the gap reset once a season. Spark plug replacement is recommended at the start of each season. Check the engine manual for correct plug type and gap specifications.

CLEANING

1. Make sure the cart, the side and front panels and top are cleaned after each use. Grass clippings and leaves left in the cart will mildew and cause damage if not cleaned out.
2. **Clean the engine** regularly with a cloth or brush. Keep the cooling fins on the engine housing clean to permit proper air circulation which is essential to engine performance and life. Be sure to remove all dirt and debris from muffler area.

SERVICE AND ADJUSTMENTS

SHARPENING OR REPLACING CHIPPER BLADES

1. Disconnect the spark plug wire and move wire away from the spark plug.
2. Remove the access plate by removing two hex lock nuts. See figure 20.
3. Locate one of the chipper blades in the access plate opening by rotating the impeller assembly by hand. Remove the blade using a 3/16" allen wrench on the outside of the blade and a 1/2" wrench on the impeller assembly, inside the housing.
4. Remove the other blade in the same manner.
5. Replace or sharpen blades. If sharpening, make certain to remove an equal amount from each blade. Reassemble in reverse order.

NOTE: Make certain the blades are reassembled with the sharp edge facing upward, as viewed from the access plate opening.

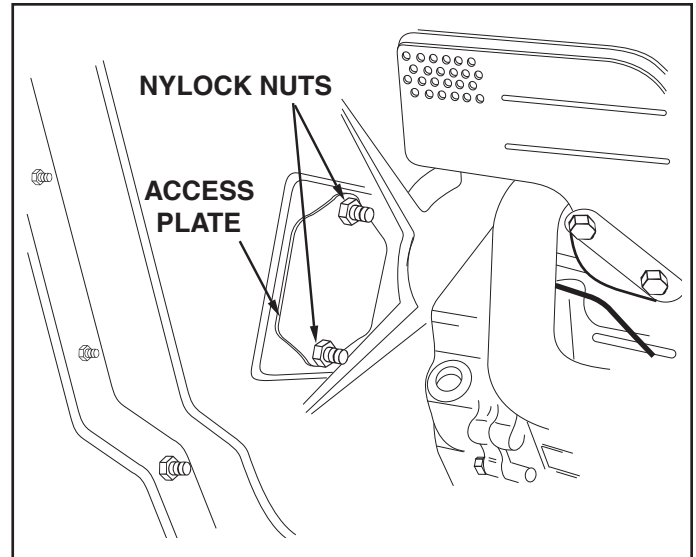

FIGURE 20

REMOVING THE IMPELLER

1. To remove an impeller that is frozen on the shaft, order the Impeller Service Tool (part #42294) that is listed on the parts ordering page 20.
2. Remove the bolt that holds the impeller on the shaft and screw the impeller service tool into the hole until the impeller breaks free.

STORAGE

1. Clean the engine and the entire unit thoroughly.
2. Refer to engine manual for correct engine storage instructions.
3. If storing in an unventilated or metal storage shed, coat metal parts with light oil or silicone to prevent rust.
4. Store unit in a clean, dry area.

It is important to prevent gum deposits from forming in essential fuel system parts such as the carburetor, fuel filter, fuel hose or tank during storage. Also, alcohol blended fuels (called gasohol or using ethanol or methanol) can attract moisture which leads to separation and formation of acids during storage. Acidic gas can damage the fuel system of an engine while in storage.

To avoid engine problems while in storage of 30 days or longer, fill the fuel tank to the top with fresh fuel treated with STA-BIL® fuel additive to keep the fuel fresh and make sure it starts next season. Once fuel is treated, run engine for 2 minutes to circulate stabilized fuel.

TROUBLESHOOTING

| PROBLEM | POSSIBLE CAUSE(S) | CORRECTIVE ACTION |
|--|---|--|
| Engine fails to start | <ol style="list-style-type: none"> 1. Spark plug wire disconnected. 2. Safety switch not contacted. 3. Fuel tank empty, or stale fuel. 4. Fuel shut-off valve closed (if so equipped). 5. Faulty spark plug. | <ol style="list-style-type: none"> 1. Connect wire to spark plug. 2. Correctly install hose adapter nozzle. 3. Fill tank with clean, fresh fuel. 4. Open fuel shut-off valve. 5. Clean, adjust gap or replace. |
| Loss of power; operation erratic. | <ol style="list-style-type: none"> 1. Spark plug wire loose 2. Unit running on CHOKE. 3. Blocked fuel line or stale fuel. 4. Water or dirt in fuel system. 5. Carburetor out of adjustment. 6. Dirty air cleaner. | <ol style="list-style-type: none"> 1. Connect and tighten spark plug wire. 2. Move choke lever to OFF position. 3. Clean fuel line; fill tank with clean fresh gasoline. 4. Disconnect fuel line at carburetor to drain fuel tank. Refill with fresh fuel. 5. Adjust carburetor.* 6. Service air cleaner.* |
| Engine overheats | <ol style="list-style-type: none"> 1. Carburetor not adjusted properly. 2. Engine oil level low. | <ol style="list-style-type: none"> 1. Adjust carburetor.* 2. Fill crankcase with proper oil. |
| Too much vibration | Loose parts or damaged impeller. | Stop engine immediately and disconnect spark plug wire. Tighten all bolts and nuts. Make all necessary repairs. If vibration continues, have unit serviced by an authorized service dealer. |
| Unit does not discharge | <ol style="list-style-type: none"> 1. Discharge chute (elbow) clogged. 2. Foreign object lodged in impeller. 3. Chip-N-Vac cart is full. | <ol style="list-style-type: none"> 1. Stop engine immediately and disconnect spark plug wire. Clean inside of housing and discharge chute (elbow). 2. Stop engine immediately and disconnect spark plug wire. Remove lodged object. 3. Empty cart. |
| Rate of discharge when chipping slows considerably, or composition of discharged material changes. | Chipper blades dull. | Sharpen or replace chipper blades. |

*Refer to the engine manual packed with your unit.

NOTE: For repairs beyond the minor adjustments listed above, please contact your nearest authorized service dealer.

PARTS

REPAIR PARTS FOR MODEL 45-0578 CART BODY

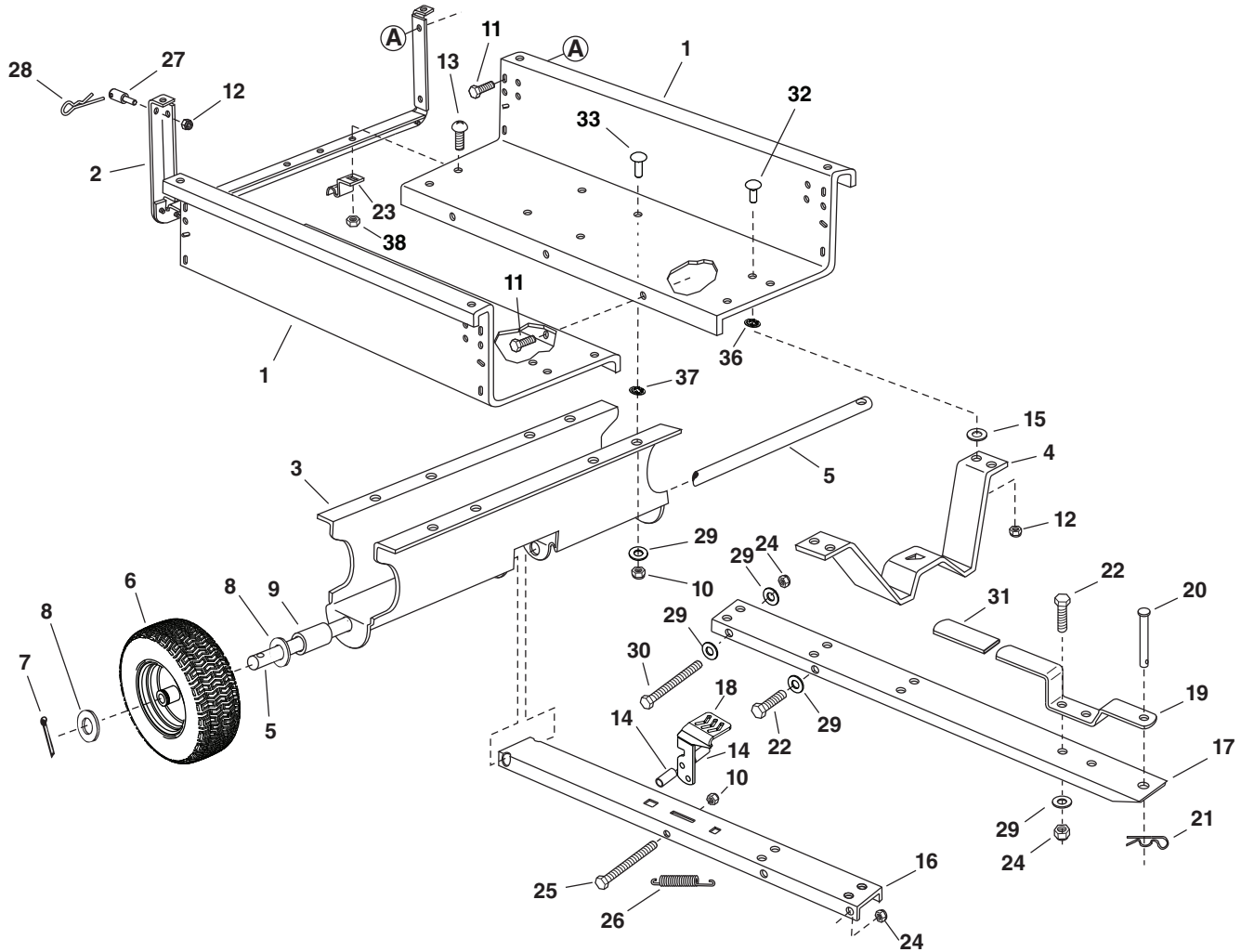

| REF. | PART NO. | QTY. | DESCRIPTION | REF. | PART NO. | QTY. | DESCRIPTION |
|------|----------|------|--------------------------------|------|----------|------|------------------------------|
| 1 | 23985BL3 | 2 | Cart Body | 20 | 49932 | 1 | Clevis Pin, 1/2" x 3" |
| 2 | 62458 | 1 | Tailgate Reinforcement Bracket | 21 | 43343 | 1 | Pin, Hair Cotter 1/8" |
| 3 | 23507BL3 | 1 | Wheel Support | 22 | 43087 | 4 | Hex Bolt, 3/8-16 x 1-1/4" |
| 4 | 24497BL1 | 1 | Latch Stand Bracket | 23 | 23838 | 2 | Door Support |
| 5 | 24897 | 1 | Axle, Wheel 1" Dia. | 24 | HA21362 | 5 | Nut, Hex Nylock 3/8-16 |
| 6 | 42159G | 2 | Wheel w/Tire, 15 x 6.00 | 25 | 47407 | 1 | Hex Bolt, 5/16-18 x 4" |
| 7 | 43093 | 2 | Cotter Pin, 1/8" Dia. x 1-1/2" | 26 | 47408 | 1 | Spring, Extension |
| 8 | 43601 | 4 | Washer, Flat 1" | 27 | 42999 | 2 | Pin |
| 9 | 44678 | 2 | Spacer Tube, 1-1/4" x 2" Lg. | 28 | 48934 | 2 | Hairpin |
| 10 | 47810 | 9 | Hex Nut, 5/16-18 Nylock | 29 | 43081 | 14 | Washer, 3/8" |
| 11 | 48373 | 9 | Pop Rivet | 30 | 710-0693 | 1 | Bolt, Hex 3/8" x 4" |
| 12 | 47189 | 6 | Hex Nut, 1/4-20 Nylock | 31 | 47707 | 1 | Grip |
| 13 | 43814 | 2 | Truss Hd. Bolt, 5/16-18 x 3/4" | 32 | 44950 | 4 | Carriage Bolt, 1/4-20 x 3/4" |
| 14 | 41076 | 2 | Spacer | 33 | 45542 | 8 | Carriage Bolt 5/16-18 x 1" |
| 15 | 43088 | 2 | Washer, Flat 1/4" | 34 | 28546BL1 | 2 | Strap, Latch Stand Anchor |
| 16 | 69688BL3 | 1 | Tongue Ass'y. (Rear) | 35 | 28547BL1 | 4 | Strap, Wheel Support Anchor |
| 17 | 27863BL3 | 1 | Tongue (Front) | 36 | 45541 | 4 | 1/4" Retainer |
| 18 | 28258BL3 | 1 | Latch, Foot Pedal | 37 | M84309 | 8 | Retainer Nut |
| 19 | 27264BL1 | 1 | Hitch Bracket | 38 | 46980 | 2 | Hex Nut, 5/16-18 Sims |

REPAIR PARTS FOR MODEL 45-0578 CHIP-N-VAC

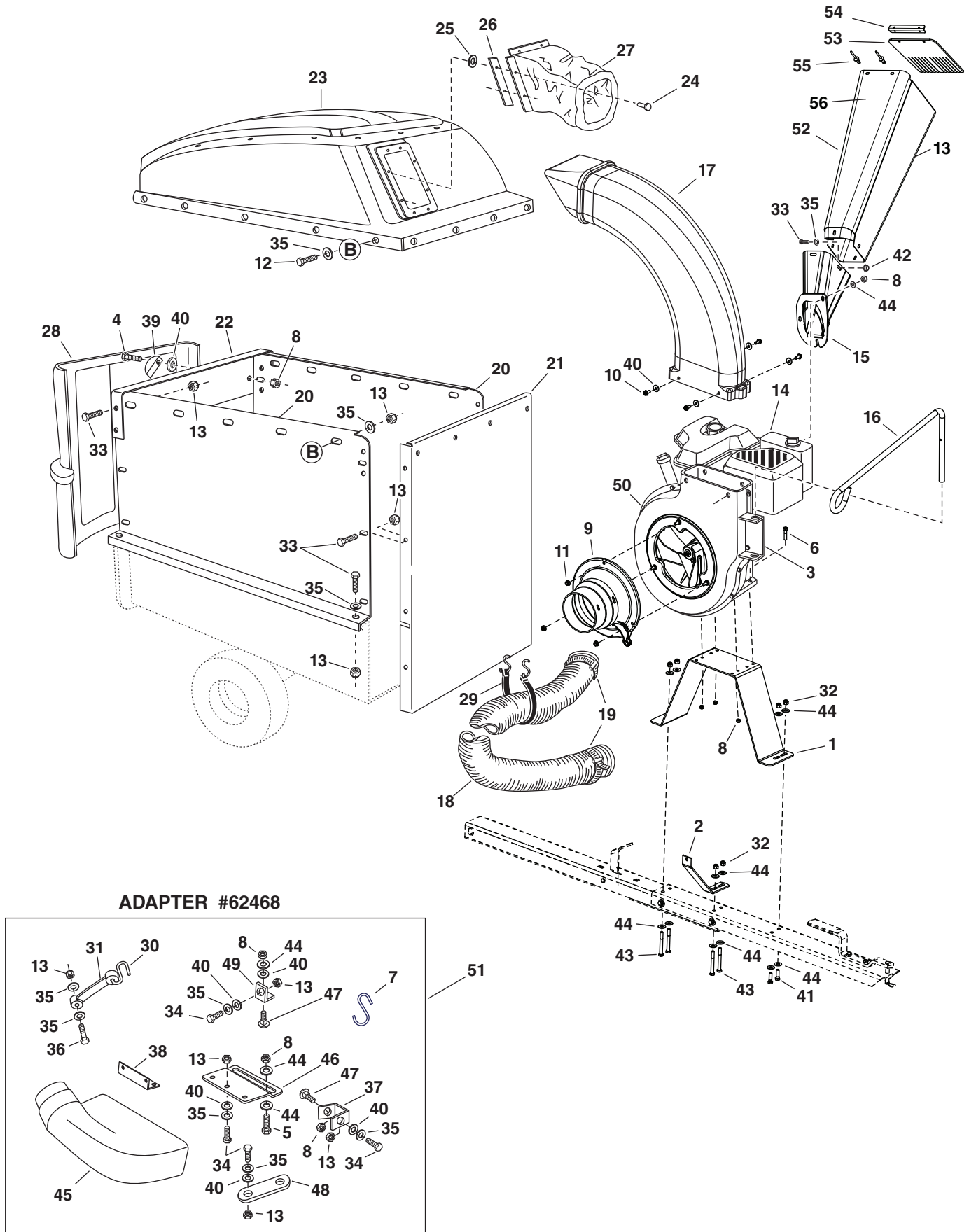

REPAIR PARTS FOR MODEL 45-0578 CHIP-N-VAC

| REF. | PART NO. | QTY. | DESCRIPTION | REF. | PART NO. | QTY. | DESCRIPTION |
|------|----------|------|---|------|----------|------|---|
| 1 | 27883BL3 | 1 | Engine Base | 31 | 44850 | 2 | Strap, Tarp (Less Hooks) |
| 2 | 27882BL3 | 1 | Brace, Housing | 32 | HA21362 | 6 | Nut, Hex Nylock 3/8-16 |
| 3 | 24958BL1 | 1 | Hose Hanger Bracket | 33 | 43866 | 4 | Bolt, Hex 1/4-20 x 5/8" |
| 4 | 43182 | 2 | Bolt, Hex 5/16-18 x 3/4" | 34 | 43661 | 4 | Bolt, Hex 1/4-20 x 1" |
| 5 | 43840 | 2 | Bolt, Hex 5/16-18 x 1-1/4" | 35 | 43088 | 15 | Washer, 1/4" STD |
| 6 | 43085 | 4 | Bolt, Hex 5/16-18 x 1-1/2" | 36 | 1509-90 | 3 | Bolt, Hex 1/4-20 x 1-1/4" |
| 7 | 42749 | 1 | "S" Hook, Large | 37 | 23827 | 1 | Mounting Bracket |
| 8 | 47810 | 12 | Nut, Nylock 5/16-18 | 38 | 27304BL1 | 1 | Bracket, Attachment |
| 9 | 43791 | 1 | Hose Adapter (Nozzle) | 39 | 23789 | 2 | Door Latch |
| 10 | 47630 | 4 | Screw, Self Tap 5/16-18 x 3/4" | 40 | 1543-69 | 11 | Washer, Nylon 21/64" |
| 11 | 49983 | 3 | Hex Nut, Flange Lock 5/16-18 | 41 | 43087 | 2 | Hex Bolt, 3/8-16 x 1-1/4" |
| 12 | 48373 | 28 | Pop Rivet | 42 | 47598 | 4 | Nut, Hex Flanged Lock 1/4" |
| 13 | 28354OR1 | 1 | Chute, Chipper Bottom | 43 | 46938 | 4 | Hex Bolt, 3/8-16 x 3-1/4" |
| 14 | 28096 | 1 | Engine | 44 | 43081 | 14 | Washer, 3/8" |
| 15 | 67974OR1 | 1 | Chute Assembly | 45 | 43830 | 1 | Adapter, Deck |
| 16 | 49974BL3 | 1 | Hose Hanger Rod | 46 | 23560BL1 | 1 | Bracket, Deck Adapter |
| 17 | 46420 | 1 | Elbow | 47 | 43080 | 2 | Bolt, Carr. 5/16" x 3/4" |
| 18 | 2-17 | 1 | Hose (6" x 126") | 48 | 23825 | 1 | Mounting Strap |
| 19 | 43793 | 2 | Hose Clamp 6" | 49 | 23826 | 1 | Angle Bracket |
| 20 | 24678BL3 | 2 | Side Panel Cart Extension | 50 | | 1 | Impeller Housing Assembly (See page 20) |
| 21 | 24679BL3 | 1 | Front Panel Cart Extension | 51 | 62468 | 1 | Deck Adapter Kit (includes all parts in box on page 18) |
| 22 | 23836BL1 | 1 | Cross Brace | 52 | 70255PH | 1 | Chipper Chute Assembly, (includes items 13, 53, 54, 55, and 56) |
| 23 | 64244 | 1 | Hard Top Assembly (Includes 24,25,26,27) | 53 | 28356 | 1 | Deflector |
| 24 | 42189 | 4 | Rivet, 3/16" | 54 | 28355BL3 | 2 | Angle, Deflector Anchor |
| 25 | 43910 | 2 | Washer, Flat 3/16" | 55 | HA24433 | 14 | Pop Rivet, 3/16" |
| 26 | 24798BL1 | 4 | Boot Mounting Strap | 56 | 68812OR1 | 1 | Ass'y, Upper Chute Welded |
| 27 | 48133 | 1 | Vinyl Boot (Hardtop) | | 3-113 | 1 | Owner's Manual |
| 28 | 44790 | 1 | Poly Rear Door | | | | |
| 29 | 43790 | 1 | Strap, Tarp 25" | | | | |
| 30 | 44849 | 2 | "S" Hook, #32 | | | | |

REPAIR PARTS FOR MODEL 45-0578 CHIP-N-VAC IMPELLER HOUSING ASSEMBLY

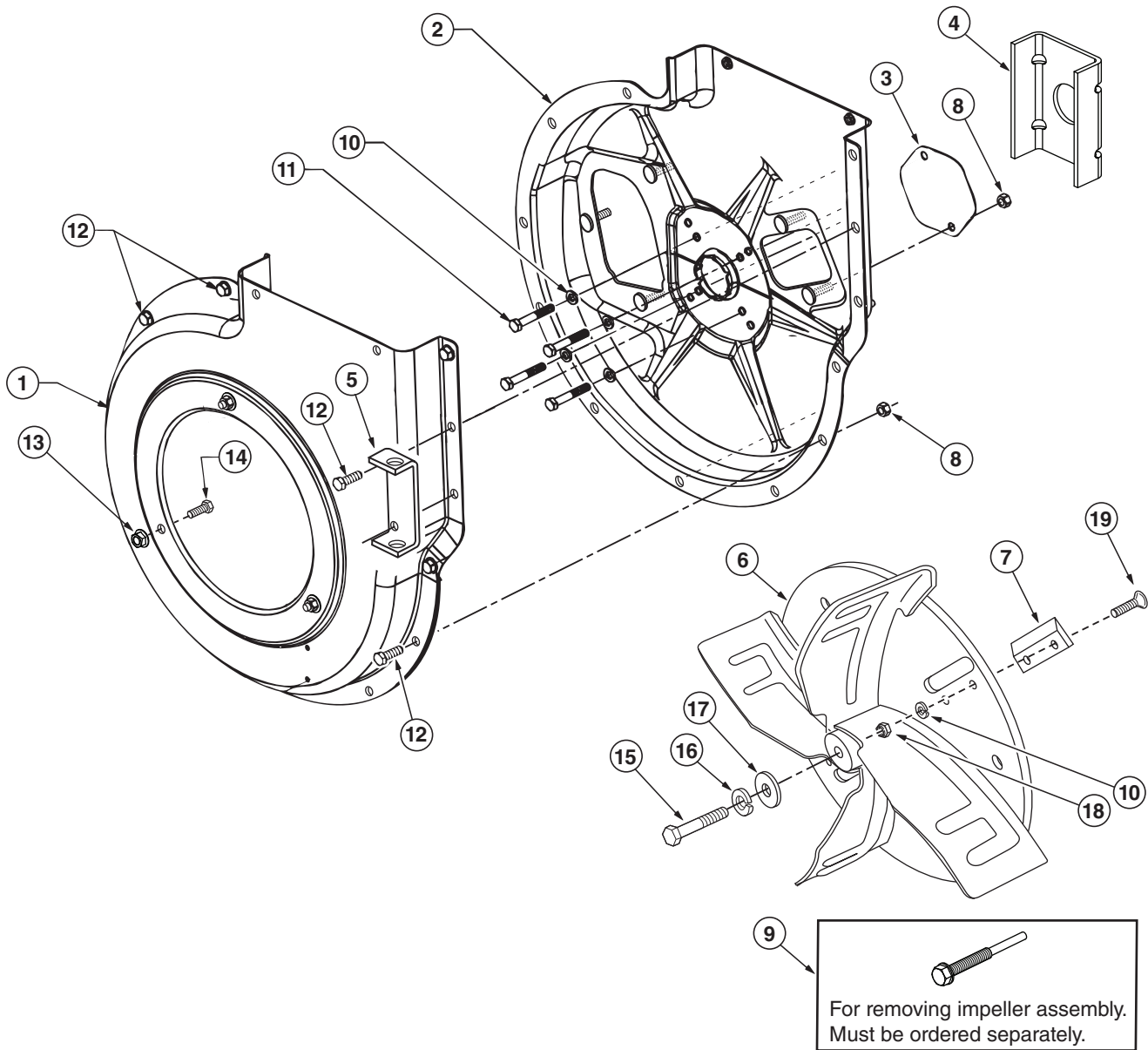

| REF. | PART NO. | QTY. | DESCRIPTION | REF. | PART NO. | QTY. | DESCRIPTION |
|------|-----------|------|--------------------------------|------|----------|------|---------------------------------|
| 1 | 24633BL3 | 1 | Housing Ass'y. Outer | 11 | 710-0772 | 4 | Bolt, Hex 5/16-24 x 2" |
| 2 | 63993BL3 | 1 | Housing Ass'y. Inner | 12 | 43182 | 12 | Bolt, Hex 5/16-18 x 3/4" |
| 3 | 27615BL1 | 1 | Cover, Chipper | 13 | 46584 | 3 | Hex Nut, Whizlock 5/16-18 Thd. |
| 4 | 27187BL1 | 1 | Spacer Bracket | 14 | 43063 | 3 | Bolt, Hex 5/16-18 x 1" |
| 5 | 24958BL1 | 1 | Hose Hanger Bracket | 15 | 710-1273 | 1 | Bolt, Hex 3/8-24 x 2-3/4" |
| 6 | 66791 | 1 | Impeller Assembly | 16 | 43003 | 1 | Lockwasher, 3/8" |
| 7 | 742-0544B | 2 | Blade, Chipper | 17 | 42828 | 1 | Flat Washer, 13/32" x 1-1/4" |
| 8 | 47810 | 14 | Nut, Hex Nylock 5/16-18 | 18 | 44738 | 4 | Nut, Hex Lock 5/16-24 "Unitork" |
| 9 | 42294 | 1 | Impeller Service Tool | 19 | 710-1054 | 4 | Screw, Flat Hd. 5/16-24 x 1" |
| 10 | 43086 | 8 | Washer, Lock 5/16" Spring Type | | | | |

SLOPE GUIDE

(Keep this sheet in a safe place for future reference.)

Use this guide to determine if a slope is safe for the operation of your tractor and Chip-N-Vac. Refer also to the instructions in your vehicle owners manual.

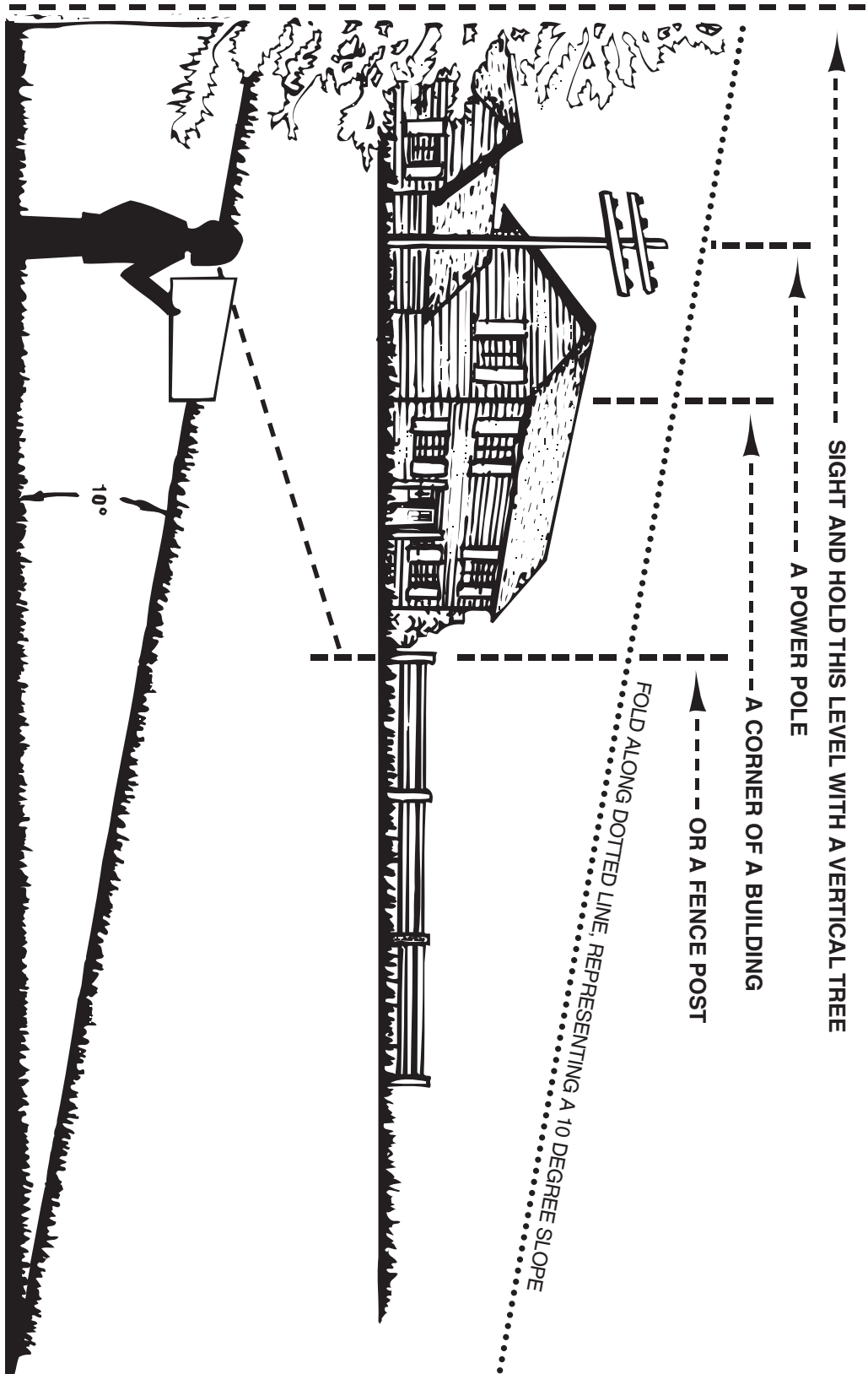

CAUTION: Do not operate your tractor and Chip-N-Vac on a slope in excess of 10 degrees. Be sure of your tractor's towing and braking capabilities before operating on a slope. Avoid any sudden turns or maneuvers while on a slope.

NOTES

NOTES

SpeedEPart *the fastest way to purchase parts* www.speedepart.com

REPAIR PARTS

809 South Hamilton
Sullivan, IL. 61951
217-728-8388
www.agri-fab.com

This document (or manual) is protected under the U.S. Copyright Laws and the copyright laws of foreign countries, pursuant to the Universal Copyright Convention and the Berne convention. No part of this document may be reproduced or transmitted in any form or by any means, electronic or mechanical, including photocopying or recording, or by any information storage or retrieval system, without the express written permission of Agri-Fab, Inc. Unauthorized uses and/or reproductions of this manual will subject such unauthorized user to civil and criminal penalties as provided by the United States Copyright Laws.