

# **Agri+Fab<sup>®</sup>**

## **Lawn Care Made Easy<sup>®</sup>**

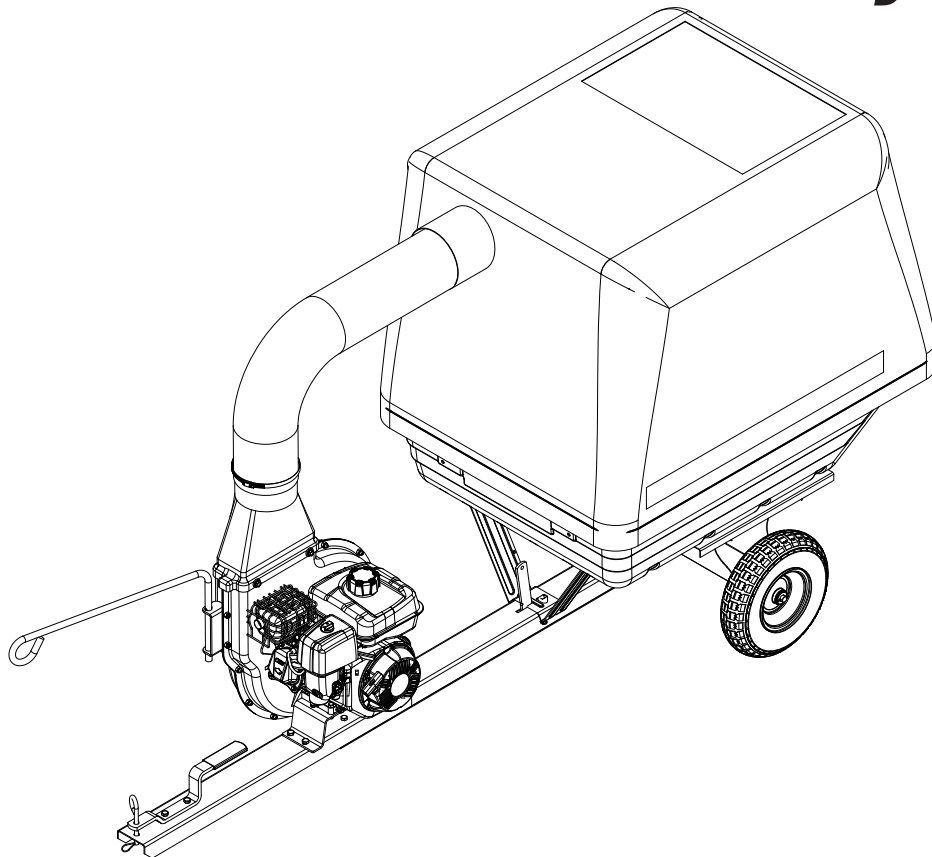

**45-05671**

### **MOW-N-VAC**

Want more information or assembly tips?



**Video  
Instruction  
Guide**

**[youtube.com/c/agrifab](https://www.youtube.com/c/agrifab)**

**IMPORTANT:** The engine is shipped without oil. Add oil before starting the engine.

**IMPORTANT:** Check engine air filter prior to each use. Follow the maintenance schedule on page 16 of this manual.

# TABLE OF CONTENTS

SAFETY .....	3,4	OPERATION.....	14,15
SAFETY LABELS .....	5	MAINTENANCE .....	16,17
FULL SIZE HARDWARE CHART (CART).....	6	STORAGE .....	17
FULL SIZE HARDWARE CHART (ADAPTER).....	6	SERVICE .....	18
CARTON CONTENTS .....	7	ROUBLESHOOTING.....	19
ASSEMBLY .....	8	REPAIR PARTS .....	20-24

## OPTIONAL ACCESSORY MODEL NO. 45-0253 12 FT. REMOTE HOSE KIT

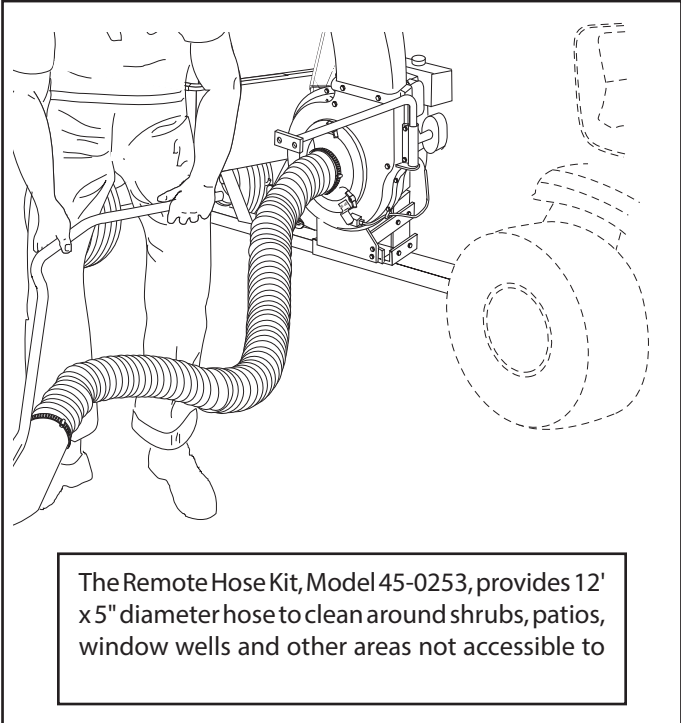



## SAFETY



Any power equipment can cause injury if operated improperly or if the user does not understand how to operate the equipment. Exercise caution at all times when using power equipment.

- Read and follow all instructions in this manual before attempting to assemble or operate this equipment. Failure to comply with these instructions may result in serious injury or death. Keep this manual in a safe place for future reference and for ordering replacement parts.
- Read this operating and service instruction manual carefully. Be thoroughly familiar with the controls and proper use of this power vacuum.
- Read the vehicle owners manual and vehicle safe operation rules before using this equipment.
- Never allow children under 16 to operate this Mow-N-Vac. Children 16 years and older should only operate under close parental supervision.
- DO NOT allow anyone to operate this equipment without proper instructions.
- DO NOT allow passengers to ride on this equipment or the towing vehicle.
- Keep the area of operation clear of others, particularly small children and pets.
- Check fuel before starting engine. Do not fill fuel tank indoors, while engine is running or while engine is hot. Wipe off any spilled fuel before starting engine.
- Engine and muffler get hot. Do not touch! To avoid fire hazard, keep clean of debris and other accumulations.
- Never store Mow-N-Vac with fuel in tank. Allow engine to cool before storing in any enclosure.
- Do not change engine governor settings.
- Do not operate engine if air cleaner or cover is removed except for adjustment. Removal of these parts could create a fire hazard.
- Keep hands, feet, face, long hair and clothing out of inlet and discharge area. There are ROTATING BLADES inside these openings.
- Before cleaning, repairing or inspecting, make certain all moving parts come to a complete stop. Disconnect spark plug wire and keep wire away from plug to prevent accidental starting. Keep throttle control lever in stop position.
- If the Mow-N-Vac should become blocked with debris at any point, shut engine off and wait until the impeller comes to a complete stop before attempting to remove the obstruction. Disconnect spark plug wire to prevent accidental starting.
- If the cutting mechanism strikes a foreign object, or if your Mow-N-Vac should start to vibrate abnormally, stop the engine immediately, disconnect spark plug wire and move the wire away from the spark plug. Allow the machine to stop and take the following steps.
  - a. Inspect for damage.
  - b. Repair or replace any damaged parts.
  - c. Check for loose parts and tighten to assure continued safe operation.
- Check all bolts for tightness at frequent intervals to help insure safe operation.
- Check top cover frequently for wear. Replace if worn or damaged.
- Never operate Mow-N-Vac unless deck adapter, hose, hose adapter (nozzle), transition snout, and top cover are properly attached in their place.
- Do not remove top cover or attempt to empty contents of cart while engine is running.
- Never attempt to change hose adapter (nozzle) or to install remote hose attachment when engine is running.
- Keep all shields, guards, and hose adapter (nozzle) in place and securely attached.
- Always wear safety glasses or other suitable eye protection when operating or maintaining this equipment.
- Do not stand behind cart in exhaust discharge area while engine is running.
- Do not operate this equipment while intoxicated or while taking drugs or medication that impairs the senses or reactions.
- When using this equipment, start the vehicle transmission in first (low) gear and then gradually increase speed only as conditions permit.
- Operate this equipment at reduced speed on rough terrain, along creeks and ditches and on slopes to prevent tipping or loss of control. Do not drive too close to a creek or ditch.
- Vehicle braking and stability are affected by the addition of this equipment. Do not fill the Mow-N-Vac to its full capacity without checking the capability of the towing vehicle to safely pull and stop with Mow-N-Vac attached.
- Before operating on any grade (hill) refer to the safety rules in the vehicle owner's manual concerning safe operation on slopes. Also refer to the SLOPE GUIDE on page 25 of this owner's manual. Do not operate on slopes in excess of 10 degrees. **STAY OFF STEEP SLOPES!**
- Follow the maintenance instructions outlined in this manual.



Look for this symbol to point out important safety precautions. It means — **Attention!! Become alert!! Your safety is involved.**



**DANGER:** This Mow-N-Vac was built to be operated according to the rules for safe operation in this manual. As with any type of power equipment, carelessness or error on the part of the operator can result in serious injury. This unit is capable of amputating fingers and hands and throwing objects. Failure to observe the safety instructions could result in serious injury or death.

# **WARNING**

## **TO AVOID SERIOUS INJURY**

- Read Owner's Manual and all safety labels on machine before starting and using machine.
- Do Not remove top cover or attempt to empty contents of cart while engine is running.
- Do Not stand behind cart in exhaust discharge area while engine is running.
- Keep hands, feet, face, long hair and clothing out of chipper inlet, vac inlet, and discharge area. There are ROTATING BLADES inside these openings.
- Wear approved safety glasses and gloves. Avoid loose fitting clothes.
- Keep the area of operation clear of all persons, particularly small children and pets.
- Keep all shields, guards and nozzle in place and securely attached.
- If unit becomes clogged or jammed, shut off engine right away. Do Not attempt to clear clog or jam with engine running.
- Muffler and engine get hot and can cause burns. Do Not Touch. To avoid a fire hazard, keep leaves, grass and other combustible debris off hot muffler and engine.
- Do Not attempt to remove or attach vac nozzle or optional Hose Kit with engine running.
- Do Not operate unit unless nozzle or optional Hose Kit is secured in place.
- Do Not fill gas tank while engine is running. Allow engine to cool at least 2 minutes before refueling.



# **DANGER**

**HAZARDOUS ROTATING BLADES INSIDE. KEEP HANDS AWAY FROM ALL OPENINGS. DO NOT REMOVE OR ATTACH HOSE, HOSE ADAPTER, ELBOW OR OPTIONAL HOSE KIT WHEN ENGINE IS RUNNING!**



# **WARNING**

This unit is equipped with an internal combustion engine and should not be used on or near unimproved forest-covered, or grass-covered land unless the engine's exhaust system is equipped with a spark arrester meeting applicable local or state laws (if any). If a spark arrester is used, it should be maintained in effective working order by the operator.

In the State of California the above is required by law (Section 4442 of the California Public Resources Code). Other states may have similar laws. Federal laws apply on federal lands. A spark arrester muffler is available at your nearest engine authorized service center.

# SAFETY LABELS

	<p><b>! DANGER</b></p> <p>Rotating blades can crush and cut.</p> <p>Do not operate with hose removed.</p> <p>Always turn off machine before clearing clog or jam.</p>
---	---

	<p><b>! WARNING</b></p> <p>Read and understand the owner's manual before operating this lawn vac.</p> <p>Failure to follow operating instructions could result in death or serious injury.</p>
--	--

agri-fab.com

800-448-9282

Reorder No. 3-18

 <b>WARNING</b>	 <b>¡ATENCIÓN!</b>	 <b>ATTENTION</b>
<ol style="list-style-type: none"> <li>DO NOT CARRY PASSENGERS</li> <li>DO NOT EXCEED MAXIMUM TOWING SPEED</li> <li>NOT FOR HIGHWAY USE</li> <li>DO NOT EXCEED LOAD CAPACITY</li> <li>STAY OFF STEEP SLOPES AND GRADES</li> <li>VEHICLE BRAKING AND STABILITY WILL BE AFFECTED BY HEAVY LOADS</li> <li>REFER TO MANUAL FOR FULL INSTRUCTIONS</li> </ol>	<ol style="list-style-type: none"> <li>NO CARGUE PASAJEROS</li> <li>NO EXCEDA LA VELOCIDAD MÁXIMA DE REMOLQUE</li> <li>NO USE EN LA CARRETERA</li> <li>NO EXCEDA LA CAPACIDAD DE CARGA DE LA CARRETILLA</li> <li>EVITE LAS SUBIDAS Y BAJADAS EMPINADAS</li> <li>LA HABILIDAD DE FRENAR Y LA ESTABILIDAD SERÁN AFECTADAS CON CARGAS MAYORES</li> <li>VEA EL MANUAL PARA LAS INSTRUCCIONES COMPLETAS</li> </ol>	<ol style="list-style-type: none"> <li>NE PAS TRANSPORTER DE PASSAGERS</li> <li>NE PAS DÉPASSER LA VITESSE MAXIMALE DU REMORQUAGE</li> <li>NE PAS UTILISER L'AUTOROUTE</li> <li>NE PAS DÉPASSER LA CAPACITÉ DE CHARGE</li> <li>GARDER LES PISTES ET LES GRADES</li> <li>LE FREINAGE ET LA STABILITÉ DU VEHICULE SERONT TOUCHÉS PAR DES CHARGES LOURDES</li> <li>CONSULTEZ LE MANUEL POUR DES INSTRUCTIONS COMPLETES</li> </ol>
   <p>46991</p>		

	<p><b>! WARNING</b></p> <p><b>HOT SURFACE</b></p>
---	---

M117554

## FULL SIZE HARDWARE CHART (CART)

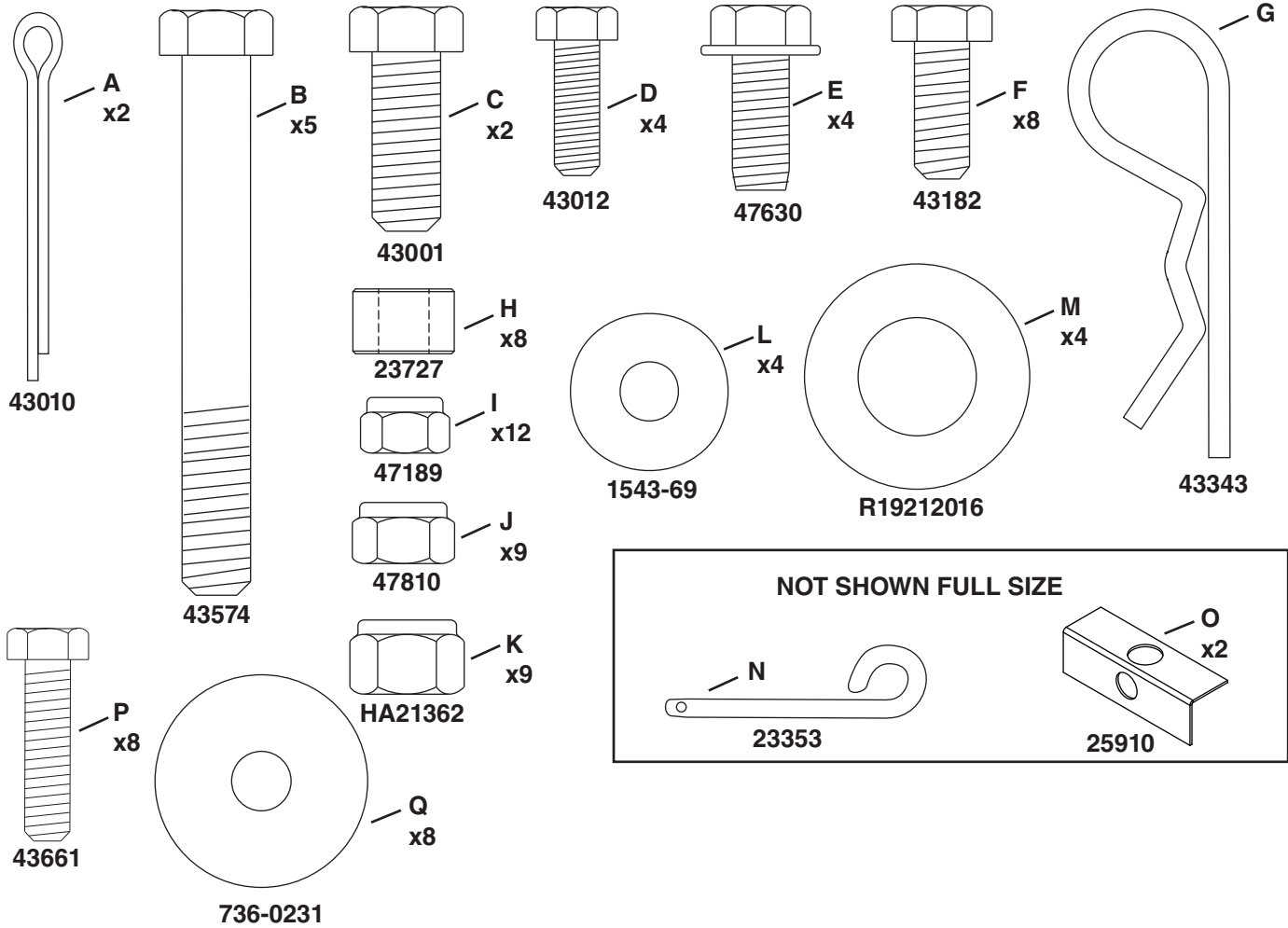

## FULL SIZE HARDWARE CHART (ADAPTER)

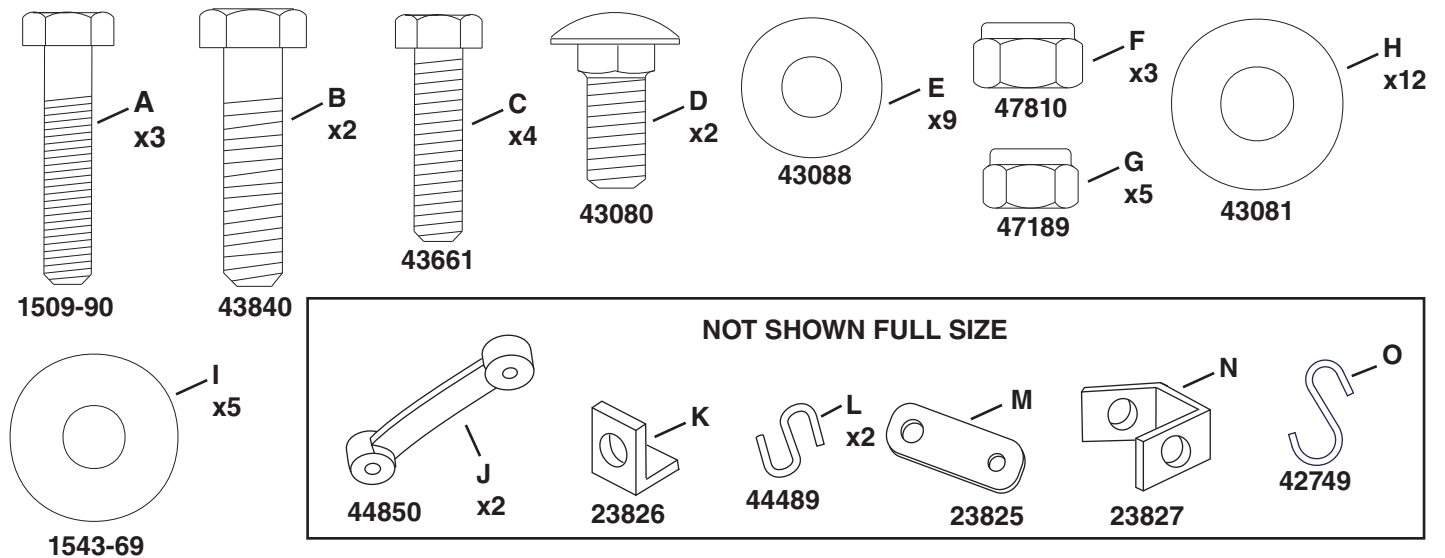

# CARTON CONTENTS

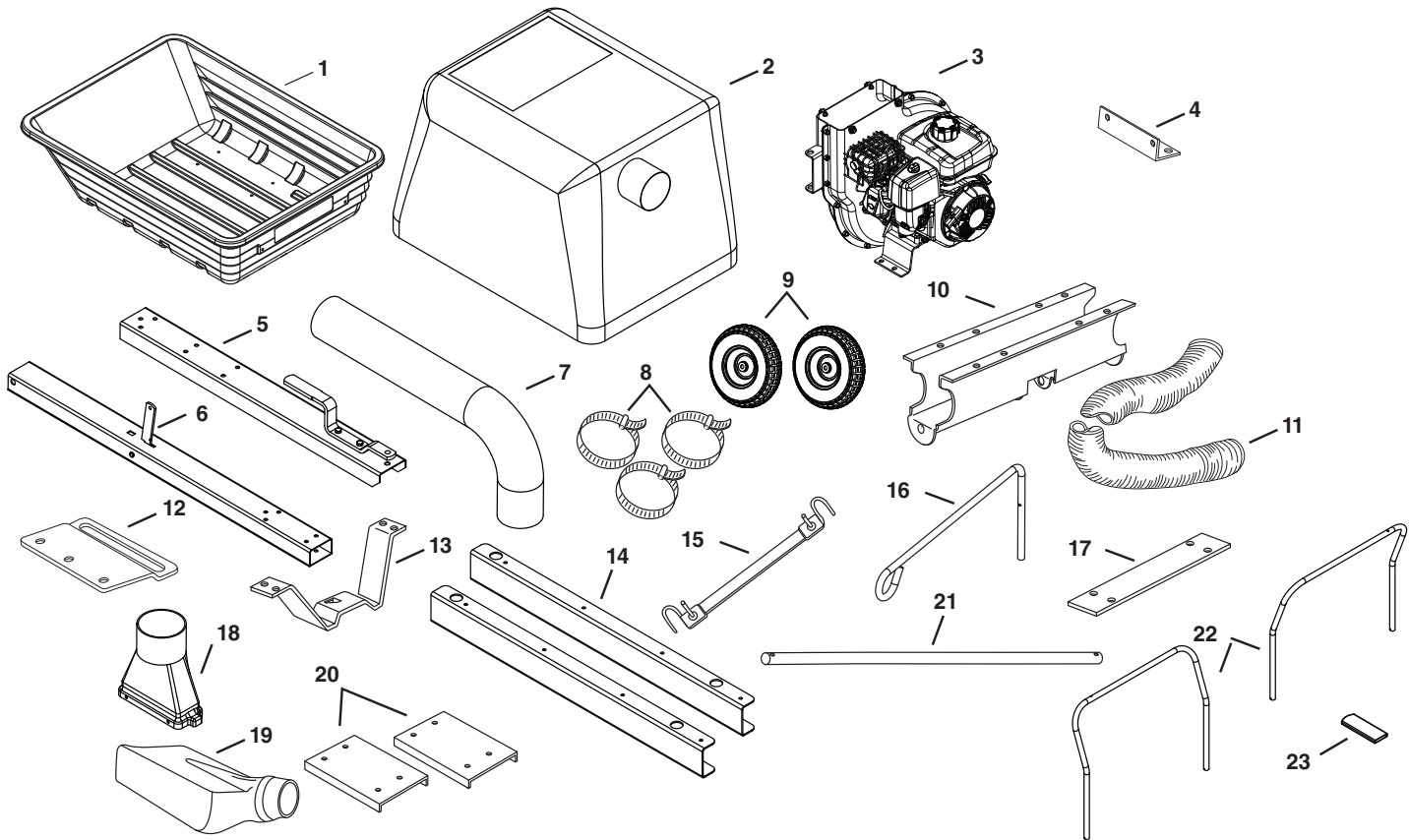

REF. NO.	PART NO.	QTY.	DESCRIPTION	REF. NO.	PART NO.	QTY.	DESCRIPTION
1	2-16	1	Cart Tray	13	24497BL1	1	Latch Stand Bracket
2	45902	1	Cart Cover	14	45900BL3	2	Lower Support Rod
3	-	1	Engine/Housing Assembly	15	43790	1	Tarp Strap, 25"
4	27304BL1	1	Attachment Bracket (Deck)	16	49974BL3	1	Hose Hanger Rod
5	-	1	Front Tongue Assembly	17	24386BL1	1	Latch Stand Plate
6	-	1	Rear Tongue Assembly	18	45916	1	Transition Snout
7	2-18	1	Hose (short)	19	43830	1	Deck Adapter
8	43793	3	Hose Clamp	20	25875BL3	2	Cart Bed Brace
9	40880G	2	Wheel	21	24908	1	Axle
10	24527BL3	1	Wheel Support	22	45901BL3	2	Support Tube
11	2-17	1	Hose (long)	23	47707	1	Handle Grip
12	23560BL1	1	Deck Adapter Bracket				

# ASSEMBLY

**NOTE:** This unit is shipped **WITHOUT GASOLINE or OIL**. After assembly, see separate engine manual for proper fuel and engine oil recommendations.

## TOOLS REQUIRED FOR ASSEMBLY

- (1) Screwdriver
- (1) Pliers
- (2) 7/16" Wrenches
- (2) 1/2" Wrench
- (2) 9/16" Wrenches
- (2) 3/4" Wrenches

## REMOVAL OF PARTS FROM CARTONS

- Remove the hardware packs and all loose parts from the cartons.
- Lay out and identify parts shown in carton contents.
- Lay out and identify parts in the hardware packs. Keep contents of each hardware package separate.

## CART ASSEMBLY

- Assemble the front tongue on top of the rear tongue using three 3/8" x 3" hex bolts (B) and 3/8" nylock nuts (K). See figure 1.
- Install the hitch pin (N) and the hair cotter pin (G) in the hitch bracket and front tongue. Slide the handle grip (23) over the handle. See figure 1.

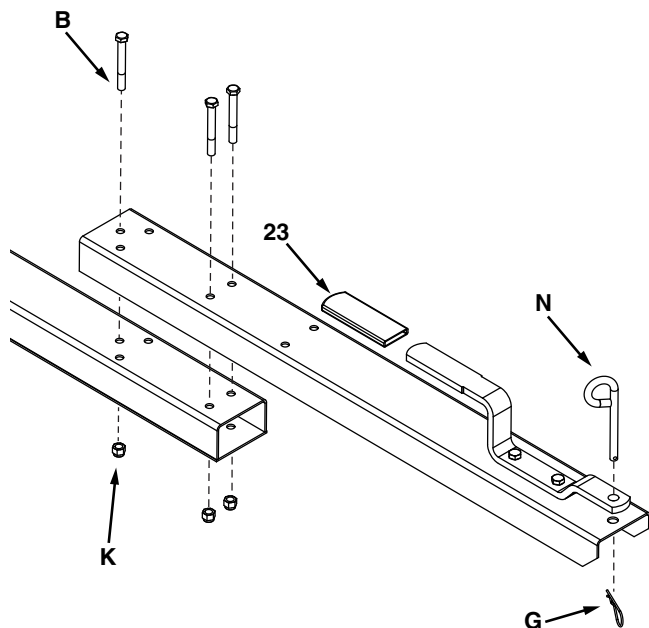

FIGURE 1

- Assemble the rear tongue (6) to the wheel support by sliding the axle (21) through the holes in the tongue and wheel support as shown in figure 2.

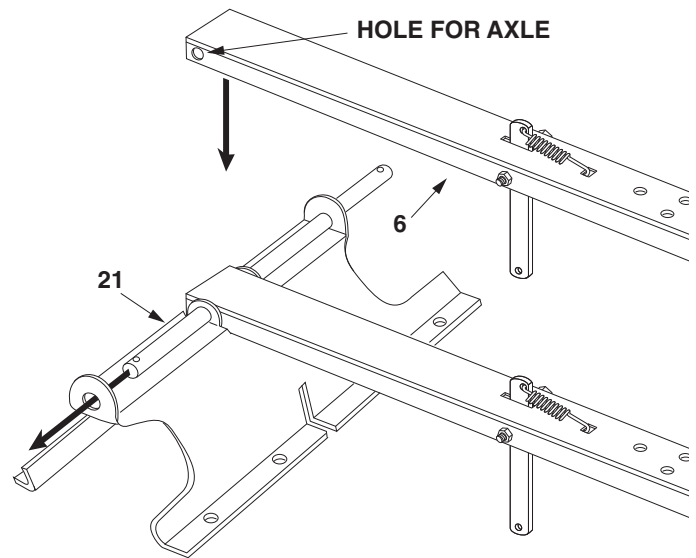

FIGURE 2



- Assemble an axle clip (O), a wheel (9) and a 5/8" washer (M) onto each end of the axle. Assemble a second 5/8" washer onto each end of the axle if space allows. Secure both wheels in place using two cotter pins (A) and bending the ends. See figure 3.

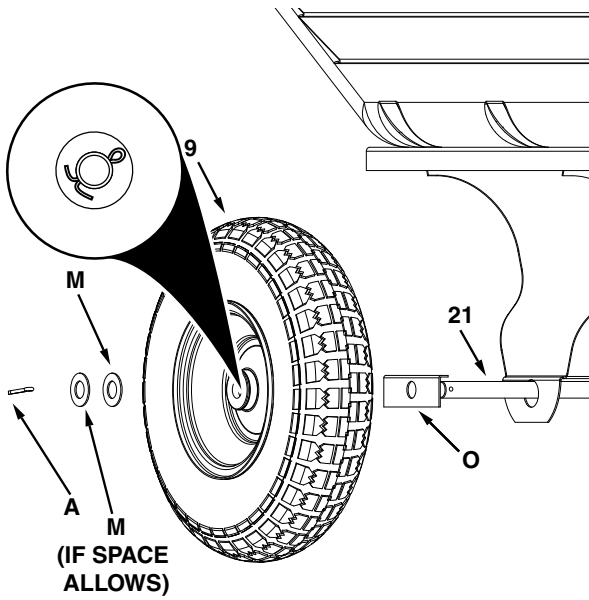

FIGURE 3

- Assemble the latch stand plate (17) and latch stand bracket (13) **WITH ALIGNMENT TAB TOWARD REAR OF CART** to the cart tray using four 1/4" x 3/4" hex bolts (D) and 1/4" nylock nuts (I). Tighten nuts after all bolts are in place. **DO NOT OVERTIGHTEN.** See figure 4.

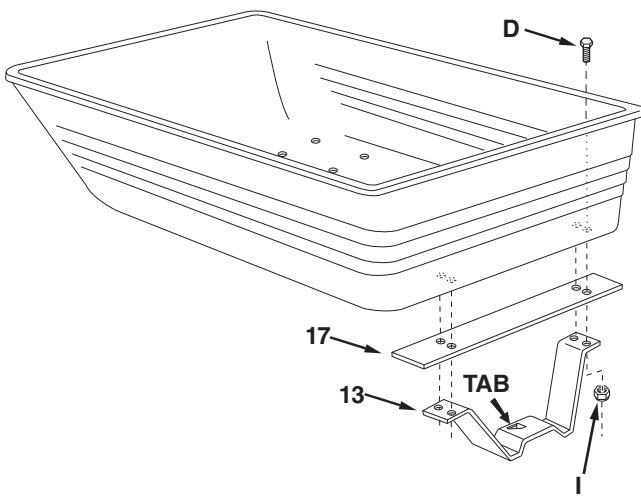

FIGURE 4

- Place the cart bed braces (20) and the cart tray onto the wheel support. Secure latch stand bracket underneath the tongue's latch lock lever. See figure 5.
- Assemble the cart tray and cart bed braces to the wheel support using eight 5/16" x 3/4" hex bolts (F) and 5/16" nylock nuts (J). Tighten nuts after all bolts are in place. **DO NOT OVERTIGHTEN.** See figure 5.

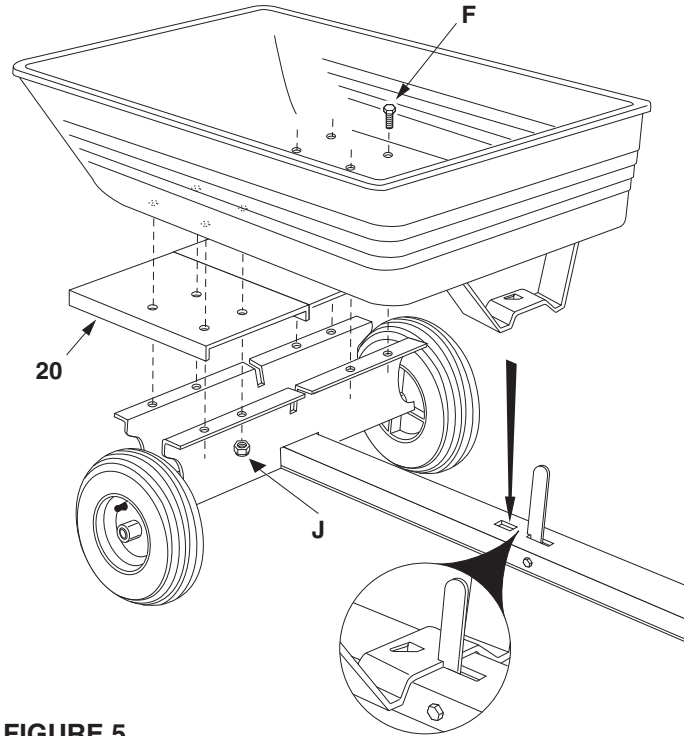

FIGURE 5

- Attach the engine mounting plate to the tongues using two 3/8" x 3" hex bolts (B) in the back holes, two 3/8" x 1" hex bolts (C) in the front holes and four 3/8" nylock nuts (K). See figure 6. Note: Engine shown may be different from your unit.

**HINT:** For easier assembly, support the rear tongue with a block of wood.

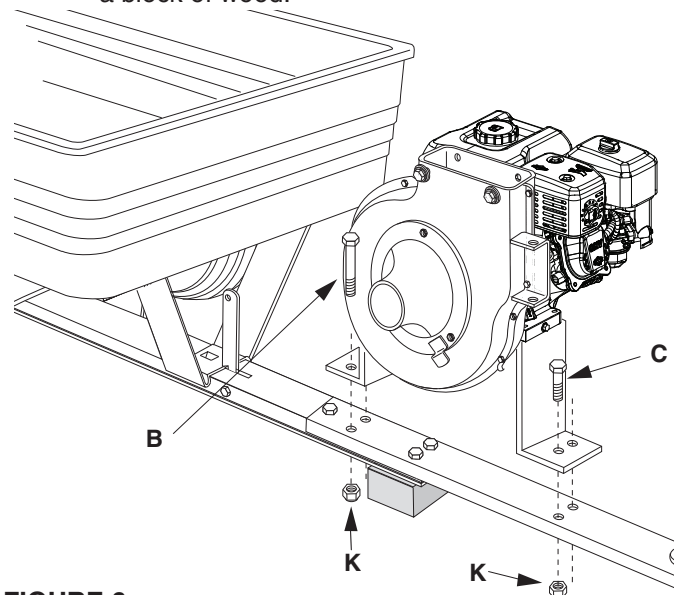
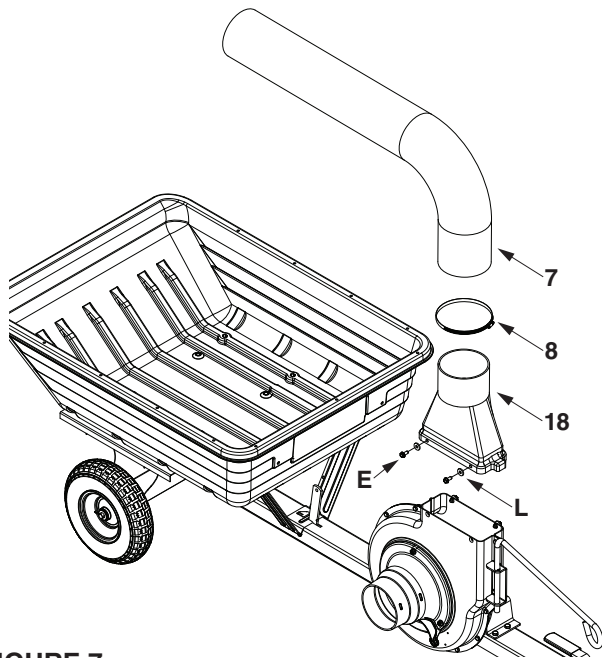

FIGURE 6

- Attach the transition snout (18) to the top of the engine housing using four 5/16" x 3/4" hex bolts (E) and nylon washers (L). Attach the short hose (7) to the transition snout using a hose clamp (8) See figure 7. Note: Engine not shown for clarity.

**HINT:** Push in on hex bolts as you tighten to form threads.



**FIGURE 7**

- Place the hose hanger rod (16) down into the hose hanger bracket on the impeller housing assembly. See figure 8.

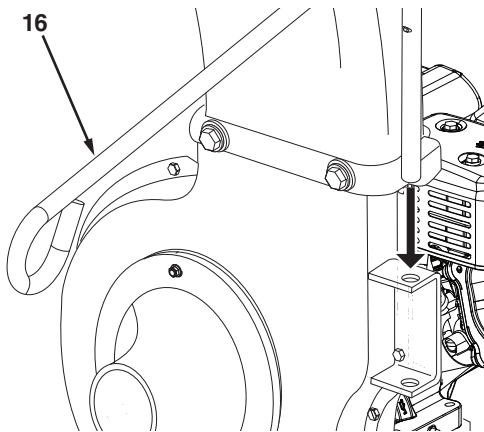

**FIGURE 8**

- Place a hose clamp (8) onto the end of the hose (11). Push the hose onto the hose adapter (nozzle). Tighten the hose clamp onto the hose and hose adapter. Do not collapse the hose adapter when tightening the clamp. See figure 9.
- The remaining hose clamp will be used later to fasten the hose to the deck adapter.

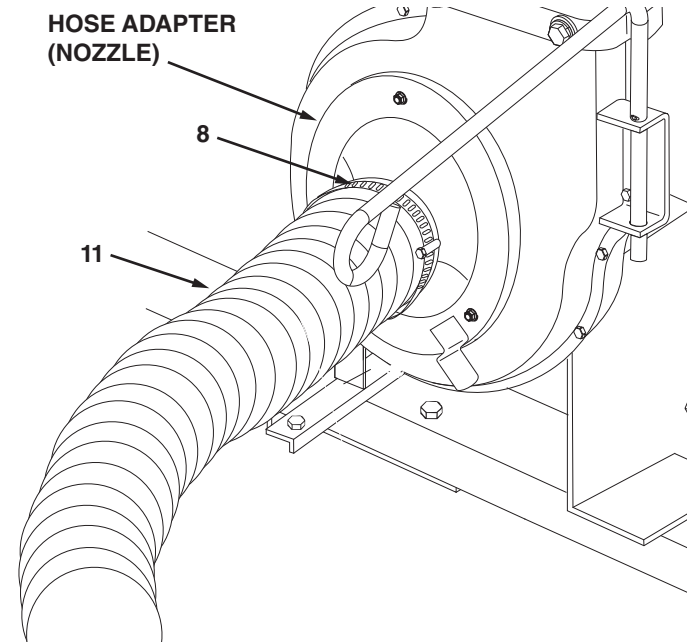

**FIGURE 9**

- Loop the 25" tarp strap (15) under the hose. Fasten the hooks to the hose hanger rod (16). See figure 10.

## CART COVER ASSEMBLY

- Insert four 1/4" x 1" bolts (P) upwards through the holes in the side of the cart bed. Slide on a washer (Q) and spacer (H) onto each bolt. Attach a side rail (14) with the opening towards the inside of the cart, small hole towards the front and larger hole towards the back and secure with a 1/4" nylock nut (I). Repeat for the other side. See figure 11.

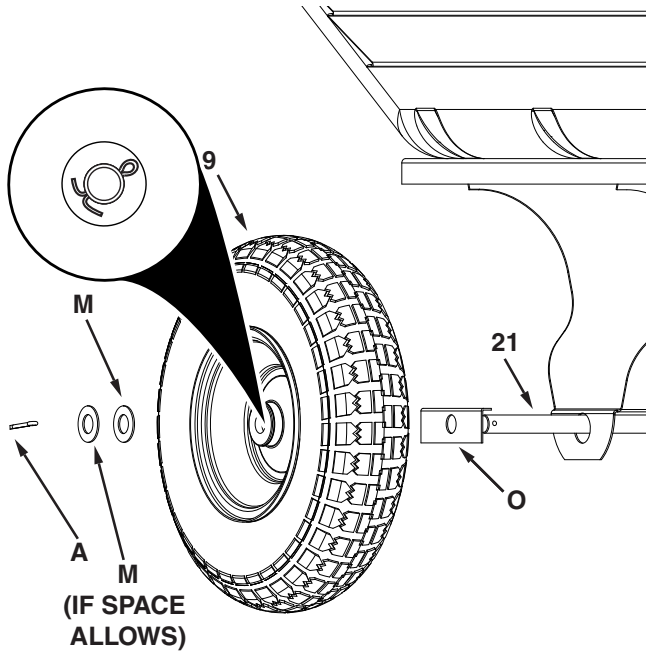

FIGURE 11

- Insert support tubes (22) into both upper and lower holes in the side rails. Make sure the support tubes are positioned as shown below. See Figure 12.

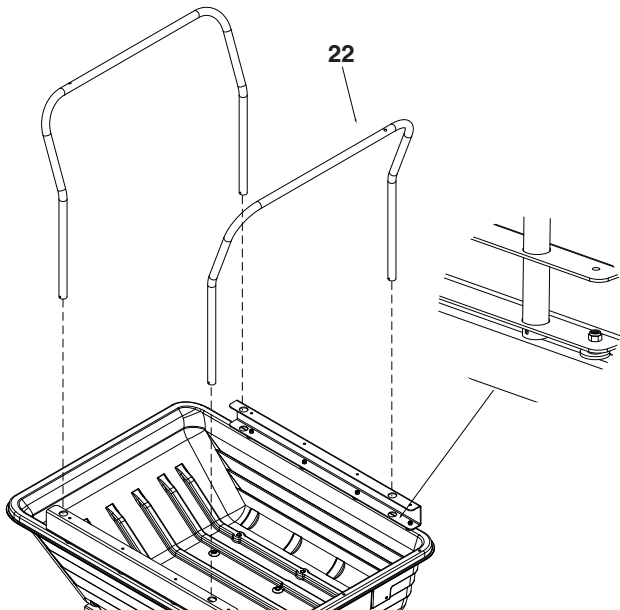

FIGURE 12

- Slide the cover (2) over the side rails. Make sure the hole for the hose is facing the front of the cart.

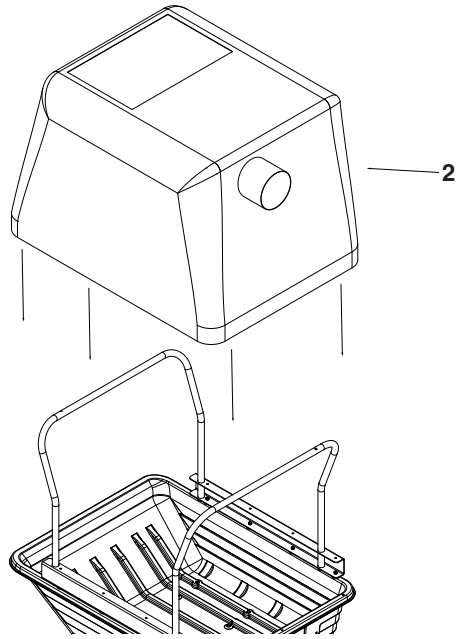

FIGURE 13

- Insert the hose through the hole in the cover and secure with the drawstring lock. See figure 14.

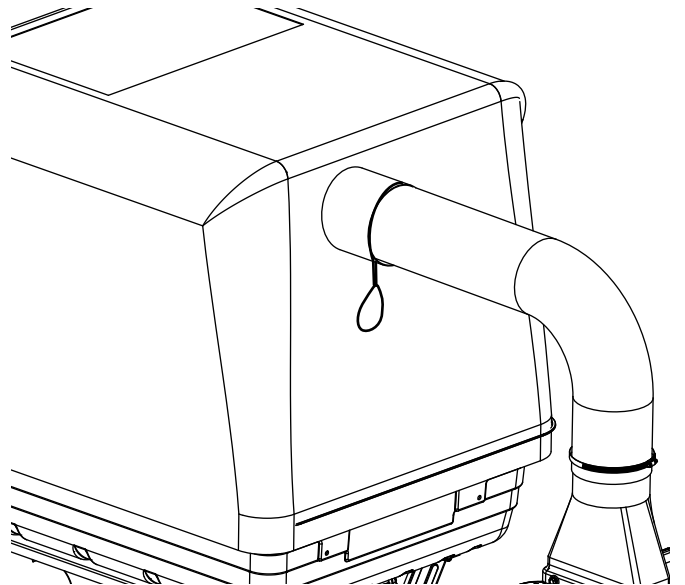

FIGURE 14

## ASSEMBLING THE DECK ADAPTER TO THE MOWER DECK

**NOTE:** Not all of the parts in the deck adapter hardware package will be needed for your particular fit up.

- Remove the mower discharge deflector from your mower deck. Save the deflector and hardware for remounting deflector.



**WARNING:** Mower deflector must be replaced when Mow-N-Vac deck adapter is removed. Do Not operate mower unless adapter or deflector is in place and properly mounted.

- Identify and cut out the template for your **brand and size** mower deck. If there is no template included for your deck size, you can make your own template by marking around a piece of cardboard held against the edge of the deck's discharge opening.
- Tape the template to the face of the adapter, about 1/2" from front and 1/4" down from top for deeper decks. For shallow decks, position template low enough that adapter will not extend below bottom of deck. Mark outline of template on face of adapter using white crayon, nail or scribe. Drill a starting hole inside the outline, then use a saber saw or key hole saw to cut out the opening. See figure 15.

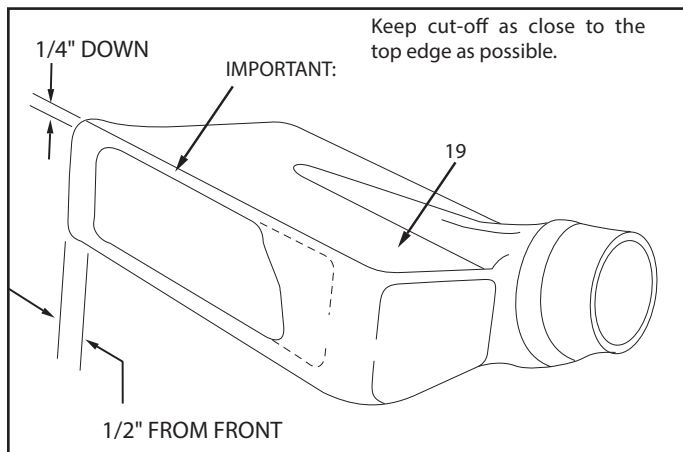

**FIGURE 15**

- Position the adapter (19) over the deck opening, and check for fit of cutout as shown in figure 16. Trim cutout, if necessary, to allow tilting of adapter, keeping the fit as close as possible for best vacuum suction.

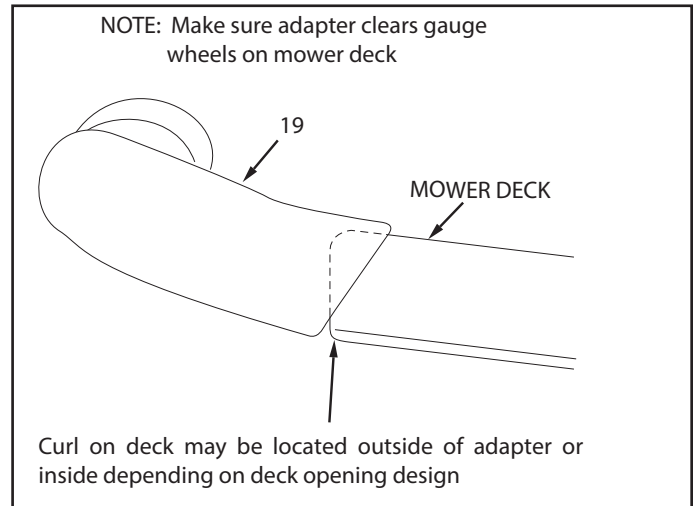

**FIGURE 16**

- Holding the adapter bracket (12) and the deck adapter together, position the deck adapter on the mower deck. Keeping the edge of deck adapter as close as possible to the offset in the adapter bracket, see if the slot in the adapter bracket can be aligned with one or two of the deflector holes in your mower deck's discharge opening. If the bracket can not be located correctly using existing holes, it will be necessary to drill one or two 5/16" diameter holes in the deck. See figure 17.

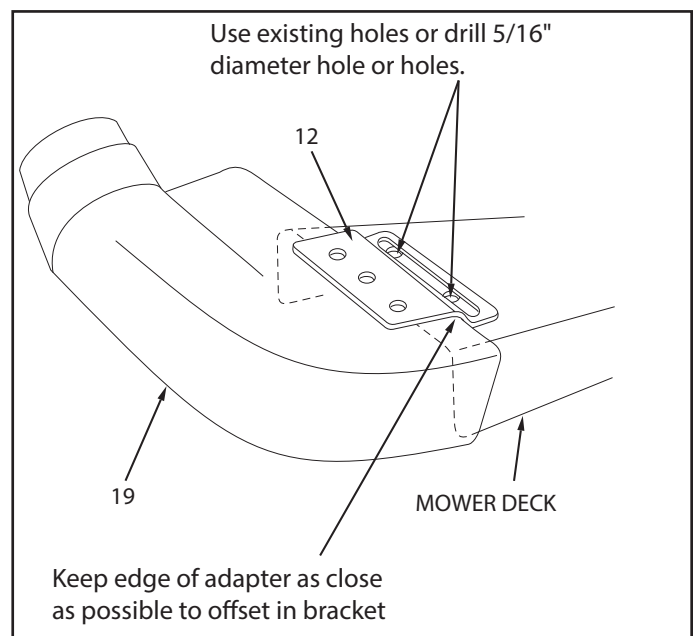

**FIGURE 17**

- Assemble the adapter bracket to the deck using two 5/16" x 1-1/4" hex bolts, (B) 5/16" flat washers (H) and 5/16" nylock nuts (F). See figure 18.

**NOTE:** It may be necessary to use extra 5/16" flat washers to shim under the bracket next to the deck surface. Ten extra washers have been furnished as shims. See figure 18.

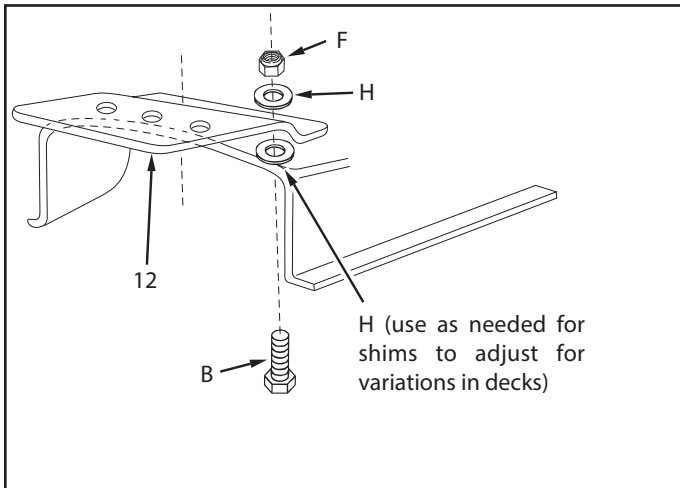

**FIGURE 18**

- With deck adapter positioned correctly over the discharge opening, use the adapter bracket as a template and drill three 9/32" diameter holes in the top of the deck adapter. See figure 19.
- Bolt deck adapter to bracket using three 1/4" x 1" bolts (C), nylon washers (I), 1/4" flat washers (E) and 1/4" nylock nuts (G). Nylon washers should be against the inside of the deck adapter. See figure 19.

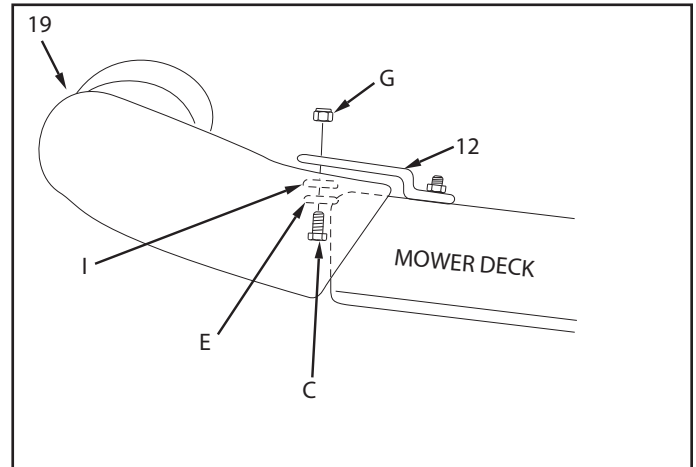

**FIGURE 19**

- Assemble end of hose and a hose clamp over the round opening of deck adapter and tighten clamp.
- **GO DIRECTLY TO THE OPERATION INSTRUCTIONS ON PAGE 14.**

# OPERATION

## KNOW YOUR MOW-N-VAC

Read this owner's manual and safety rules before operating your Mow-N-Vac.

Compare the illustration below with your Mow-N-Vac to familiarize yourself with the various controls and their locations.

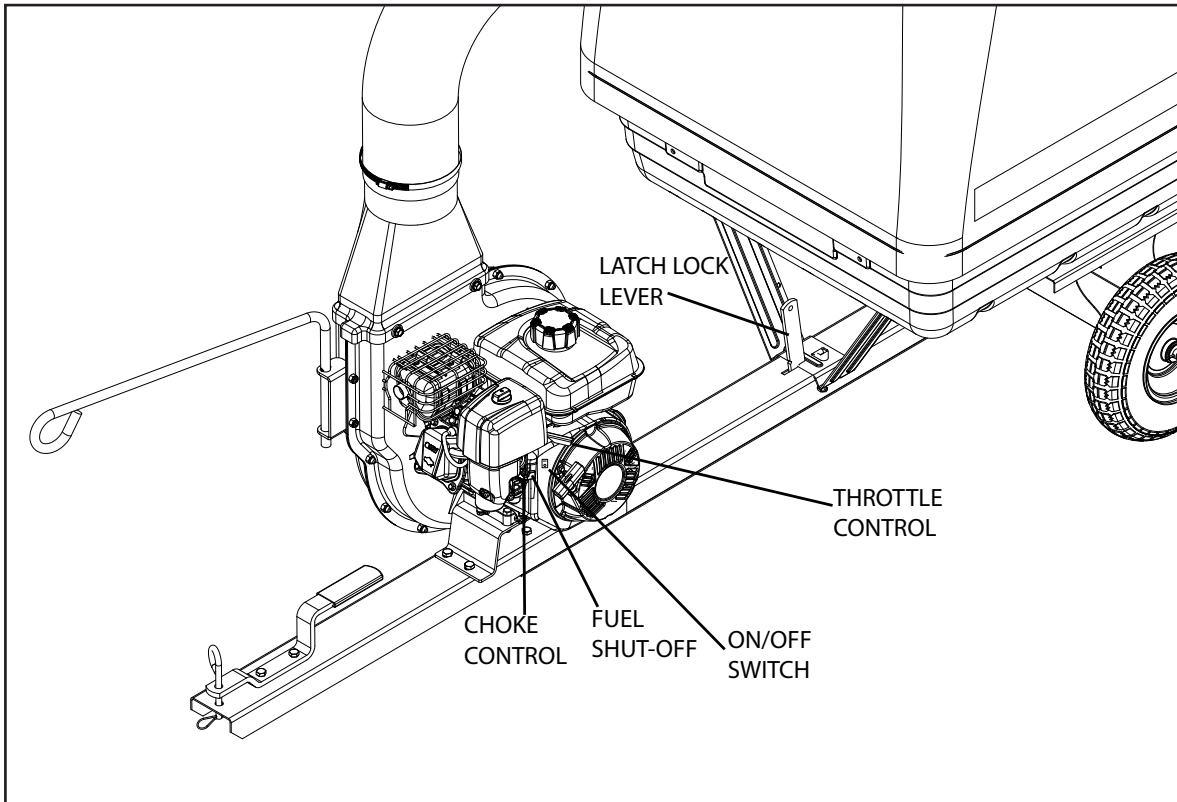

**THROTTLE CONTROL** Controls speed of engine.

**CHOKE CONTROL** Adjust to allow cold starting.

**FUEL SHUT-OFF** Shuts off fuel flow to engine.

**ON-OFF SWITCH** Turns on and off engine ignition.

**LATCH LOCK LEVER** Locks the cart bed down to the tongue. Releases to allow cart to be tipped back for dumping.



**CAUTION:** Alcohol blended fuels (called gasohol or using ethanol or methanol) can attract moisture which leads to separation and formation of acids during storage. Acidic gas can damage the fuel system of an engine while in storage. To avoid engine problems, the fuel system should be emptied before storage for 30 days or longer. Drain the gas tank, start the engine and let it run until the fuel lines and carburetor are empty. Use fresh fuel next season.

See STORAGE Instructions on page 17 for additional information.

Never use engine or carburetor cleaner products in the fuel tank or permanent damage may occur.



**WARNING:** Never fill fuel tank indoors, or with the engine running, or while the engine is hot. Do not smoke while filling tank.

## BEFORE STARTING

**FILL THE ENGINE WITH OIL!** Your engine is shipped without oil or gasoline. Add oil as instructed in Engine Maintenance on page 17 of this manual. Add gas as instructed in the separate engine manual.

- Inspect the Mow-N-Vac to make sure all parts including the deck adapter are properly attached.
- Check tires for proper inflation.

## HOW TO STOP YOUR MOW-N-VAC

- To stop engine, move the throttle control lever to the SLOW position.
- Push On/Off switch to OFF
- Disconnect spark plug wire from plug to prevent accidental starting while equipment is unattended or is being worked on.



**CAUTION:** The muffler and adjacent areas are hot!

## HOW TO START YOUR MOW-N-VAC



**WARNING:** Never start or run the engine without all covers being properly attached to the blower housing and cart.

- Check oil and gas in Mow-N-Vac engine.
- Attach spark plug wire to spark plug.
- Push On/Off switch to ON
- Move choke lever on engine to CHOKE position. (A warm engine may not require choking.)
- Move throttle control lever on engine to FAST position.
- Grasp starter handle and pull rope out slowly until engine reaches start of compression cycle (rope will pull slightly harder at this point). Let the rope rewind slowly.
- Pull rope with a rapid, continuous, full arm stroke. Keep a firm grip on starter handle. Let rope rewind slowly. Do not let starter handle snap back against starter.
- Repeat instructions in two preceding paragraphs until engine fires. When engine starts, move choke control gradually to RUN position.

## HOW TO USE YOUR MOW-N-VAC



**CAUTION:** Vehicle braking and stability may be affected with the addition of an accessory or an attachment. Be aware of changing conditions on slopes.

- Inspect the Mow-N-Vac to make sure the cover, transition snout, hoses, and deck adapter are properly attached.
- Check tires for proper inflation.
- Check for oil and gas in Mow-N-Vac engine.
- Begin operation at low speed, adjusting forward speed to match grass height and/or moisture condition to prevent clogging.
- Do not attempt to vacuum up any material other than vegetation found in a normal yard, such as light branches, leaves, twigs, etc.



**WARNING:** Should your Mow-N-Vac become clogged, shut off tractor and Mow-N-Vac engines. Before attempting to unclog, remove wire from spark plug to prevent accidental starting.

---

## TO EMPTY THE CART

- Shut off the tractor engine and set the brake.
- Shut off the Vac engine.
- Loosen draw string lock and pull the hose out of the cover.
- Secure cover in upright position.
- Release latch lock lever on tongue and tip cart back.
- Using a rake or suitable tool, pull grass clippings and/or leaves out of the cart.

- After the cart is emptied, tip it forward and secure it to the tongue with the latch lock lever. Fold down cover and secure in place with the rope.



**CAUTION:** To avoid possible injury, be sure that no one is near the cart before releasing the latch lock lever.

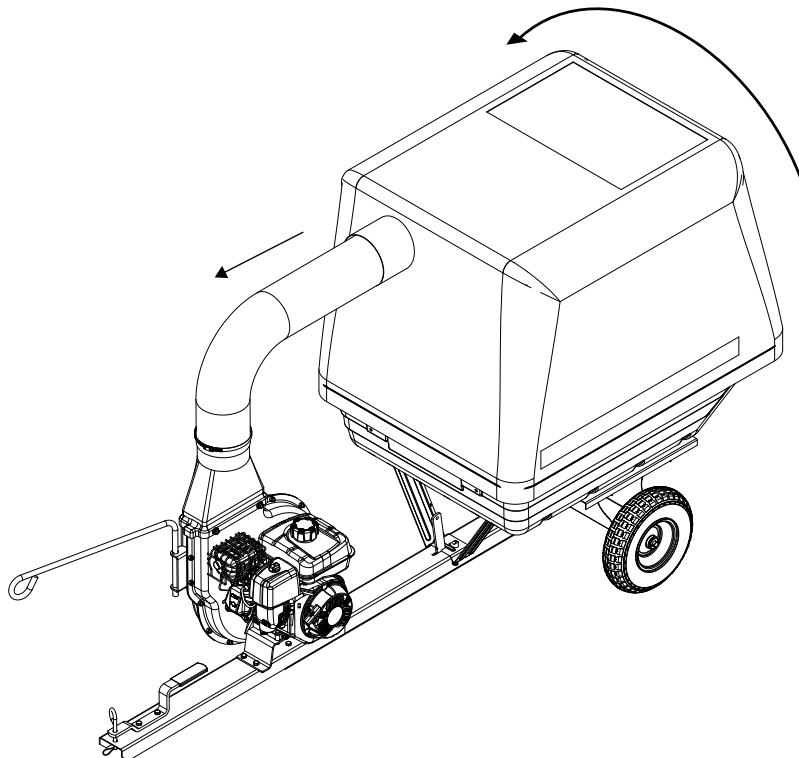

# MAINTENANCE

## CUSTOMER RESPONSIBILITIES

- Read and follow the maintenance schedule and the maintenance procedures listed in this section.

MAINTENANCE SCHEDULE Fill in dates as you complete regular service.								Service Dates							
	Before each use	After each use	Before storage	First 5 to 8 hrs.	25 hrs. or every season	50 hrs. or every season	100 hrs. or every season								
Check engine oil level	X														
Check tire pressure	X														
Check soft vinyl boot	X														
Check for loose fasteners	X														
Clean		X	X												
Change engine oil				X		X*									
Check air filter pre-cleaner	X														
Check air filter cartridge	X														
Service air filter pre-cleaner					X**										
Service air filter cartridge					X**										
Replace spark plug							X								
Lubricate					X										
Maintain engine per instructions below and in engine manual.															

\*Change oil every 25 hours when operating the engine under heavy load or in high temperatures.

\*\*Clean more often under dusty conditions or when airborne debris is present. Replace air cleaner parts, if very dirty.

## BEFORE EACH USE

### CHECK FOR LOOSE FASTENERS

- Make a thorough visual check of the Mow-N-Vac for any bolts and nuts which may have loosened. Retighten any loose bolts and nuts.



**WARNING:** Always stop engine and disconnect spark plug wire before cleaning, lubricating or before performing any repairs or maintenance.

### CHECK COVER

- Check the cover for wear. Replace cover if worn or damaged.

### CHECK TIRE PRESSURE

- Check tire pressure regularly. Do not exceed the maximum pressure listed on the side of the tire.

### CHECK ENGINE OIL LEVEL

- Check oil level before each use. Maintain engine oil as instructed in the separate engine manual.

### CHECK AIR FILTER

- Check air filter before each use. Clean if dirt is present. Refer to instructions on page 18.

## LUBRICATION

- At the beginning of each season, lubricate the latch, latch pivot bolt, and the axle where the hitch tongue pivots, with a light machine oil.

## CLEANING

- Make sure the cart and top are cleaned after each use. Grass clippings and leaves left in the cart will mildew and cause damage if not cleaned out.
- Clean the engine** regularly with a cloth or brush. Keep the cooling fins on the engine housing clean to permit proper air circulation which is essential to engine performance and life. Be sure to remove all dirt and debris from muffler area.



## ENGINE MAINTENANCE

Always use STA-BIL® 360 Performance in every tank to prevent ethanol related fuel problems. STA-BIL® is the only approved fuel stabilizer for use in Agri-Fab equipment.

Only use high quality detergent oil rated with API service classification SF or SG. Select the oil's SAE viscosity grade according to your expected operating temperature. SAE 30 grade oil is recommended for warm weather use. For cold weather use refer to the engine manufacturer's Operating and Maintenance Manual.

- Check **oil level** before each use. Maintain engine oil at level shown in figure 20 below.
- Service **air cleaner** every 25 hours under normal conditions. Clean every few hours under extremely dusty conditions. Poor engine performance and flooding usually indicates that the air cleaner should be serviced. To service the air cleaner, refer to the separate engine manual.
- The **spark plug** should be cleaned and the gap reset once a season. Spark plug replacement at the start of each season is recommended. Check the engine manual for correct plug type and gap specifications.

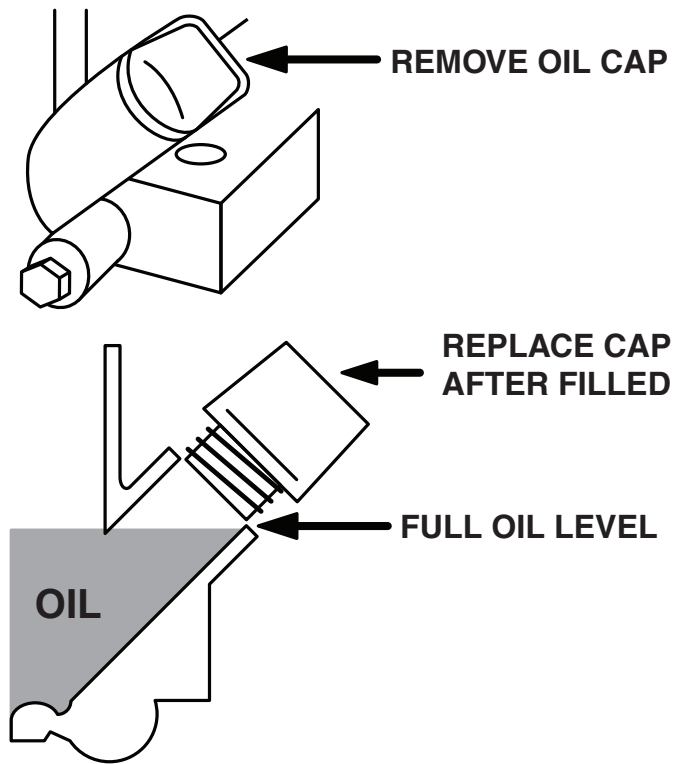

FIGURE 20

## STORAGE

It is important to prevent gum deposits from forming in essential fuel system parts such as the carburetor, fuel filter, fuel hose or tank during storage. Also, alcohol blended fuels (called gasohol or using ethanol or methanol) can attract moisture which leads to separation and formation of acids during storage. Acidic gas can damage the fuel system of an engine while in storage.

## SERVICE AIR FILTER



**WARNING:** Fuel and its vapors are extremely flammable and explosive. Fire or explosion can cause severe burns or death.

- Never start and run the engine with the air cleaner assembly or the air filter removed.
- Remove the cover B as shown in figure 21.
- To prevent debris from falling into the carburetor, carefully remove the pre-cleaner D and filter C from the air filter base F. See figure 21.
- Gently tap the filter C on a hard surface to loosen debris. If the filter is excessively dirty, replace with a new filter. See figure 21.
- Remove the pre-cleaner D from the filter C. See figure 21.
- Wash the pre-cleaner D in liquid detergent and water. Allow the pre-cleaner to thoroughly air dry. Do not oil the pre-cleaner.
- Assemble the dry pre-cleaner D to the filter C.
- Install the filter C and pre-cleaner D to air filter base F and onto stud G. Make sure filter is properly assembled to air filter base and secure with fastener E. See figure 21.
- Install the cover B and secure with fastener A. Make sure fastener is tight. See figure 21.

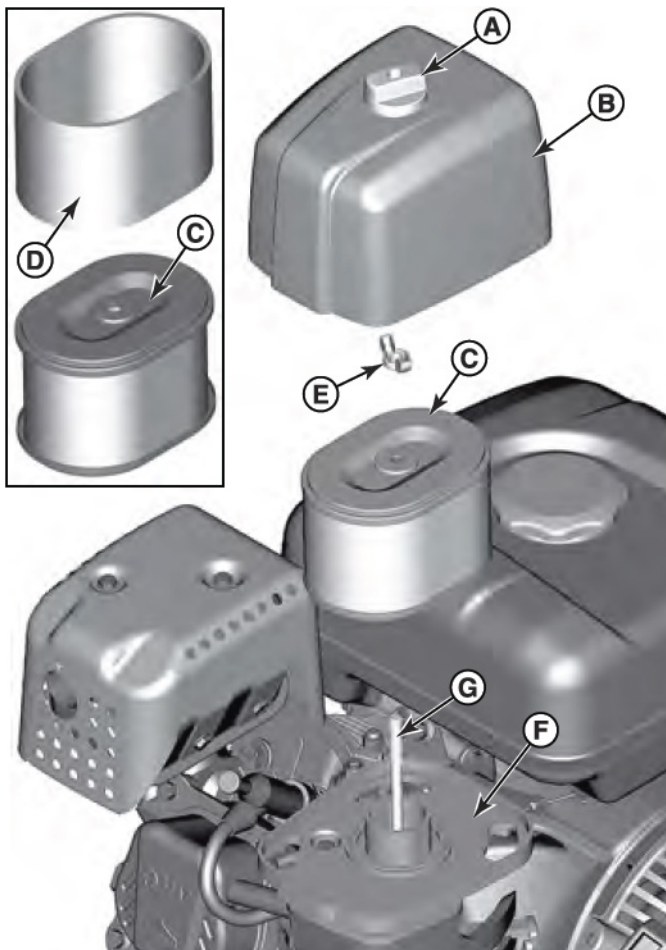

FIGURE 21



**WARNING:** Always stop the engine and remove the spark plug wire before working on the engine or the impeller housing assembly.

1. Remove the outer impeller housing assembly.
2. Remove the bolt from the impeller hub. See figure 22.
3. Screw three 3/8" x 2" full thread bolts into the three nuts welded to the impeller until they contact the housing behind the impeller. See figure 22.
4. Continue screwing in the bolts about 1/2 turn at a time in sequence until the impeller breaks free from the engine drive shaft.

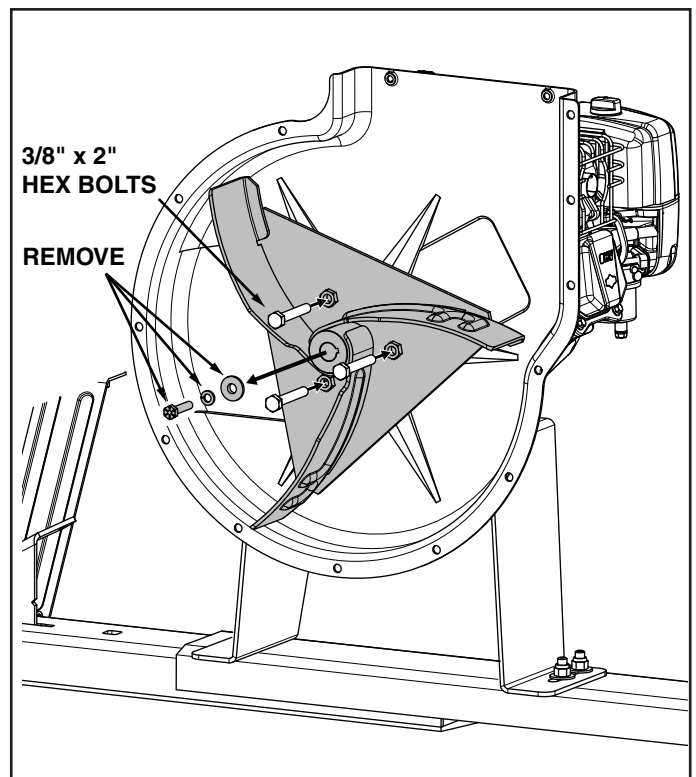

FIGURE 22

## TROUBLESHOOTING

PROBLEM	POSSIBLE CAUSE(S)	CORRECTIVE ACTION
Engine fails to start	<ol style="list-style-type: none"> <li>1. Spark plug wire disconnected.</li> <li>2. Fuel tank empty, or stale fuel.</li> <li>3. Fuel shut-off valve closed (if so equipped).</li> <li>4. Faulty spark plug.</li> </ol>	<ol style="list-style-type: none"> <li>1. Connect wire to spark plug.</li> <li>2. Fill tank with clean, fresh fuel.</li> <li>3. Open fuel shut-off valve.</li> <li>4. Clean, adjust gap or replace.</li> </ol>
Loss of power; operation erratic.	<ol style="list-style-type: none"> <li>1. Spark plug wire loose</li> <li>2. Unit running on CHOKE.</li> <li>3. Blocked fuel line or stale fuel.</li> <li>4. Water or dirt in fuel system.</li> <li>5. Carburetor out of adjustment.</li> <li>6. Dirty air cleaner.</li> </ol>	<ol style="list-style-type: none"> <li>1. Connect and tighten spark plug wire.</li> <li>2. Move choke lever to OFF position.</li> <li>3. Clean fuel line; fill tank with clean fresh gasoline.</li> <li>4. Disconnect fuel line at carburetor to drain fuel tank. Refill with fresh fuel.</li> <li>5. Adjust carburetor.*</li> <li>6. Service air cleaner.*</li> </ol>
Engine overheats	<ol style="list-style-type: none"> <li>1. Carburetor not adjusted properly.</li> <li>2. Engine oil level low.</li> </ol>	<ol style="list-style-type: none"> <li>1. Adjust carburetor.*</li> <li>2. Fill crankcase with proper oil.</li> </ol>
Too much vibration	<ol style="list-style-type: none"> <li>1. Loose parts or damaged impeller.</li> </ol>	<ol style="list-style-type: none"> <li>1. Stop engine immediately and disconnect spark plug wire. Tighten all bolts and nuts. Make all necessary repairs. If vibration continues, have unit serviced by an authorized service dealer.</li> </ol>
Unit does not discharge	<ol style="list-style-type: none"> <li>1. Hoses are clogged.</li> <li>2. Foreign object lodged in impeller.</li> <li>3. Mow-N-Vac Cart is full.</li> </ol>	<ol style="list-style-type: none"> <li>1. Stop engine immediately and disconnect spark plug wire. Clear hose(s) of debris.</li> <li>2. Stop engine immediately and disconnect spark plug wire. Remove lodged object.</li> <li>3. Empty cart.</li> </ol>

\*Refer to the engine manual packed with your unit.

**NOTE:** For repairs beyond the minor adjustments listed above, please contact your nearest authorized service dealer.

## TIPS AND TRICKS

- If the cart is too full, it will be more difficult to empty - make sure to empty the cart often.
- The long hose may slightly drag on the ground depending on your tractor. Most lawns will not damage a dragging hose, but avoid dragging the hose over gravel or pavement.
- Driving at a slower speed increases the efficiency of the vac system, especially when material is damp or wet.
- Make sure the drawstring on the cover is tight around the hose.
- Make sure the cover is tight under the lip of the cart bed.
- Make sure to take wide turns if your tractor has a tight turning radius.
- It may be helpful to loop the tarp strap holding the long hose more than once if possible.
- Make sure to clear the drawstring lock of debris often - this will help ensure the drawstring continues to function properly.
- If the short hose becomes punctured on the outside of the bend, rotate the hose so the puncture is on the inside of the bend.

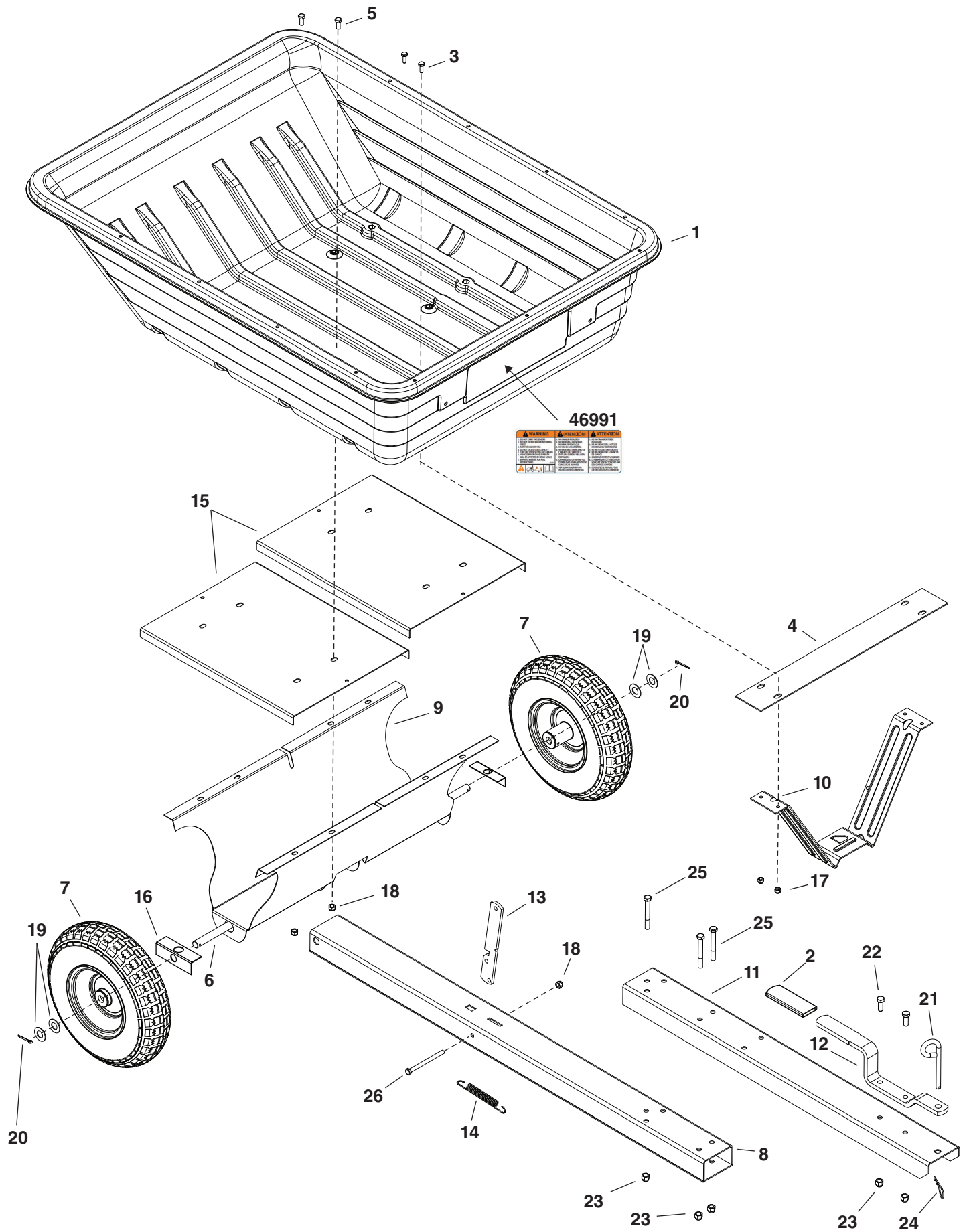

## REPAIR PARTS FOR MODEL 45-05671

REF. NO.	PART NO.	QTY.	DESCRIPTION	REF. NO.	PART NO.	QTY.	DESCRIPTION
1	2-16	1	Cart Tray	15	25875BL3	2	Cart Bed Brace
2	47707	1	Handle Grip	16	25910	2	Axle Clip
3	43012	4	Hex Bolt, 1/4-20 x 3/4"	17	47189	4	Nylock Nut, 1/4-20
4	24386BL1	1	Latch Stand Plate	18	47810	9	Nylock Nut, 5/16-18
5	43182	8	Hex Bolt, 5/16-18 x 3/4"	19	R19212016	4	Washer, 5/8"
6	24908	1	Axle	20	43010	2	Cotter Pin
7	40880G	2	Wheel	21	23353	1	Hitch Pin
8	65442BL3	1	Rear Tongue	22	43001	2	Hex Bolt, 3/8-16 x 1"
9	24527BL3	1	Wheel Support	23	HA21362	5	Nylock Nut, 3/8-16
10	24497BL1	1	Latch Stand Bracket	24	43343	1	Hair Cotter Pin, 3/32"
11	25742BL3	1	Front Tongue	25	43574	3	Hex Bolt, 3/8-16 x 3"
12	27264BL1	1	Hitch Bracket	26	47407	1	Hex Bolt, 5/16-18 x 4"
13	25010BL1	1	Latch Lock Lever				
14	HA20186	1	Spring				

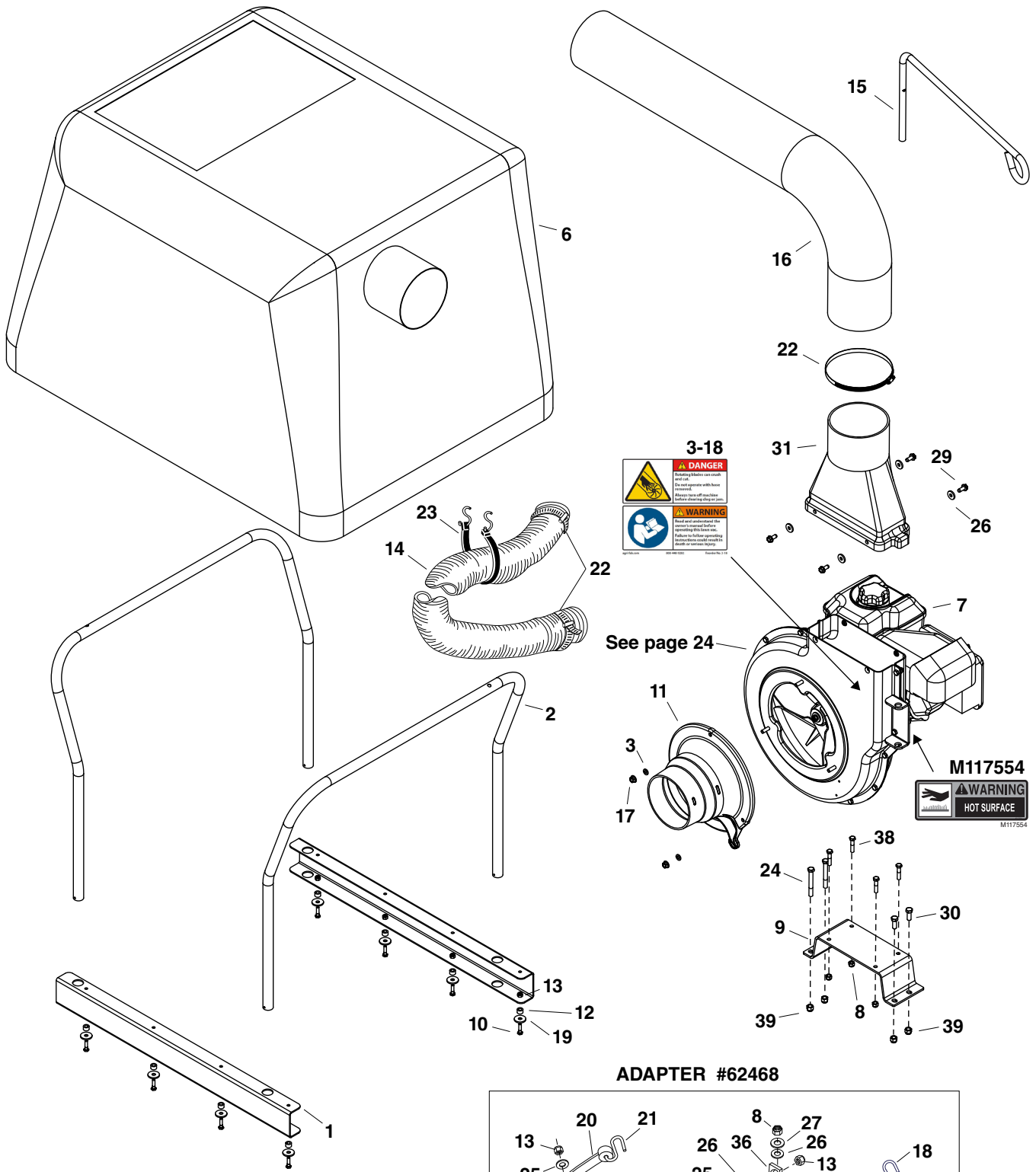

**3-18**  
**DANGER**  
 Exposed surfaces can become hot and can cause severe burns. Do not touch any hot surfaces. Do not touch any hot surfaces. Do not touch any hot surfaces.  
**WARNING**  
 Do not touch any hot surfaces. Do not touch any hot surfaces. Do not touch any hot surfaces. Do not touch any hot surfaces. Do not touch any hot surfaces.

See page 24

**M117554**  
**WARNING**  
 HOT SURFACE

**ADAPTER #62468**

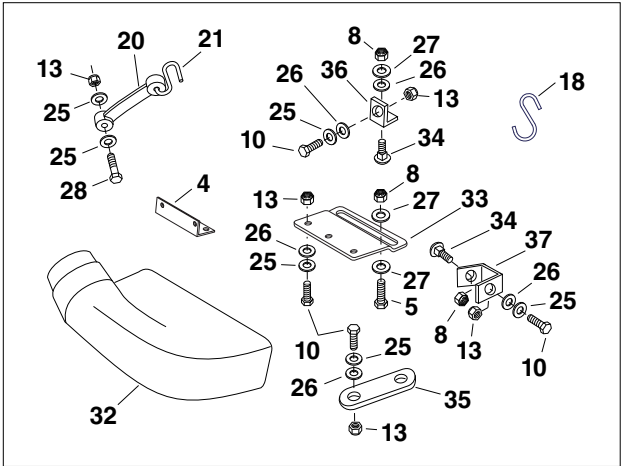

## REPAIR PARTS FOR MODEL 45-05671

REF. NO.	PART NO.	QTY.	DESCRIPTION	REF. NO.	PART NO.	QTY.	DESCRIPTION
1	45900BL3	2	SIDE RAIL	22	43793	3	Hose Clamp
2	45901BL3	2	TUBES, SUPPORT	23	43790	1	Tarp Strap, 25"
3	43086	3	Lock Washer, 5/16"	24	43574	2	Hex Bolt, 3/8-16 x 3"
4	27304BL1	1	Bracket, Attachment	25	43088	11	Washer, 1/4" Std.
5	43840	2	Hex Bolt, 5/16-18 x 1-1/4"	26	1543-69	9	Nylon Washer
6	45902	1	Cart Cover	27	43081	10	Washer, 5/16" Std.
7	2-735	1	Engine	28	1509-90	3	Hex Bolt, 1/4-20 x 1-1/4"
8	47810	7	Nylock Nut, 5/16-18	29	47630	4	Hex Bolt, 5/16-18 x 3/4"
9	25873BL1	1	Engine Mounting Base				(Thread Forming)
10	43661	15	Hex Bolt, 1/4-20 x 1"	30	43001	2	Hex Bolt, 3/8-16 x 1"
11	43791	1	Hose Adapter	31	45916	1	Transistion Snout
12	23727	8	Spacer, .310ID X .560OD	32	43830	1	Deck Adapter
13	47189	13	Nylock Nut, 1/4-20	33	23560BL1	1	Deck Adapter Bracket
14	2-17	1	Hose (long)	34	43080	2	Carriage Bolt, 5/16" x 3/4"
15	49974BL3	1	Hose Hanger Rod	35	23825	1	Mounting Strap
16	2-18	1	Hose (short)	36	23826	1	Angle Bracket
17	49983	3	Nut, Hex 5/16 Lock	37	23827	1	Mounting Bracket
18	42749	1	"S" Hook, Large	38	43085	4	Hex Bolt, 5/16-18 x 1-1/2"
19	736-0231	8	Washer, .344 X 1.125	39	HA21362	4	Nylock Nut, 3/8-16
20	44850	2	Tarp Strap		3-312	1	Owner's Manual
21	44849	2	"S" Hook				

## REPAIR PARTS LIST FOR 45-05671

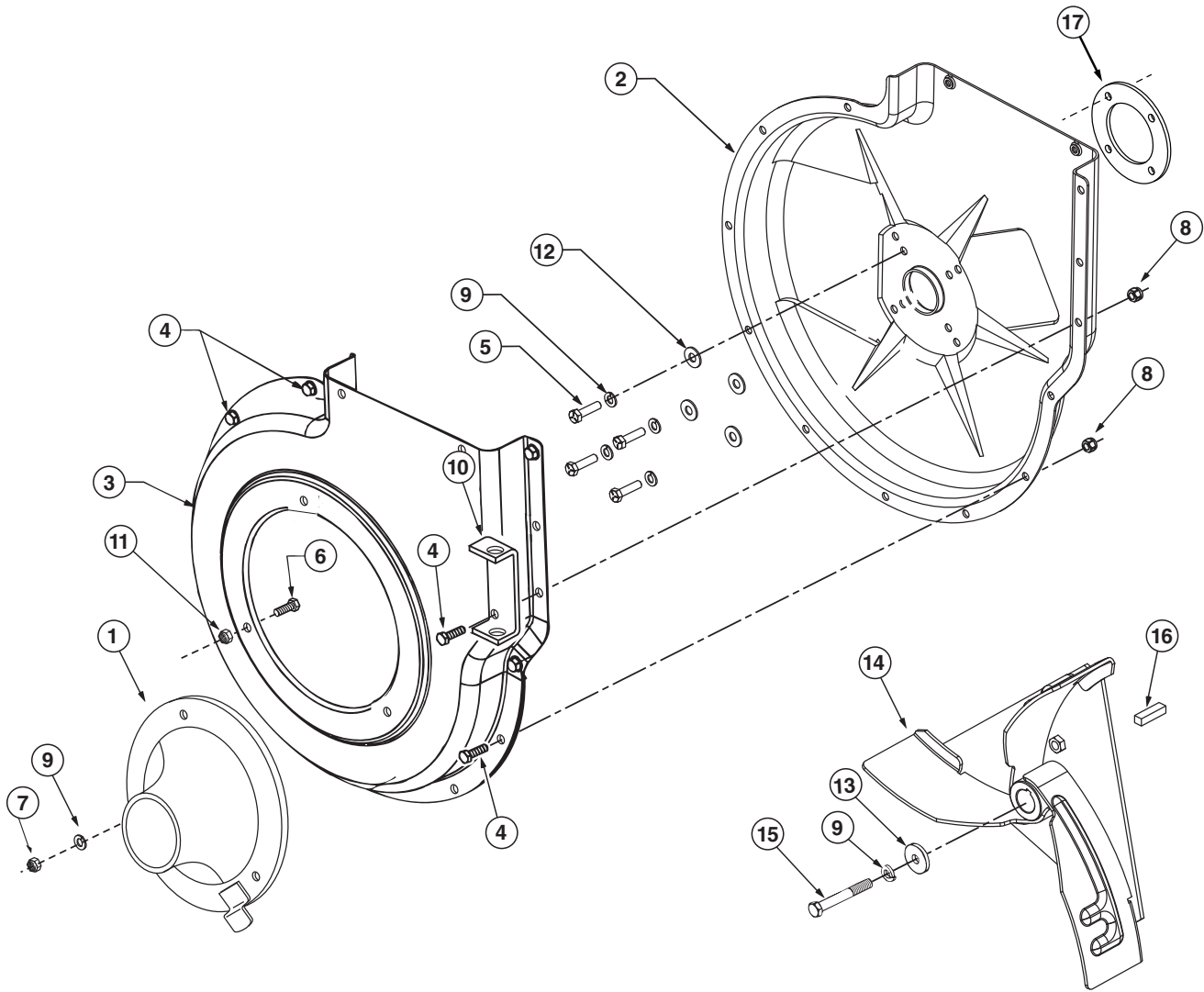

REF. NO.	PART NO.	QTY.	DESCRIPTION	REF. NO.	PART NO.	QTY.	DESCRIPTION
1	43791	1	Hose Adapter	10	24958BL1	1	Hose Hanger Bracket
2	27884BL3	1	Housing Assembly, Inner	11	46584	3	Hex Nut, Whizlock 5/16-18
3	24633BL3	1	Housing Assembly, Outer	12	43081	4	Washer, 5/16" Std.
4	43182	12	Hex Bolt, 5/16-18 x 3/4"	13	42828	1	Washer
5	47600	4	Hex Bolt, 5/16-24 x 1"	14	68669	1	Impeller Assembly
6	43063	3	Hex Bolt, 5/16-18 x 1"	15	45417	1	Hex Bolt, 5/16-24 x 1-3/4"
7	49983	3	Nut, Hex 5/16" Lock	16	HA11154	1	Key, 3/16" Sq. x 1.75"
8	47810	12	Nylock Nut, 5/16-18	17	28046BL1	1	Spacer, Inner Housing
9	43086	8	Lock Washer, 5/16"				



# SUGGESTED GUIDE FOR SIGHTING SLOPES FOR SAFE OPERATION OF TRACTOR WITH ATTACHMENT

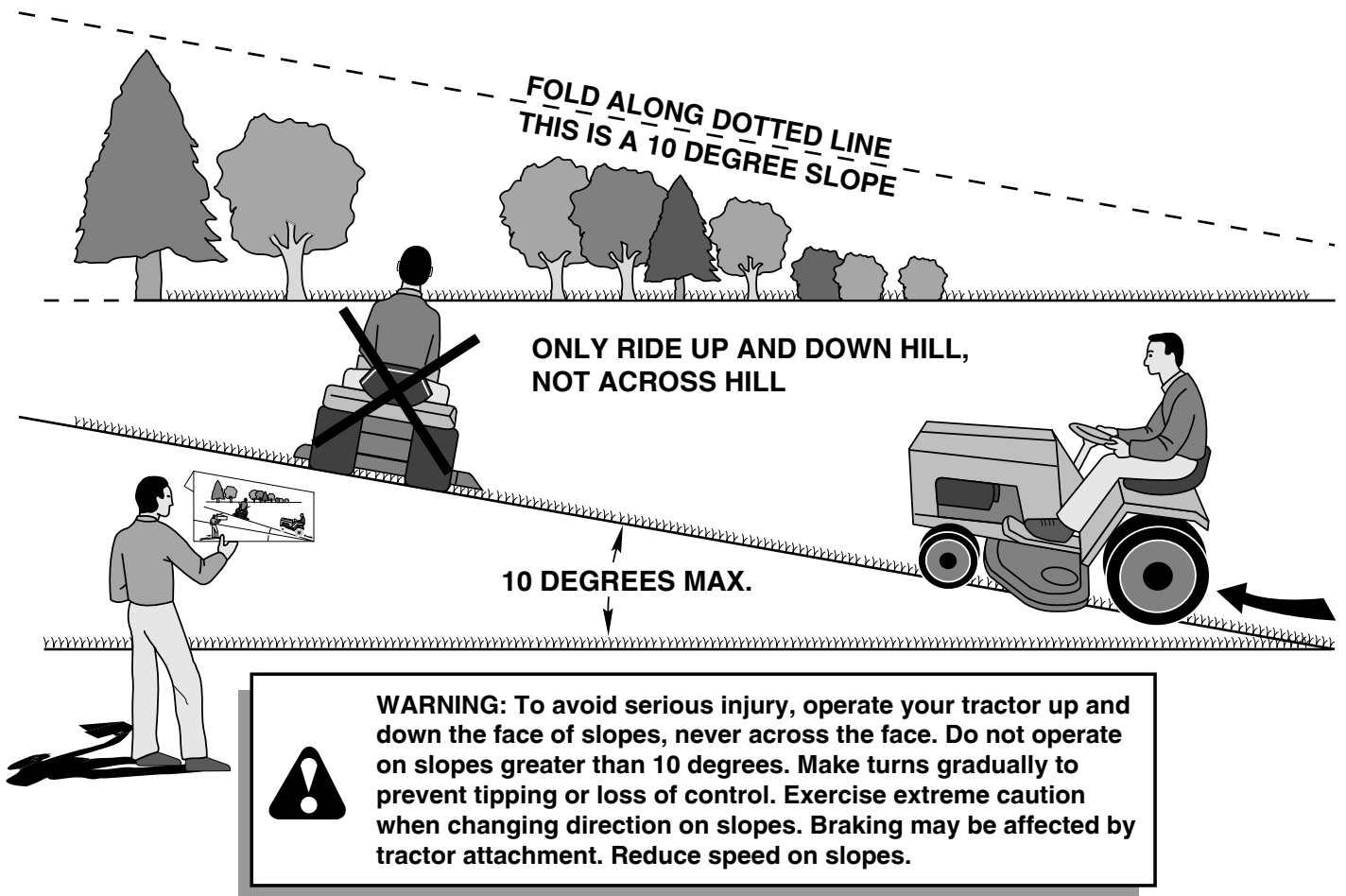

1. Fold this page along dotted line indicated above.
2. Hold page before you so that its left edge is vertically parallel to a tree trunk or other upright structure.
3. Sight across the fold in the direction of hill slope you want to measure.
4. Compare the angle of the fold with the slope of the hill.

THIS PAGE INTENTIONALLY LEFT BLANK

THIS PAGE INTENTIONALLY LEFT BLANK

***SpeedPart*** *the fastest way to purchase parts* [www.speedepart.com](http://www.speedepart.com)

**REPAIR PARTS**

Agri-Fab, Inc.  
809 South Hamilton  
Sullivan, IL. 61951  
217-728-8388  
[www.agri-fab.com](http://www.agri-fab.com)