



OWNERS MANUAL

**Model No.
45-03612**

CAUTION:
Read Rules for
Safe Operation
and Instructions
Carefully

- Safety
- Assembly
- Operation
- Maintenance
- Parts

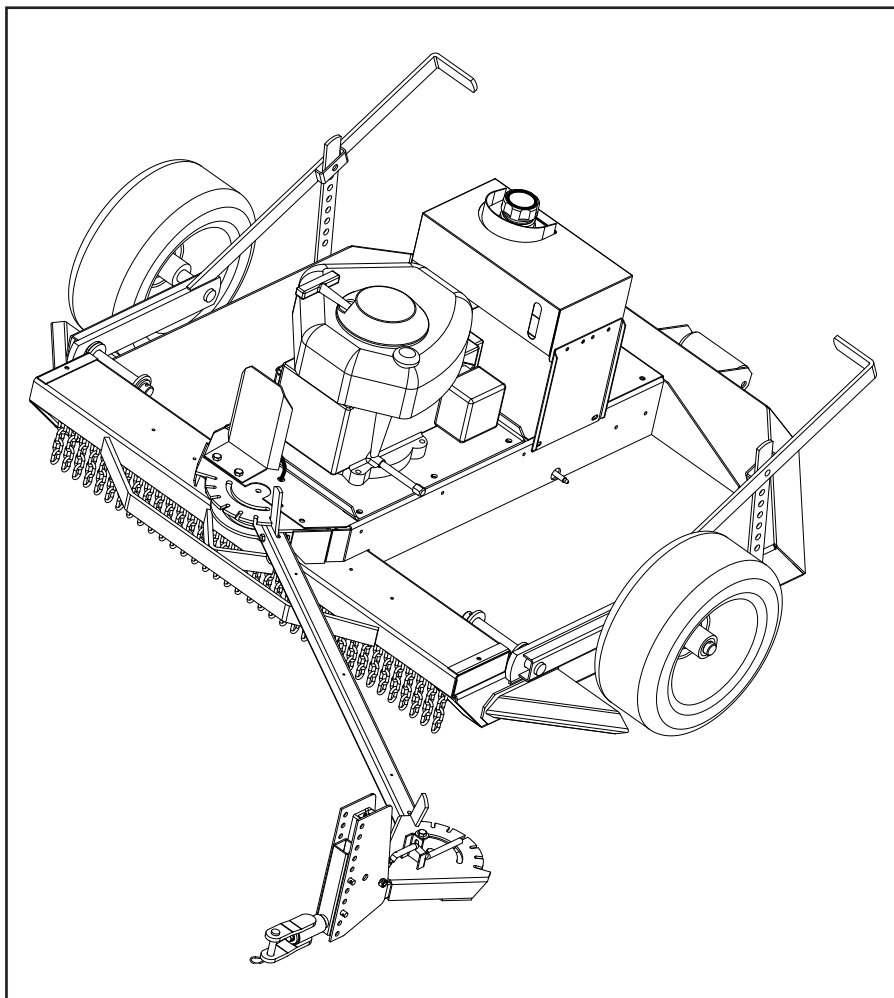

42" ROUGH CUT TRAILMOWER

Call 1-800-448-9282 for missing parts or assembly help.

SpeedPart *the fastest way to purchase parts* www.speedepart.com

TABLE OF CONTENTS

| | |
|-------------------------------------|-------|
| SAFETY RULES..... | 3,4 |
| SAFETY AND OPERATIONAL DECALS | 5,6 |
| HARDWARE CHART..... | 7 |
| ASSEMBLY..... | 8-11 |
| OPERATION..... | 12-16 |
| CUSTOMER RESPONSIBILITIES..... | 17-20 |
| STORAGE | 21 |
| REPAIR PARTS | 22-26 |
| WIRING DIAGRAM | 27 |

SAFETY RULES

Safe Operation Practices for Tow Behind Mowers

IMPORTANT: THIS CUTTING MACHINE IS CAPABLE OF AMPUTATING HANDS AND FEET AND THROWING OBJECTS. FAILURE TO OBSERVE THE FOLLOWING SAFETY INSTRUCTIONS COULD RESULT IN SERIOUS INJURY OR DEATH.

I. GENERAL OPERATION

- Read, understand, and follow all instructions in the manual and on the machine before starting.
- Read this operator's manual carefully. Become familiar with the controls and know how to operate your mower properly.
- Only allow responsible adults, who are familiar with the instructions, to operate the machine.
- Clear the area of objects such as rocks, toys, wire, etc., which could be picked up and thrown by the blade.
- Be sure the area is clear of other people before mowing. Stop machine if anyone enters the area.
- Never carry passengers.
- Do not mow in reverse unless absolutely necessary. Always look down and behind before and while backing.
- Slow down before turning.
- Never leave a running machine unattended. Always turn off blades, and stop engine.
- Turn off blades when not mowing.
- Mow only in daylight or good artificial light.
- Do not operate the machine while under the influence of alcohol or drugs.
- Watch for traffic when operating near or crossing roadways.
- Use extra care when loading or unloading the machine into a trailer or truck.
- Do not attempt to operate your tractor or mower when not in drivers seat.
- Disengage power to mower, stop engine when transporting or not in use.
- Exercise special care when mowing around fixed objects in order to prevent the blades from striking them. Never deliberately run tractor or mower onto or over any foreign object.
- Use mower only as the manufacturer intended and as described in this manual.
- Do not operate mower if it has been dropped or damaged in any manner. Always have damage repaired before using your mower.
- Always wear safety glasses or eye shields when starting and while using your mower.
- Dress properly. Do not operate mower when barefoot or wearing open sandals. Wear only solid shoes with good traction when mowing.
- Always make cutting height adjustments before starting your mower. Never attempt to do this while the engine is running.
- Keep your eyes and mind on your mower and the area being cut. Do not let other interests distract you.
- Do not put hands or feet near or under rotating parts. Keep clear of the discharge opening at all times.
- Before cleaning, inspecting, or repairing your mower, stop the engine and make absolutely sure the blade and all moving parts have stopped. Then disconnect the spark plug wire and keep it away from the spark plug to prevent accidental starting.
- Do not operate your mower if it vibrates abnormally. Excessive vibration is an indication of damage or unbalanced blades. Stop the engine, safety check for the cause of the vibration and repair as required.
- Never operate your mower without proper guards, plates, or other safety devices in place.

II. SLOPE OPERATION

Slopes are a major factor related to loss-of-control and tipover accidents, which can result in severe injury or death. All slopes require extra caution. If you feel uneasy on it, do not mow it.

DO:

- Mow up and down slopes, not across.
- Remove obstacles such as rocks, tree limbs, etc.
- Watch for holes, ruts, or bumps. Uneven terrain could overturn the machine. Tall grass can hide obstacles.
- Use slow speed. Choose a low gear so that you will not have to stop or shift while on the slope.
- Follow the tractor manufacturer's recommendations for wheel weights or counterweights to improve stability.
- Keep all movement on the slopes slow and gradual. Do not make sudden changes in speed or direction.
- Avoid starting or stopping on a slope. If tires lose traction, disengage the blades and proceed slowly straight down the slope.

DO NOT:

- Do not turn on slopes unless necessary, and then, turn slowly and gradually downhill, if possible.
- Do not mow near drop-offs, ditches, or embankments. The mower could suddenly turn over if a wheel is over the edge of a cliff or ditch, or if an edge caves in.
- Do not mow on wet grass. Reduced traction could cause sliding.

III. CHILDREN

Tragic accidents can occur if the operator is not alert to the presence of children. Children are often attracted to the machine and the mowing activity. Never assume that children will remain where you last saw them.

- Keep children out of the mowing area and under the watchful care of another responsible adult.
- Be alert and turn machine off if children enter the area.
- Before and when backing, look behind and down for small children.
- Never carry children. They may fall off and be seriously injured or interfere with safe machine operation.
- Never allow children to operate the machine.
- Use extra care when approaching blind corners, shrubs, trees, or other objects that may obscure vision.

IV. SERVICE

- Use extra care in handling gasoline and other fuels. They are flammable and vapors are explosive.
 - Use only an approved container.
 - Never remove gas cap or add fuel with the engine running. Allow engine to cool before refueling. Do not smoke.
 - Never refuel the machine indoors.
 - Never store the machine or fuel container inside where there is an open flame, such as a water heater.
- Never run a machine inside a closed area.
- Keep nuts and bolts, especially blade attachment nuts, tight and keep equipment in good condition.
- Never tamper with safety devices. Check their proper operation regularly.
- Keep machine free of grass, leaves, or other debris build-up. Clean oil or fuel spillage. Allow machine to cool before storing.
- Stop and inspect the equipment if you strike an object. Repair, if necessary, before restarting.
- Never make adjustments or repairs with the engine running.
- Mower blades are sharp and can cut. Wrap the blade(s) or wear gloves, and use extra caution when servicing them.
- Check brake operation frequently. Adjust and service as required.



Look for this symbol to point out important safety precautions. It means CAUTION!!! BECOME ALERT!!! YOUR SAFETY IS INVOLVED.



CAUTION: Always disconnect spark plug wire and place wire where it cannot contact spark plug in order to prevent accidental starting when setting up, transporting, adjusting or making repairs.



SAFETY AND OPERATIONAL DECALS

Replace decal immediately if damaged. Order by part number. See back cover.



HA12315 DANGER DECAL



HA12314 DANGER ROTATING BLADES DECAL

HOW TO USE MOWER

STOPPING

- Move blade clutch lever to OFF position.
- Move engine shut off switch to OFF position.
- Move engine throttle to SLOW position

STARTING

- Move engine shut off switch to ON position.
- Move blade clutch lever to OFF position.
- Move engine throttle to CHOKE position.
- Pull start rope.
- Move engine throttle to run position after engine starts.

USE

- Raise blade clutch lever to engage position.
- Operate tow vehicle at a ground speed of approximately 3 to 4 MPH.

TRANSPORTING

- Shut off engine.
- Place mower deck in the highest position directly behind tow vehicle.

HA24365

CAUTION

- READ, UNDERSTAND, AND FOLLOW ALL INSTRUCTIONS IN THE MANUAL AND ON THE MACHINE BEFORE STARTING.
- ALLOW ONLY RESPONSIBLE ADULTS, WHO ARE FAMILIAR WITH THE INSTRUCTIONS, TO OPERATE THE MACHINE.
- CLEAR THE AREA OF OBJECTS SUCH AS ROCKS, TOYS, WIRE, ETC., WHICH COULD BE PICKED UP AND THROWN BY THE BLADE.
- BE SURE THE AREA IS CLEAR OF OTHER PEOPLE BEFORE MOWING. STOP MACHINE IF ANYONE ENTERS THE AREA.
- KEEP ALL SAFETY FEATURES IN PLACE AND OPERATING.
- NEVER LEAVE A RUNNING MACHINE UNATTENDED. ALWAYS TURN OFF BLADES, SET PARK BRAKE, AND STOP ENGINE.
- AVOID CONTACT WITH MOVING PARTS. KEEP HANDS AND FEET AWAY FROM BLADES.
- STOP ENGINE BEFORE FUELING, ADJUSTING, OR INSPECTING. DO NOT ADD FUEL TO AN ENGINE THAT IS HOT OR RUNNING.

HA24365 CLUTCH LEVER DECAL

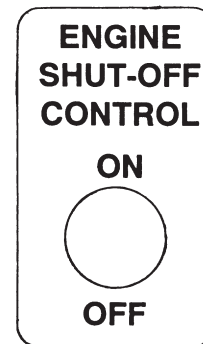

HA23262 ENGINE SHUT-OFF OPERATION DECAL



SAFETY AND OPERATIONAL DECALS

Replace decal immediately if damaged. Order by part number. See back cover.



HA23265 CLUTCH LEVER OPERATION DECAL

CONTENTS OF PARTS BAG

SHOWN FULL SIZE

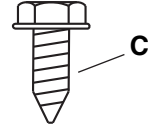
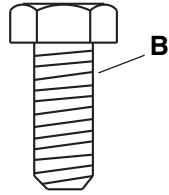
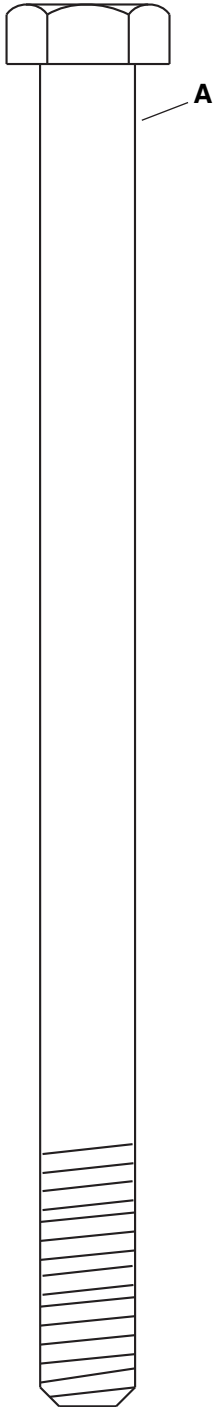

NOT SHOWN FULL SIZE



| REF. | QTY. | DESCRIPTION | REF. | QTY. | DESCRIPTION |
|------|------|--------------------------------|------|------|---------------------|
| A | 1 | Hex Bolt, 1/2" x 7" | D | 1 | Nyock Jam Nut, 1/2" |
| B | 2 | Hex Bolt, 5/16" x 3/4" | E | 2 | Nylock Nut, 5/16" |
| C | 3 | Screw, Self Tapping #10 x 1/2" | F | 3 | Clip, 3/8" |

ASSEMBLY

TOOLS REQUIRED FOR ASSEMBLY

- (1) 5/16" Wrench
- (2) 7/16" Wrenches
- (2) 1/2" Wrenches
- (2) 9/16" Wrenches
- (2) 3/4" Wrenches or Adjustable Wrenches

UNPACKING

- Enclosed in packing crate are four items:
 - Mower Deck
 - Tow Bar Hitch Assembly
 - Box of Parts consisting of:
 - Rear Roller
 - Rear Roller Bracket
 - Bag of Parts (See page 7)

ENGINE OIL

VERY IMPORTANT:

Engine must be filled with oil before operation. See OIL & FUEL RECOMMENDATIONS in engine Owner's Manual for correct filling instructions and oil fill capacity.

INSTALL TOWBAR TUBE TO REAR QUADRANT

- Remove Hex Bolts and lift Front Drive Cover from mower housing.
- Rest end of Tow Bar Tube on front edge of mower.
- Feed Wire Harness in end of Tow Bar Tube through large hole in back wall of Rear Quadrant.
- Place Towbar Tube into Rear Quadrant, align holes and insert 3/8 x 2-3/4 Hex Bolt through quadrant and rear hole of Tube.
- Secure tightly with 3/8 Hex Lock Nut and then loosen 1/4 turn to allow Tube to pivot freely inside Rear Quadrant.
- Assemble a 3/8 Flat Washer onto a 3/8 x 2-3/4 Hex Bolt.
- Insert Bolt and Washer into slot in Rear Quadrant and into hole in Towbar Tube.
- Secure Tightly with 3/8 Flat Washer and 3/8 Hex Lock Nut, then loosen 1/4 turn to allow Tube to pivot freely inside Rear Quadrant.

NOTE: Towbar Tube must pivot freely inside Rear Quadrant when Latch is pulled from notch.

INSTALL WIRE HARNESS TO ENGINE

- Feed Wire Harness up through hole in middle of Front Drive Cover.
- Install one Wire to Engine Magneto Ground Terminal. (The same Terminal as red Wire from inside Mower.)
- Install other Wire of Wire Harness to Engine Ground Base. (The same Terminal as black Wire from inside Mower.)
- Refasten Front Drive Cover to mower housing.

INSTALL CLUTCH TO TOWBAR TUBE

- Place Clutch Cable forward along Towbar Tube.
- Spread ends of three Cable Clips and place around Clutch Cable.
- Place Clutch Cable on top of Towbar Tube and align Cable Clips with bolt holes in Towbar Tube.
- Secure with three #10 Screws.

INSTALL CLUTCH CABLE TO CLUTCH LEVER

- Remove outer 5/16 Nut from end of Clutch Cable Housing. (See Fig. 1)
- Turn inner 5/16 Nut to bottom of thread.
- Insert Cable and outer 5/16 Nut through slotted hole in Cable Guide of Hitch Assembly. The outer 5/16 Nut must be cocked sideways to insert through slotted hole of Cable Guide.
- Reinstall outer 5/16 Nut to the cable housing to secure Cable Harness to Cable Guide.
- Install mounting anchor of clutch cable to clutch lever using clevis pin and hair cotter pin.

ASSEMBLY

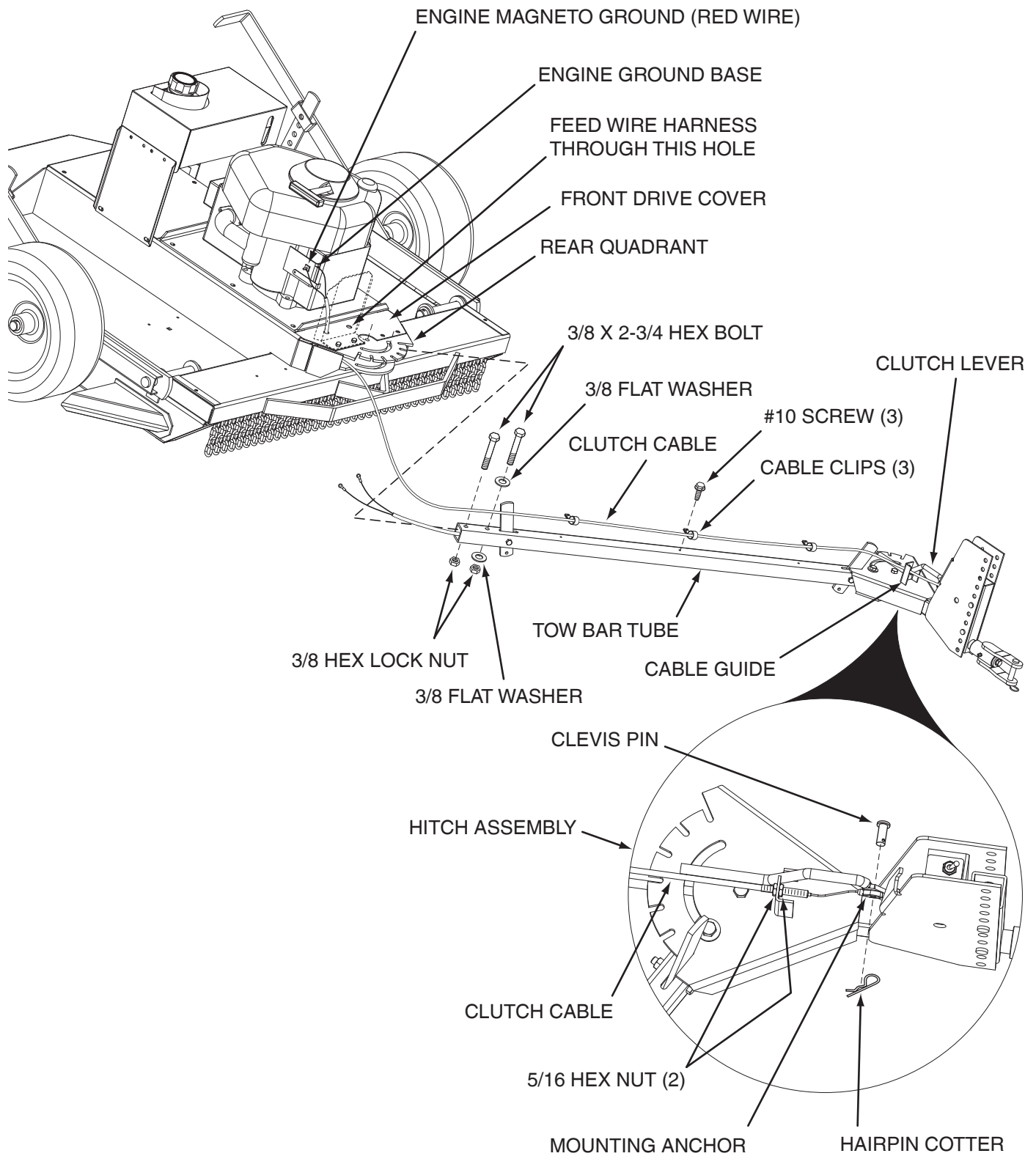
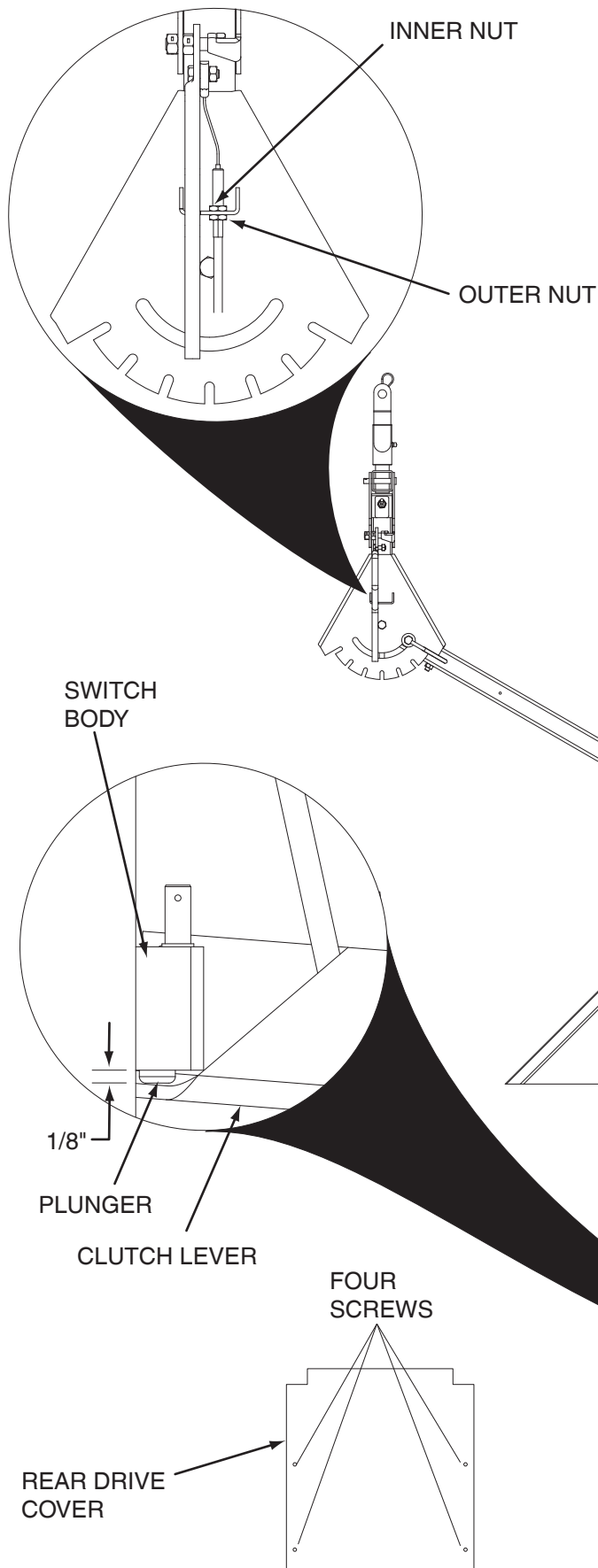

FIG. 1

ASSEMBLY



CLUTCH CABLE ADJUSTMENT

- Remove four screws from Rear Drive Cover. Lay aside cover and screws.
- Place Clutch Lever in "DISENGAGED" position
- The Cable should be under slight tension but should not pull the Clutch Lever more than 1/8" away from the Switch Body.

NOTE: If the Plunger extends more than 1/8" out from the switch body, the cable tension is too tight and the Engine will not start.

TO INCREASE CABLE TENSION

- Place Blade Clutch Lever in the "DISENGAGED" position.
- Loosen the inner nut on the Clutch Cable.
- Tighten the outer nut on the Clutch Cable.

TO DECREASE CABLE TENSION

- Place Blade Clutch Lever in the "DISENGAGED" position.
- Loosen the outer nut on the Clutch Cable.
- Tighten the inner nut on the Clutch Cable.
- Repeat the above procedure until you have the correct tension.

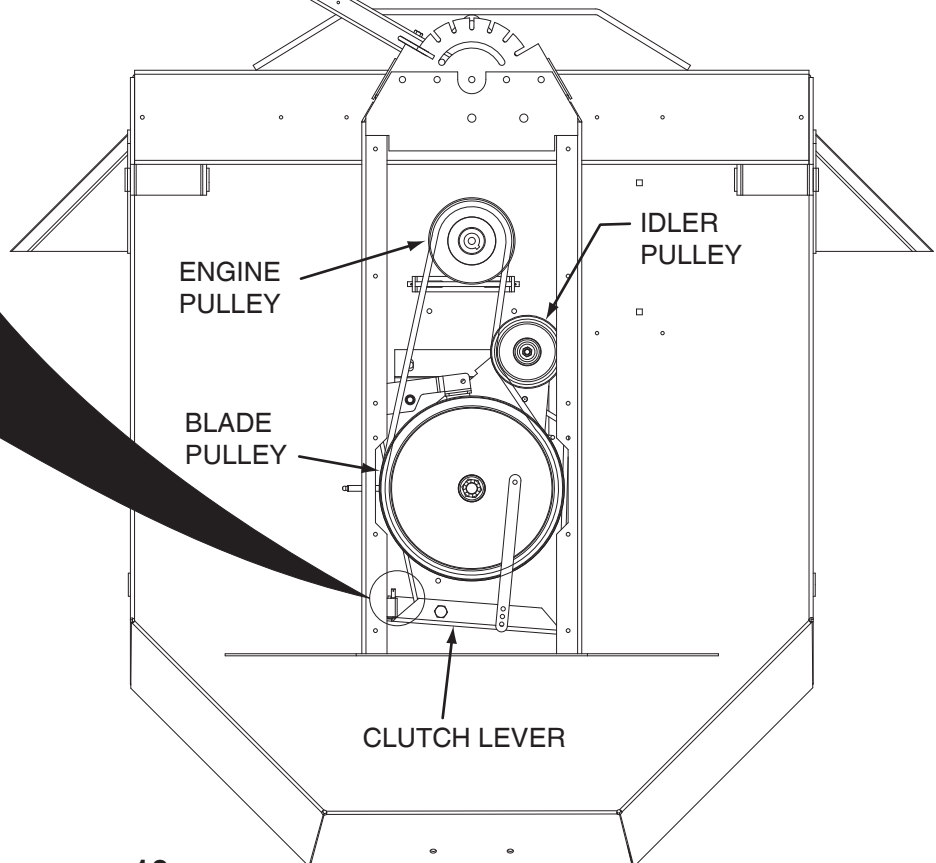

FIG. 2

ASSEMBLY

INSTALL REAR ROLLER TO DECK

- Install Rear Roller Mounting Bracket to rear of deck using two 5/16 x 3/4 Hex Bolts and two 5/16 Nylock Nuts from parts bag. (See Fig. 3.)
- Install Roller to Rear Roller Bracket using 1/2 x 7 Hex Bolt and 1/2 Nylock Jam Nut from parts bag.
- Make sure Roller turns freely on Bolt.

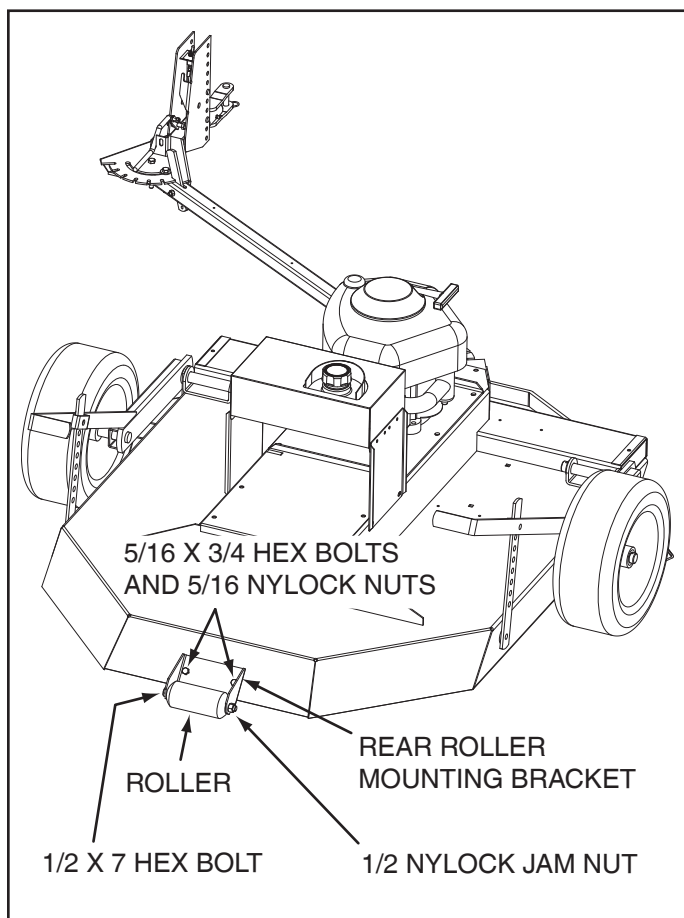

FIG. 3

OPERATION

KNOW YOUR MOWER

READ THIS OWNER'S MANUAL AND SAFETY RULES BEFORE OPERATING YOUR MOWER.

Compare the illustrations with your mower to familiarize yourself with the location of various controls and adjustments. Save the manual for future reference.

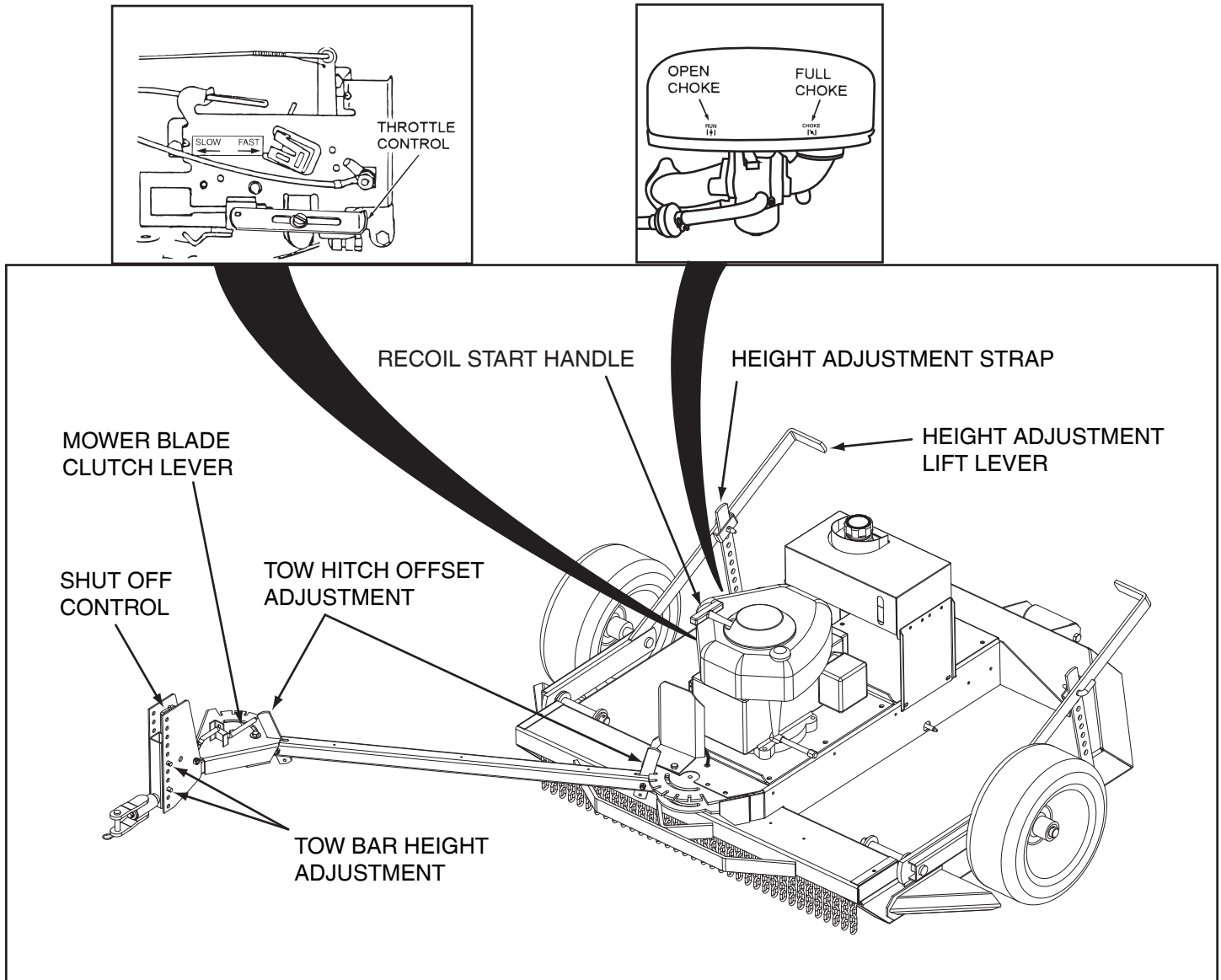

FIG. 4

MOWER BLADE CLUTCH LEVER - Starts and stops mower blade rotation
THROTTLE CONTROL - Controls engine speed, engine shut-off
SHUT OFF CONTROL - Used to shut off mower engine from tractor seat
HEIGHT ADJUSTMENT LIFT LEVER - Raise and lower mower to different cutting heights

HEIGHT ADJUSTMENT STRAP - Controls cutting height
TOW BAR HEIGHT ADJUSTMENT - To level mower front to rear
RECOIL START HANDLE - Used to start engine
TOW HITCH OFFSET ADJUSTMENT - To adjust mower deck offset from tractor center
CHOKE CONTROL - Opens and closes choke

OPERATION



The operation of any mower can result in foreign objects being thrown into the eyes, which can result in severe eye damage. Always wear safety glasses or eye shields before starting your mower and while mowing. We recommend wide vision safety mask for over the spectacles or standard safety glasses.

CHILDREN



Tragic accidents can occur if the operator is not alert to the presence of children. Children are often attracted to the machine and the mowing activity. **Never** assume that children will remain where you last saw them.

ENGINE OIL

VERY IMPORTANT:

Engine must be filled with oil before operation. See OIL & FUEL RECOMMENDATIONS in engine Owner's Manual for correct filling instructions and oil fill capacity.

HOW TO USE YOUR MOWER

STOPPING

- Move blade clutch lever to Off position.
- Move engine shut off switch to Off position.
- Move engine throttle to Stop position.

STARTING

- Move engine shut off switch to On position.
- Move engine throttle to Full position.
- Move choke to full.
- Move blade clutch lever to Off position.
- Pull start rope.
- Move engine choke to Off position after engine starts.

USE

- Sit on tow vehicle seat.
- Raise blade clutch lever to Engage position.
- Operate tractor at medium ground speed.
- (3-4 MPH)

TRANSPORTING

- Shut off engine.
- Place mower deck in the highest position directly behind tow vehicle.

ATTACHING MOWER TO TOW VEHICLE

- Place mower behind tow vehicle and back vehicle up to it for attaching. (See Fig. 5)
- Place tow bar of mower down onto tow bar on tow vehicle.
- Secure tow bar of mower to tow bar on tow vehicle with hitch pin and hair cotter pin.

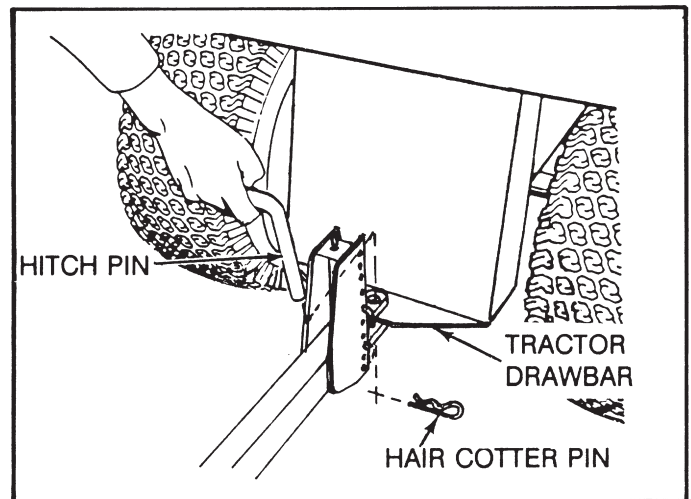

FIG. 5

HINT: To help prevent flat tires caused by punctures during rough use, use a tire sealant product such as SLIME®, following the instructions on the product container. Purchase at your local hardware store.

OPERATION

MOWER HEIGHT ADJUSTMENT



CAUTION:
SHUT OFF MOWER ENGINE AND REMOVE SPARK PLUG WIRE FROM SPARK PLUG BEFORE MAKING ANY ADJUSTMENTS TO THE MOWER

The cutting height range is approximately 1-1/2 to 5 inches. The heights are measured from the ground to the blade tip with the engine not running. These heights are approximate and may vary depending upon soil conditions, height of brush and types of brush being mowed.

CUTTING HEIGHT ADJUSTMENTS

- To adjust the mower cutting height remove hair cotter pin from locating pin. (See Fig. 6)
- Apply down pressure to height adjustment lift lever.
- Remove the locating pin from the height adjustment strap.
- Move height adjustment strap up or down to align it with the desired hole in the height adjustment strap.
- Reassemble locating pin to the height adjustment strap and secure with hair cotter pin.
- Make sure that both side height adjustment straps are adjusted to the same height.

FRONT TO BACK RAKE ADJUSTMENT

To obtain the best cutting results, the mower housing should be adjusted so that the front is approximately 1/4" to 3/4" lower than the rear. To check front to back adjustment measure from the bottom edge of the deck to the ground at both front and rear of the deck.

TO ADJUST MOWER FROM FRONT TO BACK

- Remove two hair cotter pins from two clevis pins in the tow bar adjustment. (See Fig. 6)
- Remove two clevis pins from tow bar adjustment.
- Raise or lower the tow bar to obtain the proper front to back adjustment.
- Reassemble two clevis pins to tow bar adjustment and secure with two hair cotter pins.

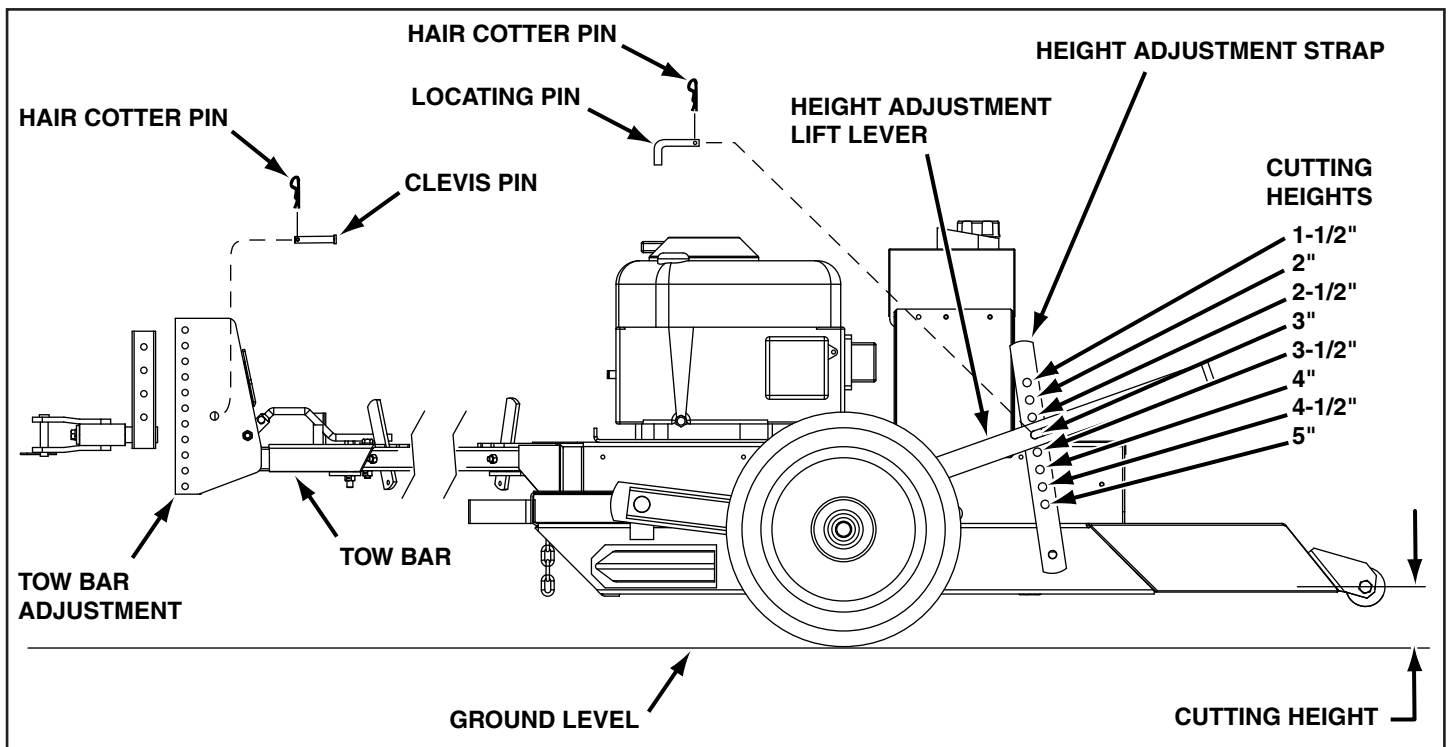

FIG. 6

OPERATION

TOW HITCH OFFSET ADJUSTMENT

This mower has been designed to run offset from the center of the tow vehicle. This allows the operator to drive along side high brush with the tow vehicle while cutting down the brush beside him. The adjustable hitch gives you three offset cutting positions plus straight behind for narrow paths.

MODEL 45-03071

The adjustable hitch of this mower can be set in seven positions including straight and offsets of 15", 29" and 39" on both sides.

MODEL 45-0361

The adjustable hitch of this mower can be set in seven positions including straight and offsets of 9", 17" and 23" on both sides.

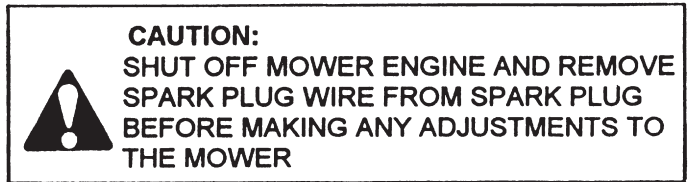
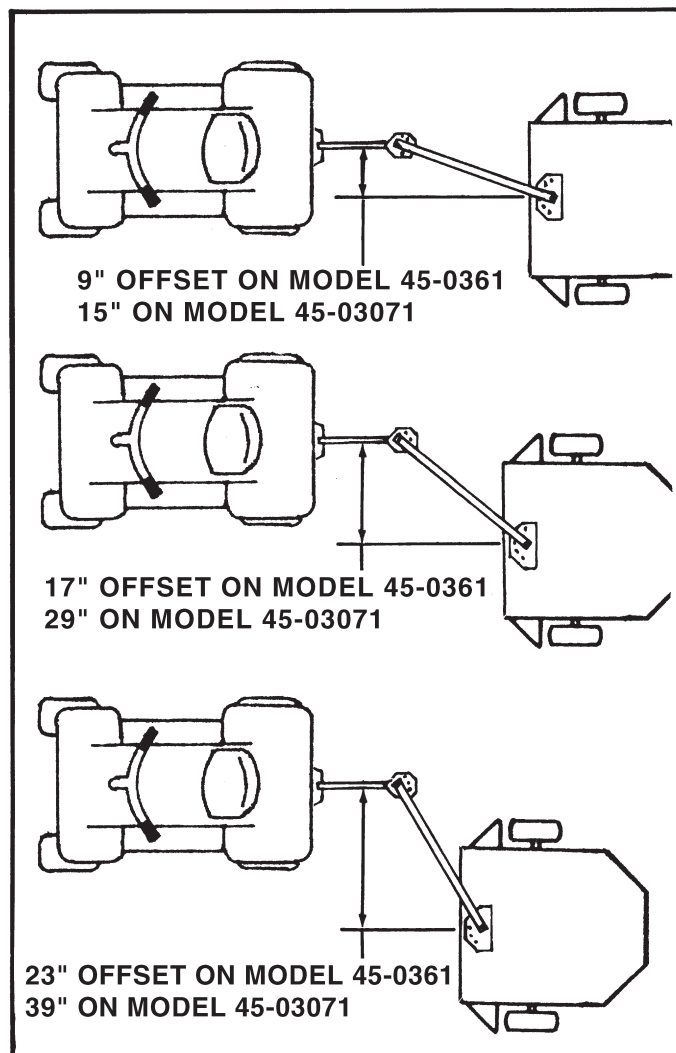

TO ADJUST THE OFFSET HITCH

- Pull back the pivot latch from the notch of the front quadrant. Adjust the hitch tube to the desired offset and release the pivot latch into the notch of the quadrant. (See Fig. 8)
- Pull back the pivot latch from the notch of the rear quadrant. Adjust the hitch tube to the corresponding notch of the front quadrant and release the pivot latch into the notch.

IMPORTANT: The hitch tube must be assembled to the same offset notch in both the front and rear quadrants.

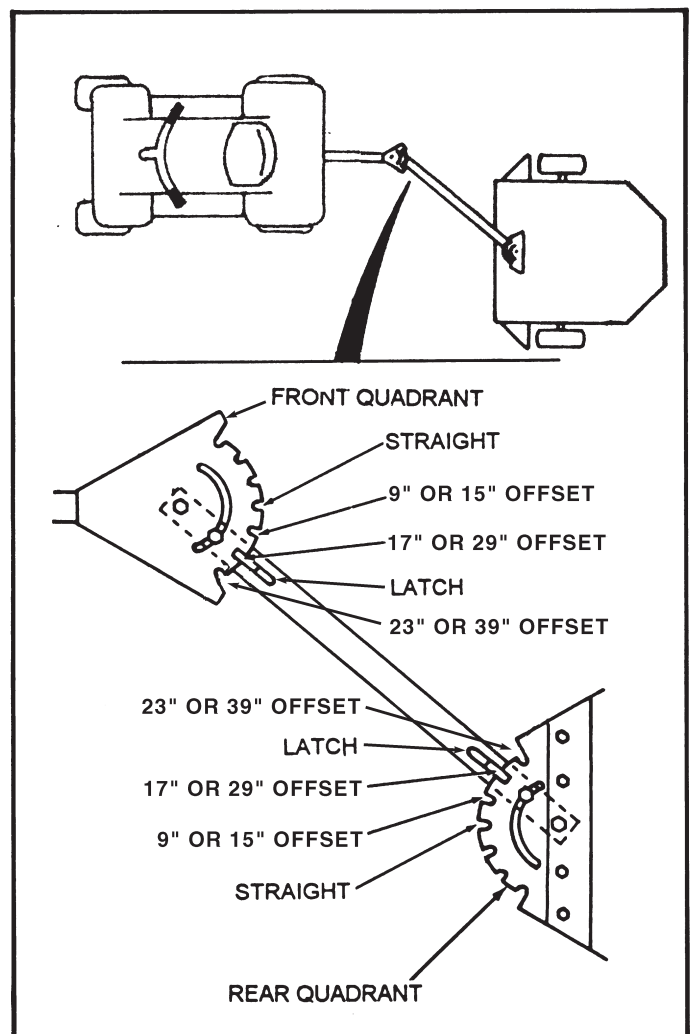

OPERATION

BEFORE STARTING ENGINE

- Fill engine with oil. (See engine manual for proper procedure and requirements)
- Add gasoline. Fill fuel tank using fresh clean unleaded gasoline. (See engine manual for safe filling procedure and storage instructions)



CAUTION:
FILL TO BOTTOM OF FUEL TANK FILLER NECK. DO NOT OVERFILL. WIPE OFF ANY SPILLED OIL OR FUEL. DO NOT STORE, SPILL OR USE GASOLINE NEAR OPEN FLAME

TO START ENGINE



CAUTION:
KEEP THE BLADE CLUTCH LEVER IN "DISENGAGED" POSITION WHEN STARTING ENGINE

- Make sure spark plug wire is properly connected.
- Place choke control in "CHOKE" position if the engine is cold. A warm engine may not require choking to start.
- Move engine throttle to full position.
- Grasp starter handle with one hand. Pull rope out slowly until engine reaches start of compression cycle (rope will pull slightly harder at this point)
- Pull rope with a rapid, continuous, full arm stroke.
- Keep a firm grip on starter handle and let rope rewind slowly. Do not let starter handle snap back against starter.
- When engine starts move choke to open position.
- Allow engine to warm up for a few minutes before engaging blades.

NOTE: If at a high altitude (above 3000 feet) or in cold temperatures (below 32°F), the carburetor fuel mixture may need to be adjusted for best performance. (See Service and Adjustments section of the engine manual.)

BREAKING IN YOUR MOWER

Break in your belts, pulleys, and engine before you actually begin mowing.

- Start engine, engage blade control to start blades rotating and allow blades to rotate for approximately five minutes to break in mower and engine.



CAUTION:
CHECK AREA UNDER AND AROUND MOWER FOR ANY OBJECTS THAT COULD BE THROWN FROM UNDER MOWER. MAKE SURE THAT MOWER DISCHARGE AREA IS CLEAR.

MOWING PROCEDURES



CAUTION:
TRAGIC ACCIDENTS CAN OCCUR IF THE OPERATOR IS NOT ALERT TO THE PRESENCE OF CHILDREN. CHILDREN ARE OFTEN ATTRACTED TO THE MACHINE AND THE MOWING ACTIVITY. NEVER ASSUME THAT CHILDREN WILL REMAIN WHERE YOU LAST SAW THEM.



CAUTION:
NEVER CARRY CHILDREN. THEY MAY FALL OFF AND BE SERIOUSLY INJURED OR INTERFERE WITH SAFE OPERATION

Mowing should be started with tow vehicle in low gear and speed increased only as mowing conditions will safely permit.

Mower will perform at its best when engine throttle is set for full throttle.

Always operate mower engine at full throttle when mowing to assure better mowing performance and proper discharge of material. Regulate ground speed by selecting a low enough gear to give the mower cutting performance as well as the quality of cut desired.

When operating any attachment select a ground speed that will suit the terrain and give best performance of the attachment being used.

IMPORTANT: Avoid prolonged mowing of ditches with slopes greater than 15 degrees. Small engines become starved for oil at angles greater than 15 degrees and should only be used for brief periods on such slopes. Be sure the engine is filled to the maximum oil level when mowing on slopes.

CUSTOMER RESPONSIBILITIES

GENERAL RECOMMENDATIONS

The warranty on this Vehicle does not cover items that have been subjected to operator abuse or negligence. To receive full value from the warranty, operator must maintain unit as instructed in this manual.

Some adjustments will need to be made periodically to properly maintain your unit. All adjustments in the Service and Adjustments section of this manual should be checked at least once each season.

- Once a year you should replace the spark plug, clean or replace air filter, and check blades and belts for wear. A new spark plug and clean air filter assure proper air-fuel mixture and help your engine run better and last longer.

BEFORE EACH USE

- Check engine oil level.
- Check blade operation
- Check for loose fasteners.

LUBRICATION

Keep unit well lubricated (See "LUBRICATION CHART").

| MAINTENANCE SCHEDULE | SERVICE INTERVALS | | | | SERVICE DATES | | | | | | | | | | | | | | | | | |
|--------------------------------|-------------------|---------------|---------------|-----------------------------|---------------|--|--|--|--|--|--|--|--|--|--|--|--|--|--|--|--|--|
| | BEFORE EACH USE | FIRST 2 HOURS | EVERY 5 HOURS | EVERY 25 HOURS OR EACH YEAR | LEVIS PIN | | | | | | | | | | | | | | | | | |
| Check Engine Oil Level | ✓ | | ✓ | | | | | | | | | | | | | | | | | | | |
| Change Engine Oil | | ✓ | | ✓ ^{1,2} | | | | | | | | | | | | | | | | | | |
| Inspect Spark Arrester Muffler | | | | ✓ | | | | | | | | | | | | | | | | | | |
| Inspect Air Screen | ✓ | | | | | | | | | | | | | | | | | | | | | |
| Check and Clean Air Cleaner | | | ✓ | | | | | | | | | | | | | | | | | | | |
| Replace Air Cleaner Cartridge | | | | ✓ ² | | | | | | | | | | | | | | | | | | |
| Clean Engine Cylinder Fins | | | | ✓ | | | | | | | | | | | | | | | | | | |
| Replace Spark Plug | | | | ✓ | | | | | | | | | | | | | | | | | | |
| Lubricate Spindle | | | | ✓ | | | | | | | | | | | | | | | | | | |

- 1 - Change more often when operating under a heavy load or in high ambient temperatures.
- 2 - Service more often when operating in dirty or dusty conditions.

LUBRICATION CHART

- ① REFER TO ENGINE MANUAL
- ② GENERAL PURPOSE GREASE
- ③ DRY LUBRICANT

IMPORTANT: DO NOT OIL OR GREASE PIVOT POINTS. VISCOUS LUBRICANTS WILL ATTRACT DUST AND DIRT THAT CAN CAUSE WEAR ON PIVOT POINTS. IF YOU FEEL THEY MUST BE LUBRICATED, USE ONLY A DRY POWERED GRAPHITE TYPE LUBRICANTS.

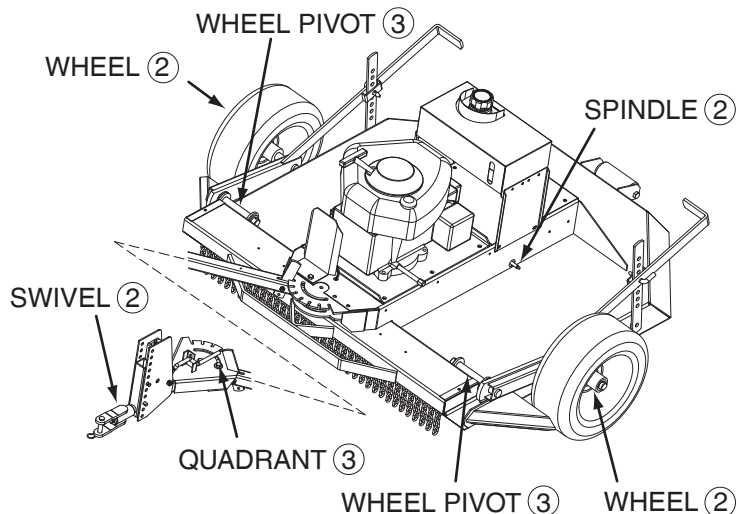

CUSTOMER RESPONSIBILITIES

BLADE CARE AND SERVICE



CAUTION:

DO NOT HANDLE MOWER BLADES WITH BARE HANDS. CARELESS OR IMPROPER HANDLING MAY RESULT IN SERIOUS INJURY.

BLADE CARE

For best results mower blades must be kept sharp. The blades can be sharpened with a file or on a grinding wheel. Do not attempt to sharpen blades while they are still on the mower.

BLADE SERVICE (Refer to fig. 9)

TO REMOVE BLADE ASSEMBLY FROM DECK

- Remove cotter pin from the spindle shaft.
- Remove nut and washer from the spindle shaft.
- Pull blade assembly off the spindle shaft. (Watch for a key in the spindle shaft.)

TO REMOVE BLADES FROM BLADE ASSEMBLY.

- Remove cotter pin from the blade bolt.
- Remove nut from the blade bolt.
- Remove blade from the blade assembly.

BLADE SHARPENING

- Blades can be sharpened with a file or grinding wheel.
- NOTE: When sharpening blades take care to maintain blade balance. Sharpen both blades equally even if one blade does not need to be sharpened. Check balance by weighing each blade to make sure they are equal in weight.



CAUTION:

IF YOUR BLADE BOLTS SHOW WEAR, REPLACE THEM WITH FACTORY REPLACEMENTS ONLY.

TO REINSTALL BLADES

- Assemble a blade bolt through a flat washer, a blade and then another flat washer.
- Assemble the bolt through the hole in the stump plate and the blade hub assembly.
- Assemble a flat washer and nut onto the blade bolt.
- Tighten nut, then loosen just until blade can pivot.
- Install a cotter pin to secure the nut.

TO REINSTALL BLADE ASSEMBLY TO MOWER

- Reinstall key in spindle shaft, if necessary.
- Install the blade assembly onto the spindle shaft.
- Secure with flat washer and nut.
- Torque the spindle shaft and nut to 100 FT. LBS. and secure with a hair cotter pin.

BLADE ASSEMBLY

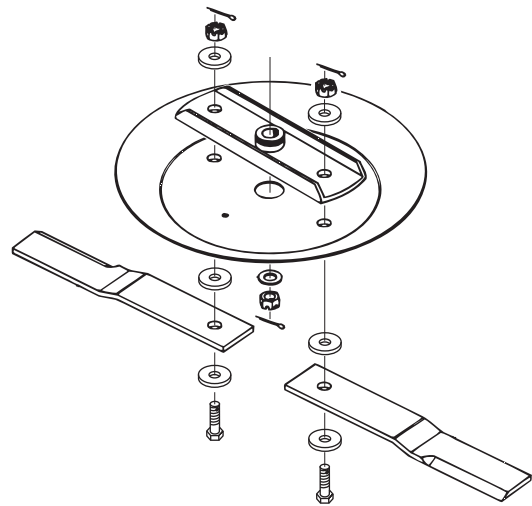

FIG. 9



WARNING:

SHUT OFF MOWER ENGINE AND REMOVE SPARK PLUG WIRE FROM SPARK PLUG BEFORE MAKING ANY ADJUSTMENTS OR REPAIRS TO THE MOWER.

CLEANING THE MOWER

Water pressure from a garden hose will remove fresh clippings from the underside of the mower. Clean mower after each mowing.

DAILY MAINTENANCE

Make sure all nuts and bolts are tight, cotter pins and retainer springs are secure. Keep blades sharp. Observe all Safety Precautions. Keep mower well lubricated.

REPAIR PARTS

Your rotary mower has been produced with components designed for your unit. Although standard V-belts, bearings, blades, pulleys, etc. may look like parts used on your rotary mower, while similar in appearance many are of a different construction and could in some cases cause a malfunction in the operation of the machine.

For continued satisfactory performance use only repair parts supplied by the manufacturer. See the dealer where the mower was purchased for factory replacement parts.

CUSTOMER RESPONSIBILITIES

CLUTCH CABLE ADJUSTMENT

- Remove four screws from Rear Drive Cover. Lay aside cover and screws.
- Place Clutch Lever in "DISENGAGED" position
- The Cable should be under slight tension but should not pull the Clutch Lever more than 1/8" away from the Switch Body.

NOTE: If the Plunger extends more than 1/8" out from the switch body, the cable tension is too tight and the Engine will not start.

TO INCREASE CABLE TENSION

- Place Blade Clutch Lever in the "DISENGAGED" position.
- Loosen the inner nut on the Clutch Cable.
- Tighten the outer nut on the Clutch Cable.

TO DECREASE CABLE TENSION

- Place Blade Clutch Lever in the "DISENGAGED" position.
- Loosen the outer nut on the Clutch Cable.
- Tighten the inner nut on the Clutch Cable.
- Repeat the above procedure until you have the correct tension.

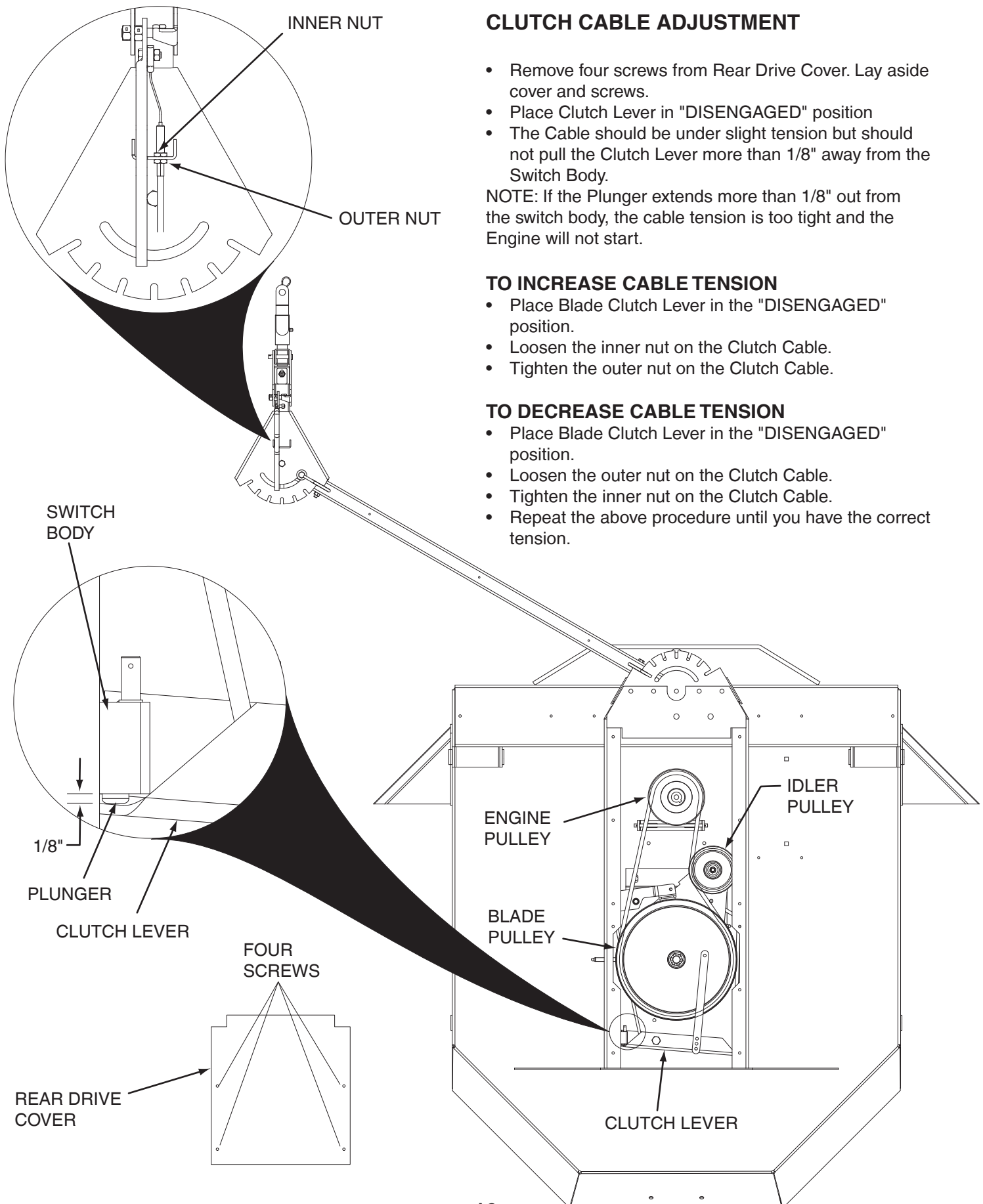

CUSTOMER RESPONSIBILITIES

V-BELT REPLACEMENT

- V-belt must be replaced if it becomes stretched to the point that it can no longer be adjusted, or if it becomes frayed or otherwise can not function properly.
- Move Blade Clutch Lever to the "DISENGAGED" position.



CAUTION:
DISCONNECT SPARK PLUG WIRE

REMOVING OLD V-BELT

- Remove Rear Drive Cover.
- Remove Front Drive Cover.
- Remove Hair Pin and Clevis Pin from Clutch Cable.
- Loosen two Rear Belt Guides and pivot them away from Blade Pulley.
- Remove V-belt from around Blade Pulley.
- Remove one small Hair Pin from Belt Keeper Rod and slide Belt Keeper Rod to the side.
- Pull V-belt down from around Engine Pulley and remove V-belt from Mower.

INSTALLING NEW V-BELT

- Feed new V-belt between the two belt guides at the Engine Pulley.
- Place V-belt up and around the Engine Pulley. Check to make sure the V-belt is seated properly in the groove of the Engine Pulley.
- Place V-belt along inside of Idler Pulley.
- Wrap V-belt down around Blade Pulley, placing Belt inside of Rear Belt Guides.
- Reinstall V-belt Keeper Rod and secure with Small Hair Pin. Check to make sure V-belt is over top of Keeper Rod.
- Reposition and retighten two Rear Belt Guides at the rear of the Blade Pulley. Leave approximately 1/16" between Guides and Pulley.
- Reinstall Clevis Pin and Hair Pin into Clutch Cable.
- Reinstall Front Drive Cover and Rear Drive Cover.

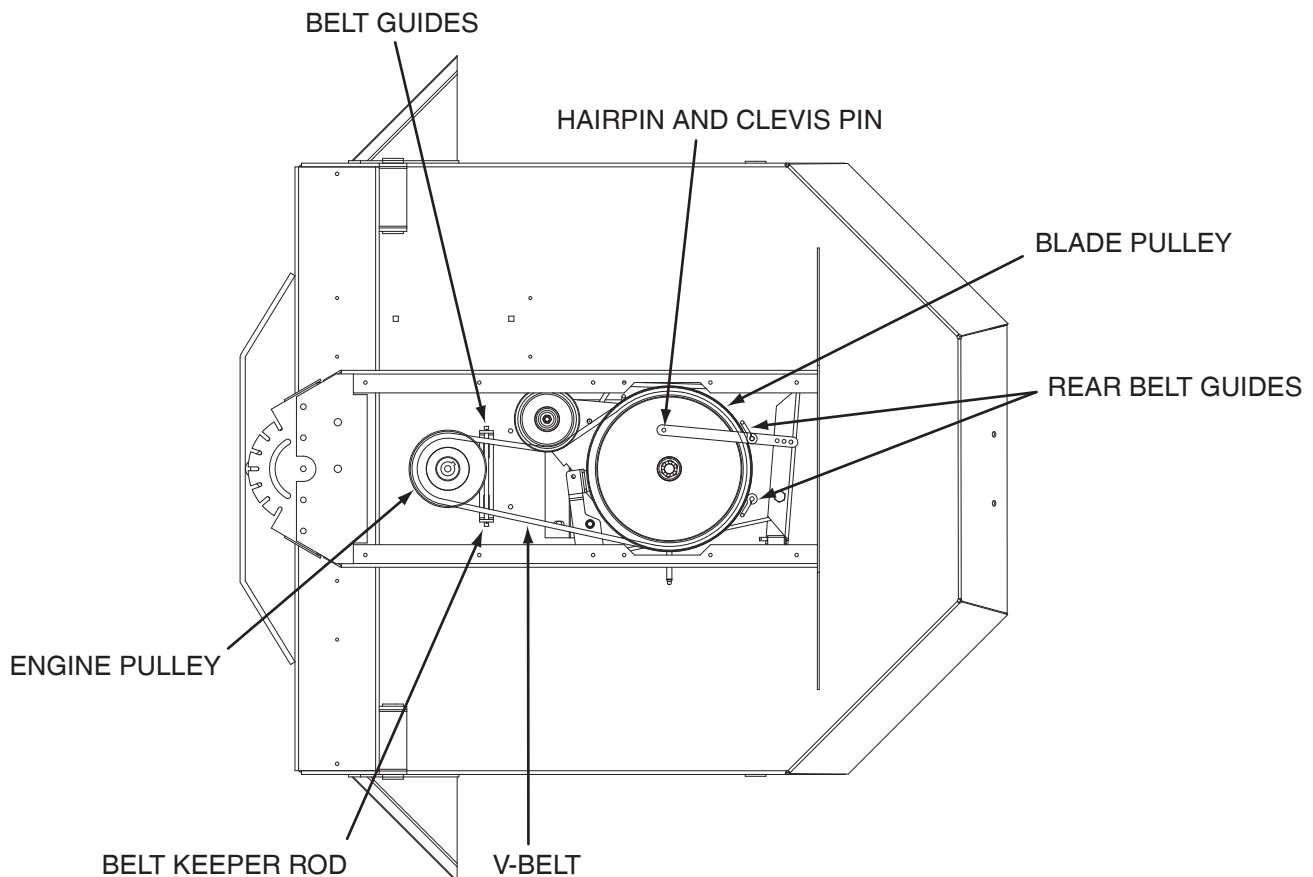

STORAGE

Immediately prepare your mower for storage at the end of the season or if the unit will not be used for 30 days or more.

MOWER

When the mower is to be stored for a period of time, clean it thoroughly, remove all dirt, grease, leaves, etc. Store in a clean dry area.

- Clean entire mower (See "CLEANING")
- Lubricate as shown in the Customer Responsibilities section of this manual.
- Be sure that all nuts, bolts, screws, and pins are securely fastened. Inspect moving parts for damage, breakage and wear. Replace if necessary.
- Touch up all rusted or chipped paint surfaces; sand lightly before painting.

CLEANING

IMPORTANT: FOR BEST PERFORMANCE, KEEP MOWER HOUSING FREE OF BUILT-UP BRUSH AND TRASH. CLEAN THE UNDERSIDE OF YOUR MOWER AFTER EACH USE.



CAUTION: Disconnect spark plug wire from spark plug and place wire where it cannot come in contact with the spark plug.

- Clean the underside of your mower by scraping to remove build-up of brush and trash.
- Keep finished surfaces and wheels free of all gasoline, oil, etc.
- We do not recommend using a garden hose to clean mower unless the electrical system, muffler, air filter, and carburetor are covered to keep water out. Water in engine can result in shortening engine life.

ENGINE

- Never use engine or carburetor cleaner products in the fuel tank or permanent damage may occur.
- Use fresh fuel every season.

NOTE: Fuel stabilizer is an acceptable alternative in minimizing the formation of fuel gum deposits during storage. Add stabilizer to gasoline in fuel tank or storage container. Always follow the mix ratio found on stabilizer container. Run engine at least 10 minutes after adding stabilizer to allow the stabilizer to reach the carburetor. Do not drain the gas tank and carburetor if using fuel stabilizer.

ENGINE OIL

Drain oil (with engine warm) and replace with clean engine oil. (See engine manual)

CYLINDER

- Remove spark plug.
- Pour one ounce (29 ml) of oil through spark plug hole into cylinder.
- Pull starter handle slowly a few times to distribute oil.
- Replace with new spark plug.

OTHER

- Do not store gasoline from one season to another.
- Replace your gasoline can if your can starts to rust. Rust and/or dirt in your gasoline will cause problems.
- If possible, store your unit indoors and cover it to give protection from dust and dirt.
- Cover your unit with a suitable protective cover that does not retain moisture. Do not use plastic. Plastic cannot breathe which allows condensation to form and will cause your unit to rust.

IMPORTANT: NEVER COVER MOWER WHILE ENGINE AND EXHAUST ARE STILL WARM.



CAUTION: Never store the mower with gasoline in the tank inside a building where fumes may reach an open flame or spark. Allow the engine to cool before storing in any enclosure.

42" ROUGH CUT TRAILMOWER - MODEL 45-03612

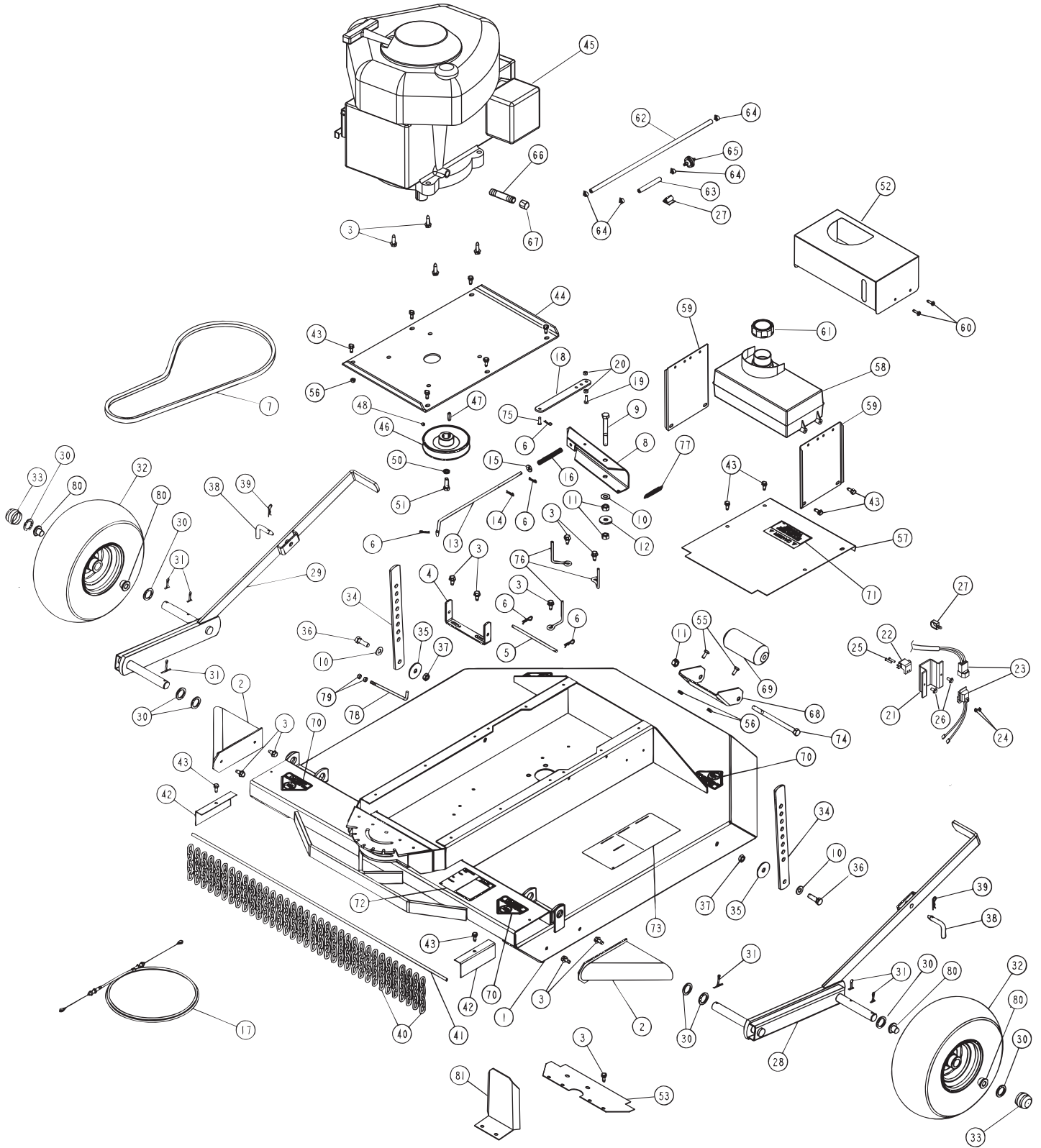

42" ROUGH CUT TRAILMOWER - MODEL 45-03612

| ITEM | PART NO. | DESCRIPTION | ITEM | PART NO. | DESCRIPTION |
|------|----------|------------------------------------|------|---------------|-------------------------------------|
| 1. | HA24255 | MOWER DECK | 41. | HA24312 | ROD CHAIN |
| 2. | HA24378 | GUARD WHEEL | 42. | HA24313 | BRACKET CHANNEL |
| 3. | HA23193 | SCREW 3/8-16 X 1-1/4 THD. FORMING | 43. | 47630 | SCREW SELF THREADING |
| 4. | HA24292 | BRACKET BELT GUIDE | 44. | 25428 | PLATE ENGINE MOUNTING |
| 5. | HA24293 | ROD BELT GUIDE | 45. | 2197020115E1* | ENGINE, 12.5 HP |
| 6. | HA3090 | PIN HAIR COTTER | 46. | HA24457 | PULLEY |
| 7. | HA24294 | V-BELT (B SEC. 60" O.C.) | 47. | HA3073 | KEY 1/4" SQ. X 1" |
| 8. | HA24295 | CHANNEL CLUTCH LEVER | 48. | HA115321 | SCREW 5/16-18 X 5/16 SOC. SET |
| 9. | 45100 | BOLT 1/2-13 X 4" HEX HEAD | 50. | 43555 | WASHER 7/16" LOCK |
| 10. | HA120396 | WASHER 1/2 FLAT | 51. | HA181668 | BOLT 7/16-20 X 1-1/4 HEX HEAD |
| 11. | 43262 | NUT 1/2-13 HEX LOCK | 52. | 25051 | COVER, GAS TANK |
| 12. | HA14232 | WASHER FLAT | 53. | 25265 | COVER, FRONT DRIVE |
| 13. | HA24296 | ROD CLUTCH LINK | 55. | 43182 | BOLT 5/16-18 X 3/4 HEX HEAD |
| 14. | 44101 | PIN, COTTER 3/32" X 3/4" | 56. | 47810 | NUT 5/16-18 HEX LOCK (NYLOCK) |
| 15. | 43081 | WASHER FLAT 5/16" STD. WRT. | 57. | 25264 | COVER, REAR DRIVE |
| 16. | HA24297 | SPRING CLUTCH | 58. | HA23732 | TANK GASOLINE |
| 17. | HA24617 | CLUTCH CABLE ASSY (Model 45-03071) | 59. | HA24317 | PLATE FUEL TANK |
| | 49165 | CLUTCH CABLE ASSY (Model 45-0361) | 60. | HA163318 | SCREW 1/4-14 X 7/8 TAPPING PAN HEAD |
| 18. | 25292 | STRAP, CLUTCH ADJUSTING | 61. | HA23733 | CAP GASOLINE TANK |
| 19. | 43661 | BOLT, 1/4-20 X 1" HEX HEAD | 62. | 48837 | HOSE FUEL TANK LONG |
| 20. | 47189 | NUT 1/4-20 HEX LOCK (NYLOCK) | 63. | HA24455 | HOSE FUEL TANK SHORT |
| 21. | 25262 | BRACKET INTERLOCK MOUNTING | 64. | HA23792 | CLAMP FUEL LINE |
| 22. | HA23199 | SWITCH INTERLOCK | 65. | HA23791 | FILTER FUEL LINE |
| 23. | 64904 | MODULE ASSY WITH WIRES | 66. | 48095 | PIPE |
| 24. | 712-0121 | NUT #10-24 HEX | 67. | 48096 | CAP |
| 25. | 47078 | SCREW #10-24 X 3/4" | 68. | HA24310 | BRACKET ROLLER |
| 26. | 48840 | SCREW 1/4-20 WASHER HEAD | 69. | HA12138 | ROLLER MOWER |
| 27. | 48298 | CLIP, CORD | 70. | HA12315 | DECAL DANGER (HAND) |
| 28. | HA24300 | WHEEL MOUNTING BRACKET L.H. | 71. | HA12314 | DECAL DANGER |
| 29. | HA24301 | WHEEL MOUNTING BRACKET R.H. | 72. | HA24365 | DECAL OPERATION/CAUTION |
| 30. | HA4143 | WASHER FLAT | 73. | HA24366 | DECAL HEIGHT ADJUSTMENT |
| 31. | HA137258 | PIN COTTER 3/16" X 1-3/4" | 74. | HA126145 | BOLT 1/2-13 X 7" HEX HEAD |
| 32. | 42159 | TIRE | 75. | 43982 | PIN, CLEVIS 1/4" X 5/8" |
| 33. | HA23229 | CAP HUB | 76. | HA22981 | BELT GUIDE |
| 34. | HA24309 | STRAP ADJUSTING | 77. | HA24298 | SPRING RETURN |
| 35. | HA6979 | WASHER FLAT | 78. | 49156 | ROD, CABLE GUIDE |
| 36. | 43020 | BOLT 1/2-13 X 1-1/2 HEX HEAD | 79. | 43013 | NUT 1/4-20 HEX |
| 37. | 43019 | NUT 1/2-13 HEX JAM | 80. | 44488 | WHEEL BEARING |
| 38. | HA23220 | PIN LOCATING | 81. | 25293 | WIRE GUARD PLATE |
| 39. | 47134 | PIN HAIR COTTER .08" X 1.58" | | | |
| 40. | HA24311 | CHAIN DEFLECTOR | | | |

* Order engine repair parts from your nearest Briggs & Stratton dealer.

42" ROUGH CUT TRAILMOWER - MODEL 45-03612

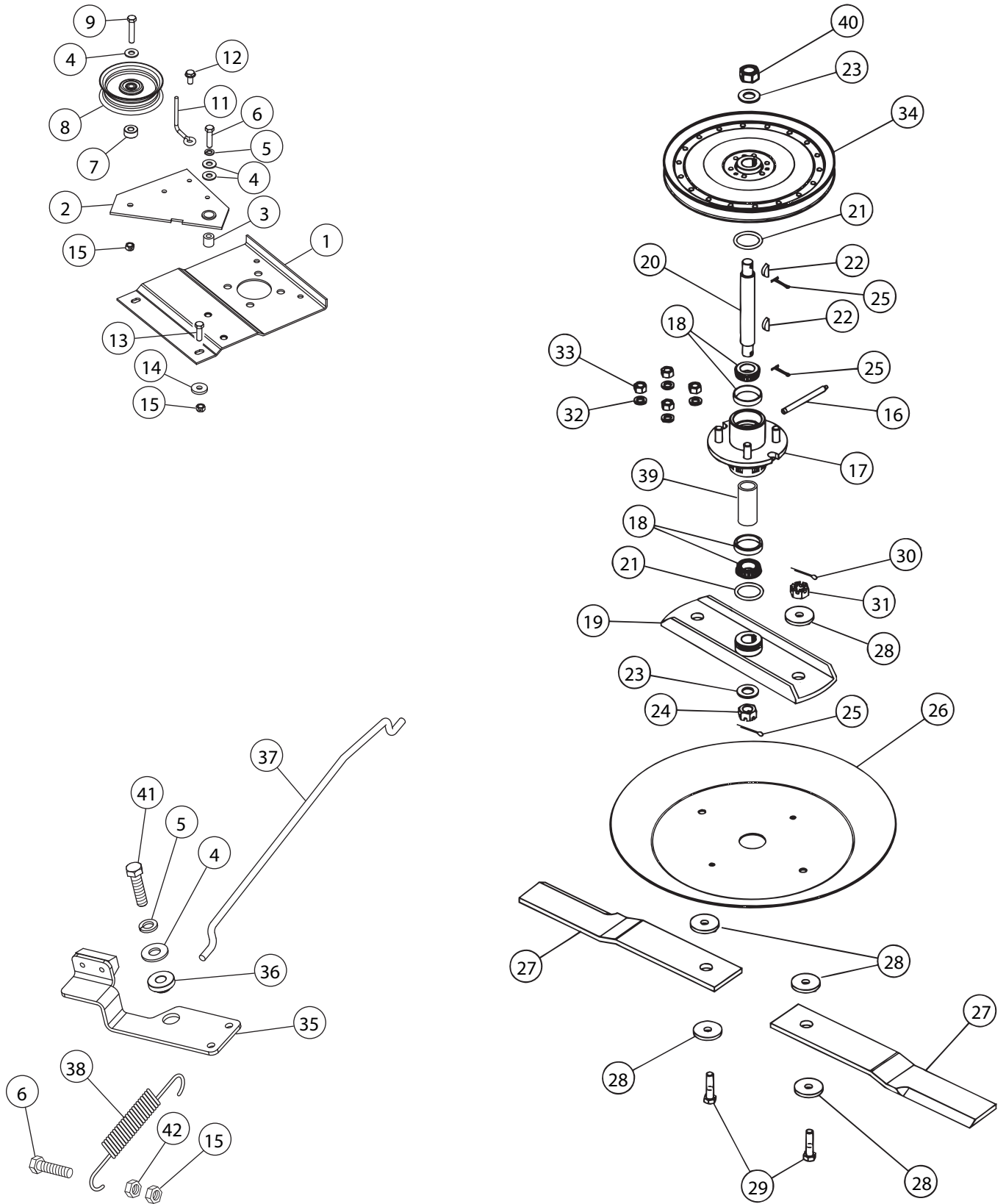

42" ROUGH CUT TRAILMOWER - MODEL 45-03612

| ITEM | PART NO. | DESCRIPTION |
|------|----------|--|
| 1. | 64906 | IDLER MOUNTING BRACKET |
| 2. | 64899 | IDLER ARM |
| 3. | 24472 | BUSHING |
| 4. | 43070 | WASHER FLAT |
| 5. | 43003 | WASHER 3/8" LOCK |
| 6. | 43062 | BOLT 3/8-16 X 1-1/2" HEX HEAD |
| 7. | 49148 | SPACER |
| 8. | HA21341 | IDLER PULLEY (FLAT) |
| 9. | 43432 | BOLT 3/8-16 X 2-1/2" HEX HEAD |
| 10. | 43082 | NUT 3/8-16 HEX LOCK |
| 11. | HA22981 | GUIDE BELT |
| 12. | HA22224 | SCREW 3/8-16 X 3/4 SELF TAPPING |
| 13. | 43087 | BOLT 3/8-16 X 1-1/4" HEX HEAD |
| 14. | HA15200 | WASHER FLAT |
| 15. | HA21362 | NUT 3/8-16 NYLOCK |
| 16. | HA24367 | GREASE FITTING |
| 17. | HA24278 | HUB (WITH STUDS) |
| 18. | HA24280 | BEARING |
| 19. | 64913 | HUB BLADE |
| 20. | 49149 | SHAFT SPINDLE |
| 21. | HA24282 | SEAL O-RING |
| 22. | HA3073 | KEY 1/4" SQ X 1" |
| 23. | HA456151 | WASHER 13/16 X 1-1/2 X .134 FLAT |
| 24. | HA427639 | NUT 3/4-16 SLOTTED HEX |
| 25. | 43010 | PIN 1/8" X 1" COTTER |
| 26. | HA24624 | DISC BLADE MOUNTING |
| 27. | HA24288 | BLADE |
| 28. | HA24625 | WASHER - FLAT |
| 29. | HA24592 | BOLT - 7/8-9 X 2-1/4" HEX BOLT |
| 30. | HA137258 | PIN 3/16 X 1-3/4 COTTER |
| 31. | HA24593 | NUT 7/8-9 SLOTTED HEX |
| 32. | 43353 | WASHER 1/2 MED. LOCK |
| 33. | HA120371 | NUT 1/2-20 HEX |
| 34. | 65102 | PULLEY, SPINDLE |
| 35. | 64902 | BRAKE |
| 36. | 49155 | TRUNNION |
| 37. | 49160 | BRAKE ROD |
| 38. | HA20186 | SPRING |
| 39. | 49624 | SPACER, BEARING |
| 40. | 49674 | NUT, 3/4-16 NYLOCK |
| 41. | 49681 | BOLT, HEX 3/8-16 X 1" HEX HEAD (SCOTCH GRIP) |
| 42. | 43015 | NUT, HEX 3/8-16 |

42" ROUGH CUT TRAILMOWER - MODEL 45-03612

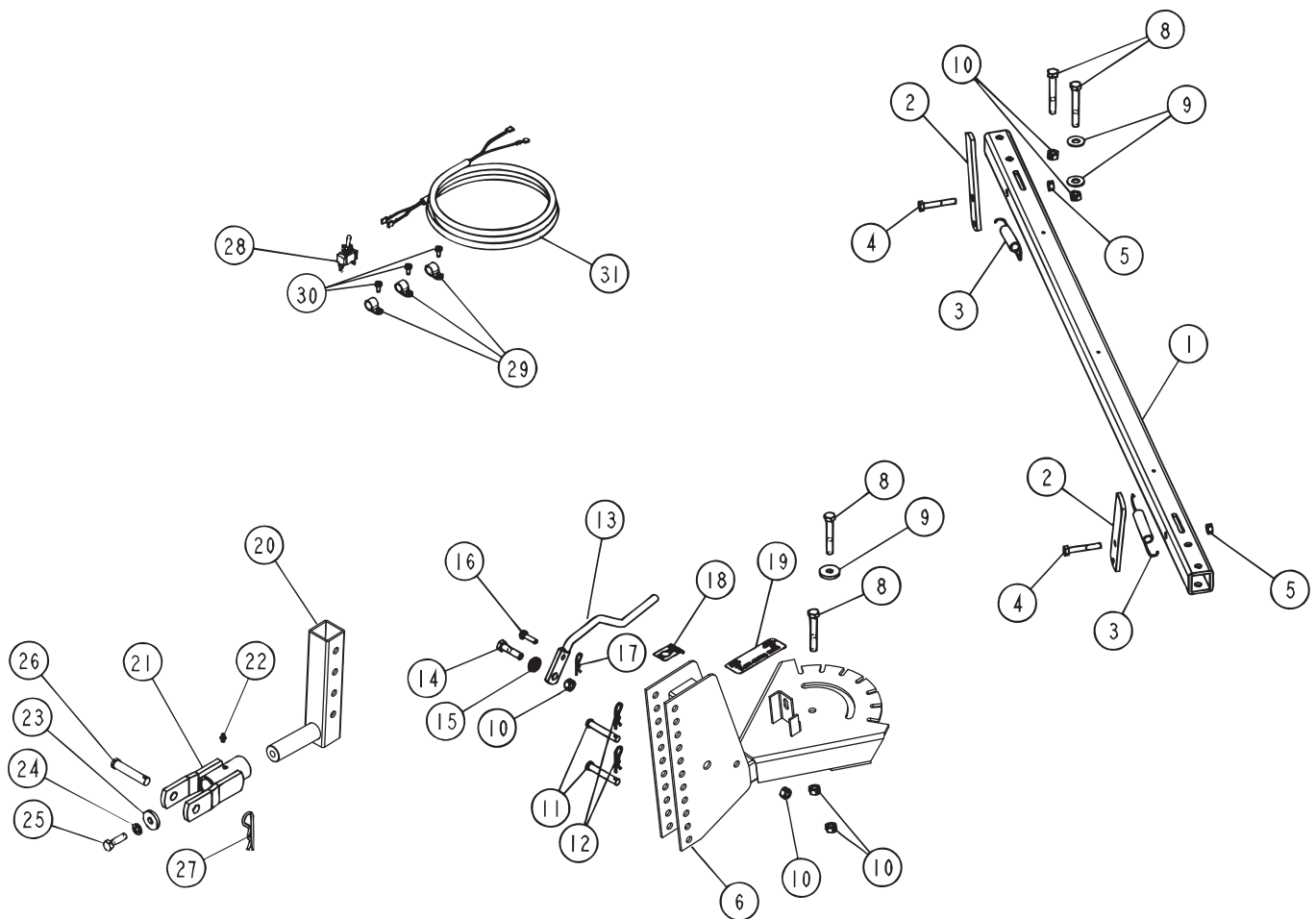

| ITEM | PART NO. | DESCRIPTION | ITEM | PART NO. | DESCRIPTION |
|------|----------|-------------------------------|------|-----------|---------------------------------|
| 1. | 25273 | TUBE DRAWBAR (MODEL 45-0361) | 17. | HA3090 | PIN, HAIR COTTER .08 X 1-1/8 |
| | HA24321 | TUBE DRAWBAR (MODEL 45-03071) | 18. | HA23262 | DECAL ENGINE SHUT-OFF |
| 2. | HA24441 | STRAP HITCH | 19. | HA23265 | DECAL CLUTCH LEVER |
| 3. | HA20186 | SPRING EXTENSION | 20. | 64910 | BRACKET DRAWBAR ADJUSTMENT |
| 4. | 44180 | BOLT 5/16-18 X 2" HEX HEAD | 21. | HA24326 | DRAWBAR SWIVEL |
| 5. | 47810 | NUT 5/16-18 HEX LOCK | 22. | HA5074 | FITTING GREASE |
| 6. | 64909 | HITCH ASSEMBLY | 23. | HA15200 | WASHER |
| 8. | 43509 | BOLT 3/8-16 X 2-3/4 HEX HEAD | 24. | 43003 | WASHER 3/8 LOCK |
| 9. | 43070 | WASHER 3/8 FLAT | 25. | 43087 | BOLT 3/8-16 X 1-1/4 HEX HEAD |
| 10. | 43082 | NUT 3/8-16 HEX LOCK | 26. | HA24330 | PIN CLEVIS |
| 11. | HA23636 | PIN CLEVIS | 27. | HA3341 | PIN HAIR COTTER, 5/32" |
| 12. | 47134 | PIN HAIR COTTER .08 X 1.58 | 28. | HA22759 | SWITCH ON/OFF |
| 13. | 49157 | LEVER CLUTCH | 29. | HA23761 | CLIP HOSE 3/8" |
| 14. | 43062 | BOLT 3/8-16 X 1-1/2 HEX HEAD | 30. | HA9411666 | SCREW #10-16 X 1/2 SELF TAPPING |
| 15. | HA19445 | SPRING COMPRESSION | 31. | 49164 | WIRE HARNESS (MODEL 45-0361) |
| 16. | 43982 | PIN, CLEVIS 1/4 X 5/8 | | HA24353 | WIRE HARNESS (MODEL 45-03071) |

WIRING DIAGRAM

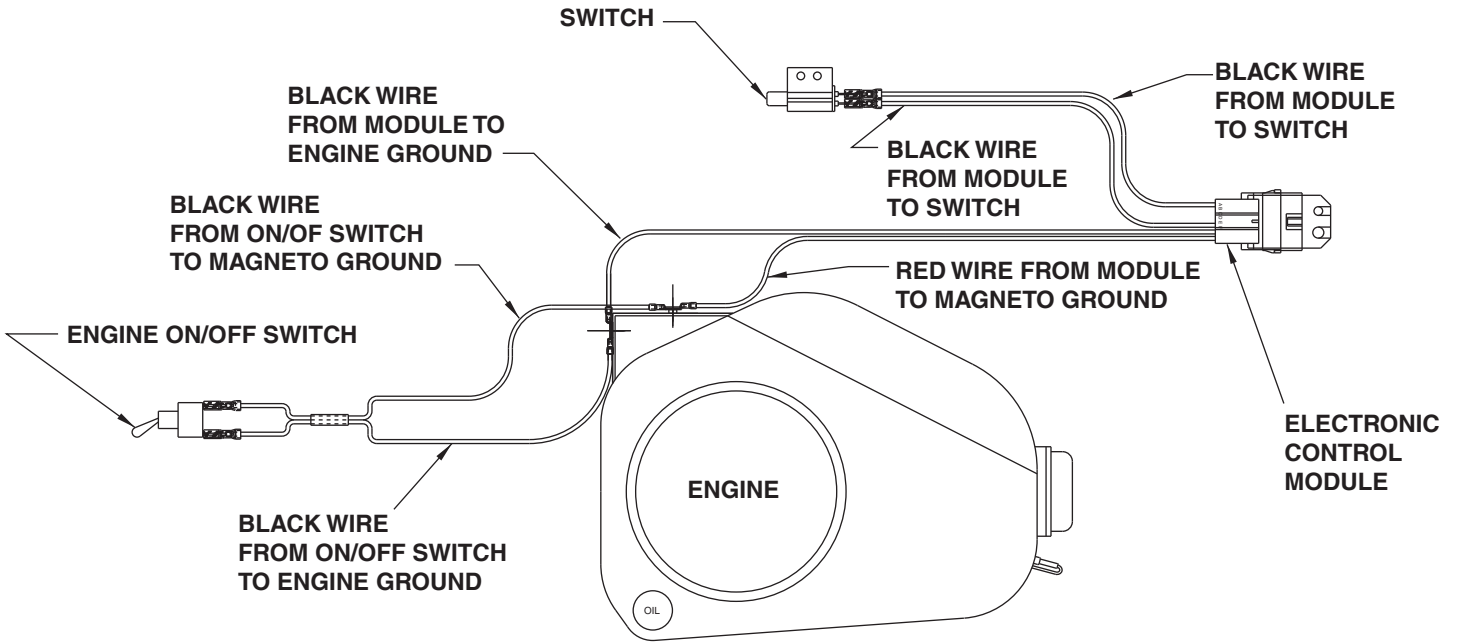

SpeedEPart *the fastest way to purchase parts* www.speedepart.com

REPAIR PARTS

Agri-Fab, Inc.
809 South Hamilton
Sullivan, IL. 61951
217-728-8388
www.agri-fab.com