

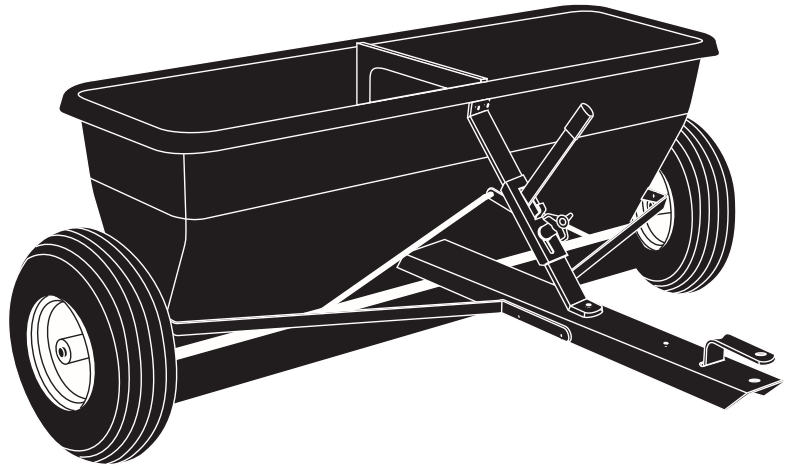

## OWNERS MANUAL

**Model No.  
45-02882**



## 175 LB. POLY PRO DROP SPREADER

**CAUTION:**  
Read Rules for  
Safe Operation  
and Instructions  
Carefully

- Safety
- Assembly
- Operation
- Maintenance
- Parts

**SpeedEPart** *the fastest way to purchase parts* [www.speedepart.com](http://www.speedepart.com)

# RULES FOR SAFE OPERATIONS

Any power equipment can cause injury if operated improperly or if the user does not understand how to operate the equipment. Exercise caution at all times, when using power equipment.

- Read this owner's manual before attempting to assemble or operate the spreader.
- Read the towing vehicle owner's manual and know how to operate the tractor before using the spreader attachment.
- Do not allow anyone to ride on or sit on spreader.
- Never allow children to operate the tractor or spreader attachment.
- Do not allow adults to operate the tractor or spreader without proper instructions.
- Read the chemical label for instructions and cautions for handling and applying chemicals.
- Wear eye and hand protection when handling and using lawn chemicals.
- Always begin with the transmission in first (low) gear and gradually increase speed as conditions permit. Maximum towing speed - 6 M.P.H.
- Do not drive too close to a creek or ditch and be alert for holes and other hazards which could cause you to lose control of the tractor and spreader.
- Before operating the vehicle on any grade (hill) refer to the safety rules in the vehicle owner's manual concerning safe operation on slopes. **Stay off steep slopes!**
- Follow maintenance and lubrication instructions as outlined in this manual.

 Look for this symbol to point out important safety precautions. It means – **Attention!! Become alert!!** Your safety is involved.

## CARTON CONTENTS

- |                       |                      |
|-----------------------|----------------------|
| 1. Hopper Assembly    | 5. Flow Control Rod  |
| 2. Flow Control Gauge | 6. Tongue Braces (2) |
| 3. Hopper Brace       | 7. Tongue            |
| 4. Flow Control Arm   | 8. Hitch Bracket     |

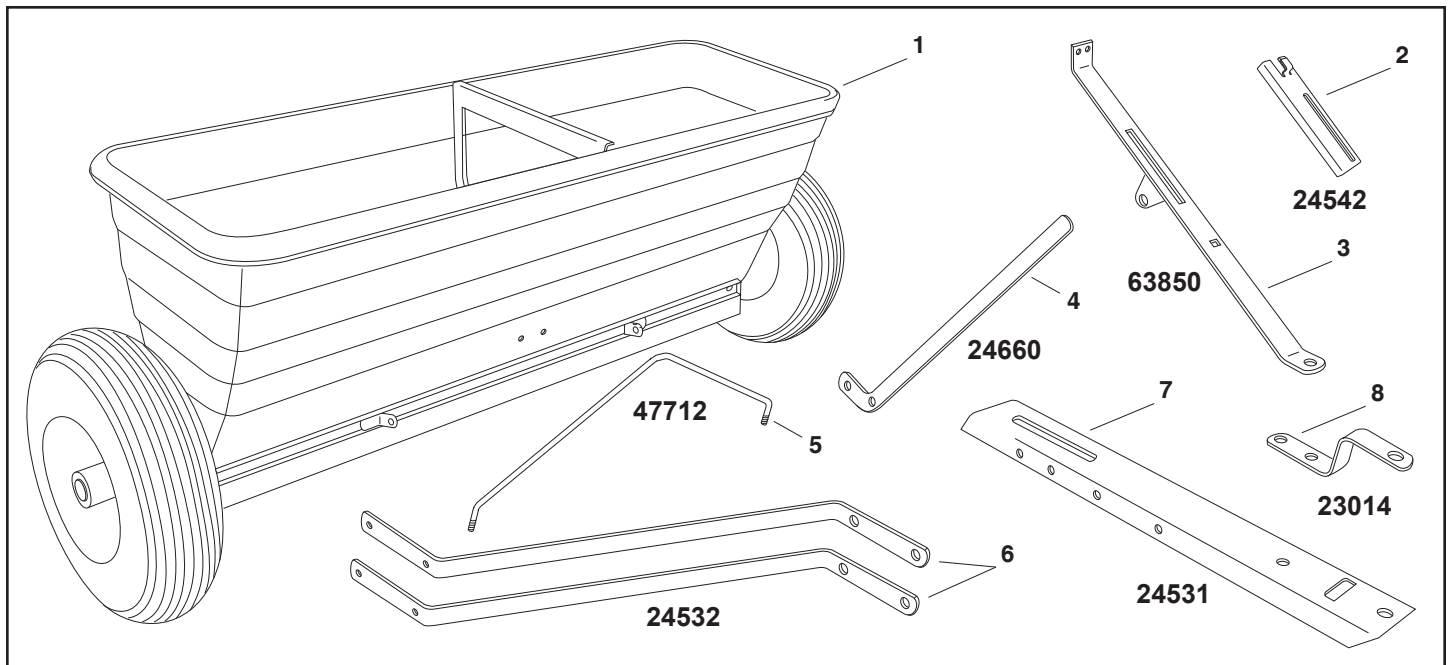

**SHOWN FULL SIZE**

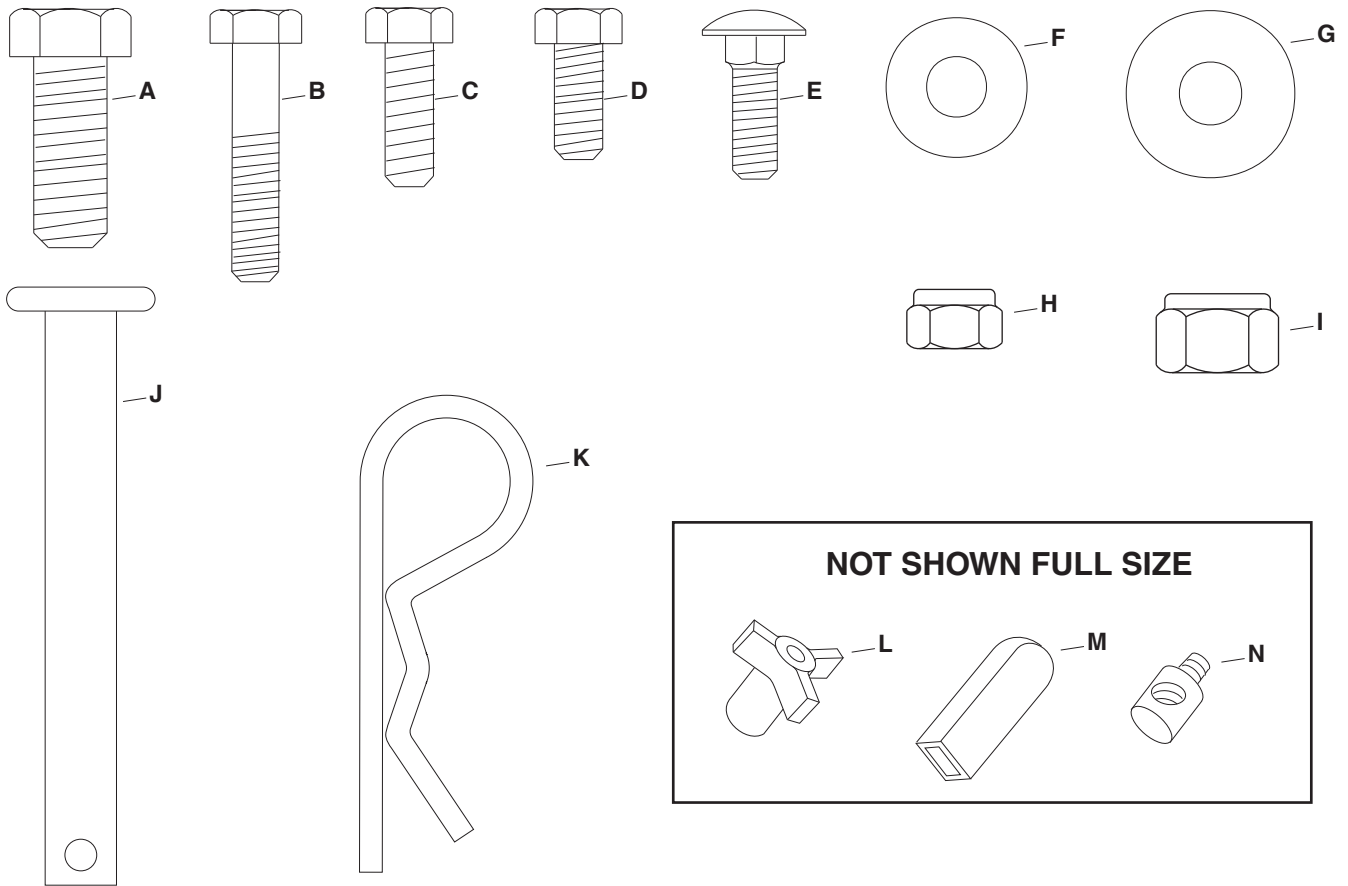

**NOT SHOWN FULL SIZE**

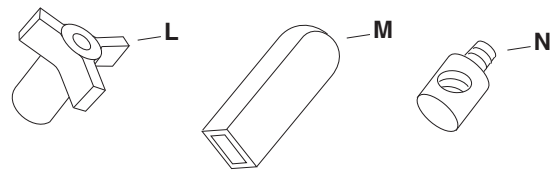

**HARDWARE CHART**

REF.	QTY.	PART NO.	DESCRIPTION	REF.	QTY.	PART NO.	DESCRIPTION
A	1	43001	Hex Bolt, 3/8" x 1"	H	16	47189	Nylock Nut, 1/4"
B	1	1509-90	Hex Bolt, 1/4" x 1-1/4"	I	1	HA21362	Nylock Nut, 3/8"
C	2	43012	Hex Bolt, 1/4" x 3/4"	J	1	47623	Hitch Pin
D	10	43866	Hex Bolt, 1/4" x 5/8"	K	1	43343	Hair Cotter Pin, 1/8"
E	1	44950	Carriage Bolt, 1/4" x 3/4"	L	1	43849	Plastic Knob
F	4	43088	Flat Washer, 1/4"	M	1	43848	Plastic Grip
G	3	1543-69	Nylon Washer	N	2	47711	Ferrule

# ASSEMBLY

## TOOLS REQUIRED FOR ASSEMBLY

- (2) 7/16" Wrenches
- (2) 9/16" Wrenches

1. Remove the hardware pack and all individual parts from the carton and lay out as shown on page 2 and 3.
2. Assemble the tongue to the hopper as shown in figure 1 using two 1/4" x 5/8" hex bolts and 1/4" nylock nuts. **Do not tighten yet.**

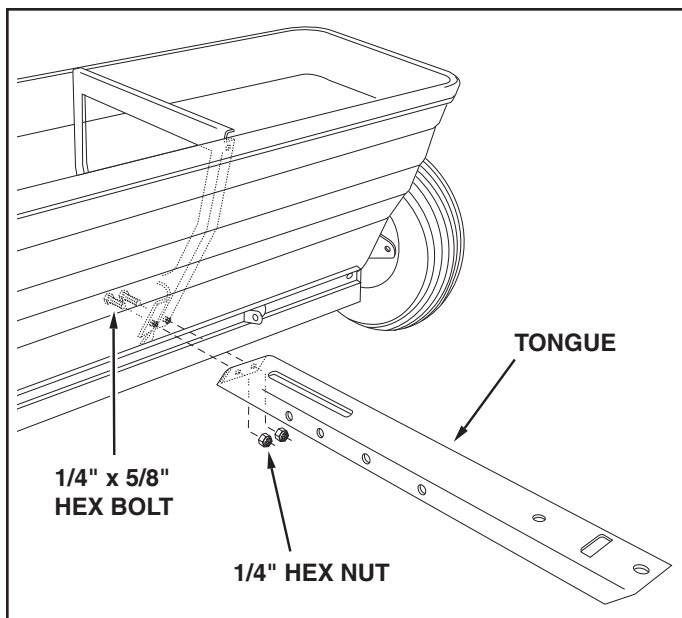

FIGURE 1

3. Assemble the plastic grip onto the end of the flow control arm as shown in figure 2.
4. Insert the flow control arm through the slot in the hopper brace. Place a nylon washer on each side of the arm and attach it to the brace's welded bracket using a 1/4" x 1-1/4" hex bolt, a 1/4" flat washer and two 1/4" nylock nuts as shown in figure 2. **Tighten** the first nylock nut until there is noticeable resistance when moving the flow control arm, then **tighten** the second nylock nut.
5. Place the flow control rod through the hole at the end of the flow control arm. Assemble the two ferrules onto the threaded ends of the rod so that approximately 1/2" of the rod extends through the ferrules. See figure 2.

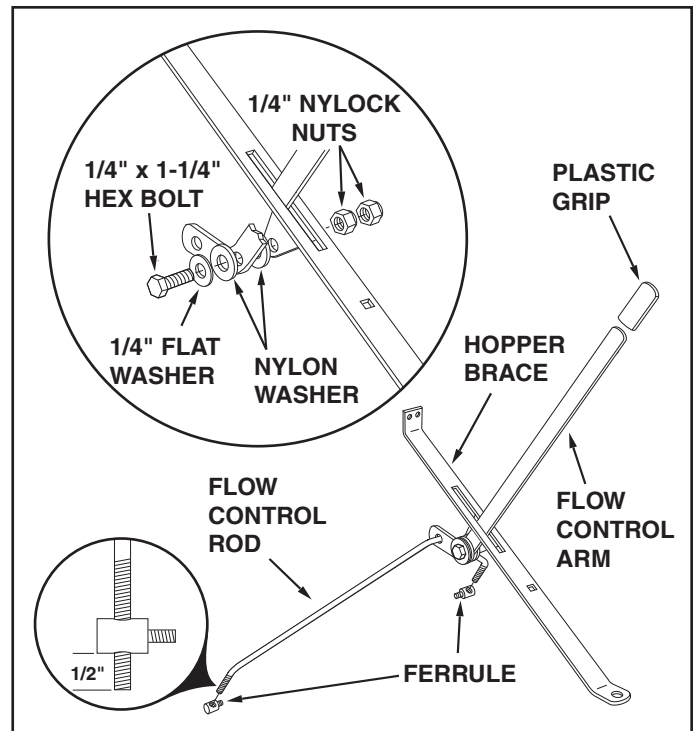

FIGURE 2

6. Attach the hopper brace to the hopper using two 1/4" x 5/8" hex bolts, one 1/4" flat washer and two 1/4" nylock nuts. **Do not tighten yet.** See figure 3.
7. Place the end of the hitch bracket (two holes) down through the slot in the tongue. Attach the hopper brace to the top of the tongue and the hitch bracket to the bottom using one 3/8" x 1" hex bolt and 3/8" nylock nut. **Tighten all bolts** assembled so far. See figure 3.

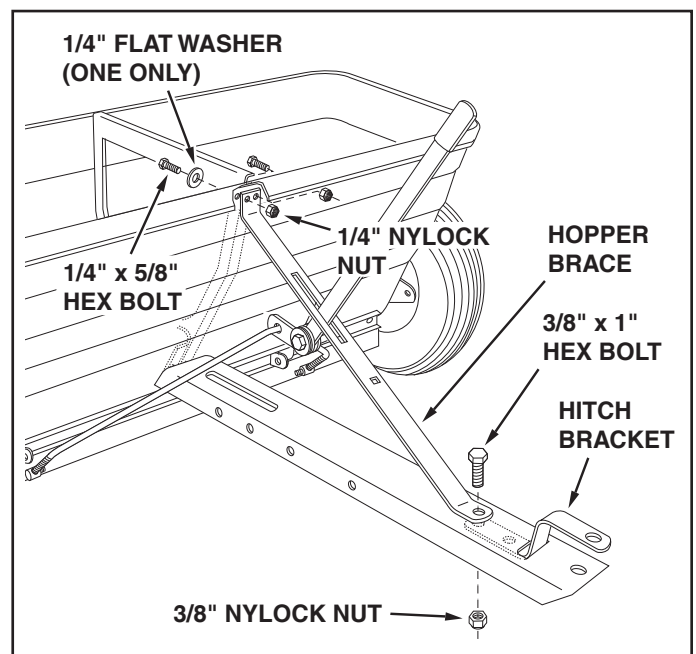
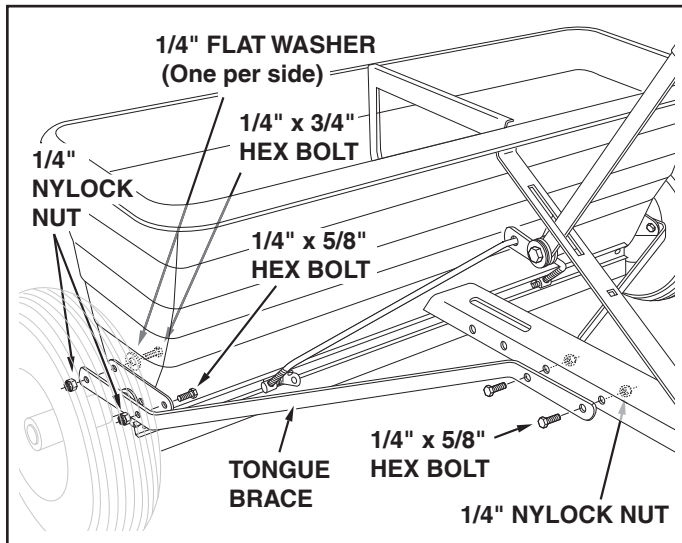

FIGURE 3

8. Assemble one end of a tongue brace to the side of the tongue using two 1/4" x 5/8" hex bolts and 1/4" nylock nuts. **Do not tighten yet.** See figure 4.
9. Assemble the other end of the tongue brace to the triangular plate on the end of the spreader. Use a 1/4" x 5/8" hex bolt and 1/4" nylock nut in the front hole of the plate. Use a 1/4" x 3/4" hex bolt, 1/4" flat washer and 1/4" nylock nut in the rear hole, with the bolt and washer assembled on the inside of the hopper as shown in figure 4. **Do not tighten yet.**
10. Repeat steps 8 and 9 to attach the second tongue brace to the other end of the spreader and then **tighten** all loose bolts.



**FIGURE 4**

11. With 1/2" of the control rod extending through both ferrules, insert them into the brackets that are riveted to the flow plates. Assemble 1/4" nylock nuts onto the ferrules, making them only **finger tight** at this time. See figure 5.

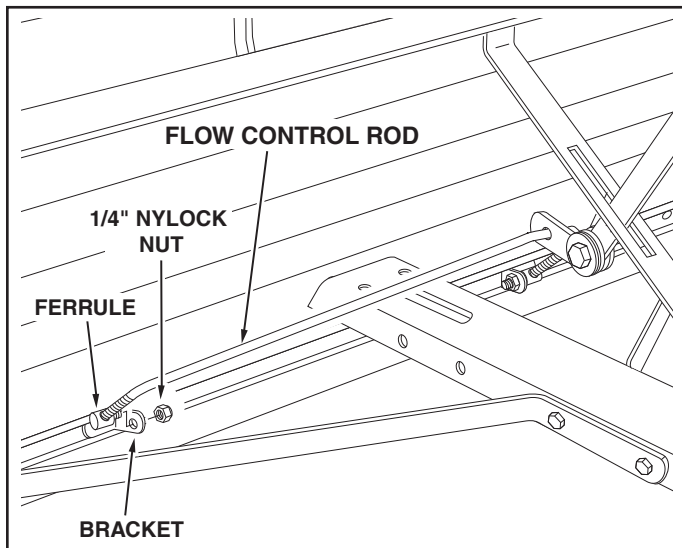

**FIGURE 5**

12. Assemble the flow control gauge to the hopper brace using the 1/4" x 3/4" carriage bolt, a nylon washer and the plastic knob. See figure 6.
13. Install the hitch pin and the 1/8" hair cotter pin in the spreader hitch bracket and tongue. See figure 6.

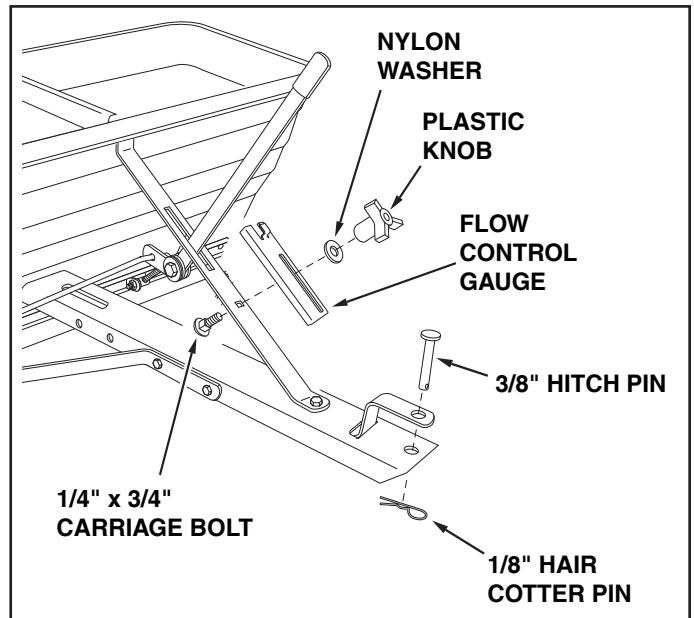

**FIGURE 6**

14. Adjust for correct opening of hopper flow plates:
  - a. Set the flow control gauge at the highest setting.
  - b. Move the flow control arm back against the gauge.
  - c. Adjust both ferrules so that the slots in the bottom of the hopper are completely open and the flow plates are aligned with the edges of the slots at both ends of the hopper.
  - d. Move the flow control arm to the off position.
  - e. Set the flow control gauge at the "0" setting.
  - f. Move the flow control arm back against the gauge and check if the slots in the bottom of the hopper are now covered by the flow plates. If needed, repeat the adjusting instructions.
  - g. **Tighten** the nuts on both ferrules and then loosen the nuts 1/4 turn.
15. Check for proper tension on the hopper flow plates:
  - a. Move the flow control gauge to the highest setting.
  - b. Move the flow control arm to a middle setting.
  - c. Press directly against the flow plates at the bottom of the hopper. It should require considerable effort to move the flow plates.
  - d. If they move too easily, tighten the nuts on the flow control arm to increase the resistance.

# OPERATION

## HOW TO USE YOUR SPREADER

1. Refer to the instruction label on the material package and to the instruction decal on your spreader to help determine the proper spreader setting and application rate. Also see the Setting Chart on this page which contains safe, beginning settings for fertilizer.
2. Loosen the plastic knob and adjust the flow control gauge to the recommended setting. Retighten the knob. See figure 7.
3. Determine the approximate square footage of the area to be covered and estimate the amount of fertilizer or seed required.
4. Move the spreader to the area where application is to begin.
5. Making sure the flow control arm is in the "OFF" position, fill the hopper, breaking up any lumps.
6. Start the spreader in motion and then pull the flow control arm forward to the "ON" position as you travel across your lawn. The recommended towing speed is 3 m.p.h.

**IMPORTANT:** Always place flow control arm in the "OFF" position to prevent excess fertilizer from being released when filling the spreader and when stopping or turning.

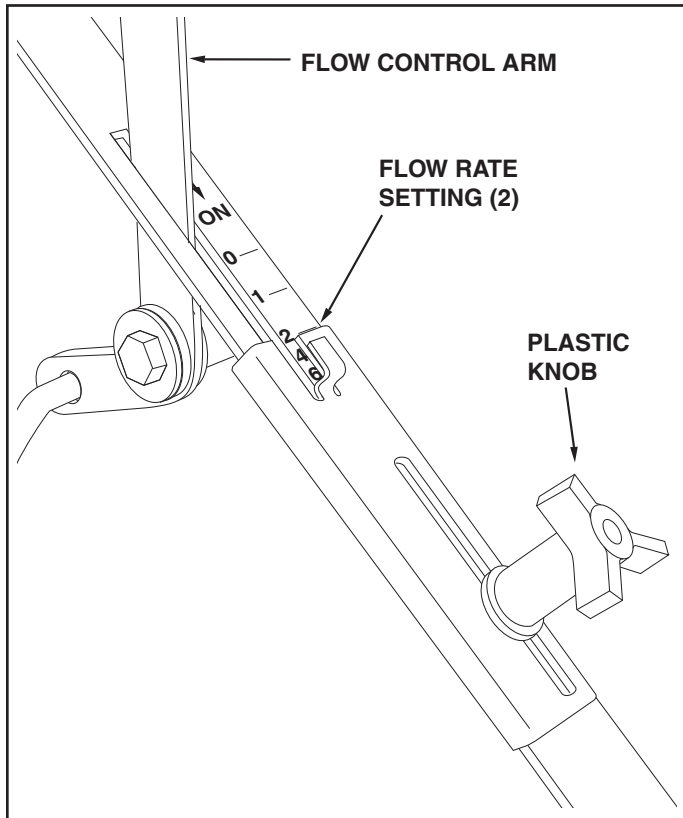

FIGURE 7

# SETTING CHART

MATERIAL	TYPE	FLOW SETTING AT 3 M.P.H.
Fertilizer	Granular / Pellet	0-1 / 0-2
Grass Seed	Fine / Coarse	5-6 / 7-8

## SETTINGS ARE FOR A SPEED OF 3 MPH.

3 M.P.H. is equivalent to traveling 100 feet in 23 seconds.



**CAUTION:** Do not over-apply fertilizer. Avoid turf damage by starting at a low flow setting until you determine best setting.

## APPLICATION TIPS

1. To help prevent clogging when using **granular** material, avoid towing the spreader with the flow plate closed. A closed flow plate could cause the rotating agitator to work the material into powder, compacting it at the bottom of the hopper.
2. Reduce the flow setting for speeds slower than 3 M.P.H. Increase it for speeds higher than 3 M.P.H.
3. To avoid misses or striping, overlap the previous wheel tracks by approximately 4" - 5". The spread width of the spreader is approximately 40".
4. For easiest application, first apply material across both ends of the area. Two or three passes on each end are sufficient. Then apply material back and forth as shown. Use the end areas for turning around, shutting off the spreader as you enter the end areas and turning the spreader on again as you leave the end areas for your next pass. See figure 8.
5. If lawn is odd shaped, spread a border around the edges and then spread between the border.

**NOTE:** Be careful when using the spreader around ornamental plants because weed control chemicals can damage these plants.

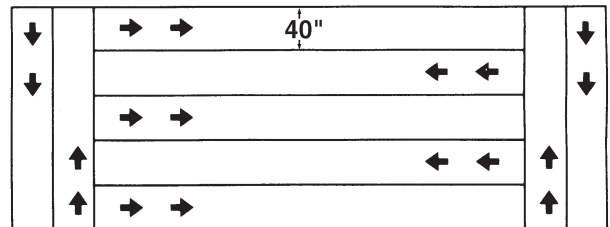

FIGURE 8

# MAINTENANCE

1. Always empty spreader after each use, storing leftover material in it's original bag.
2. Wash the spreader and dry thoroughly after each use.
3. Apply a few drops of oil to all moving parts.
4. Check all nuts and bolts for tightness before each use.
5. Keep tires inflated to 12 - 14 lbs.



# REPAIR PARTS FOR 175 LB. DROP SPREADER MODEL 45-02882

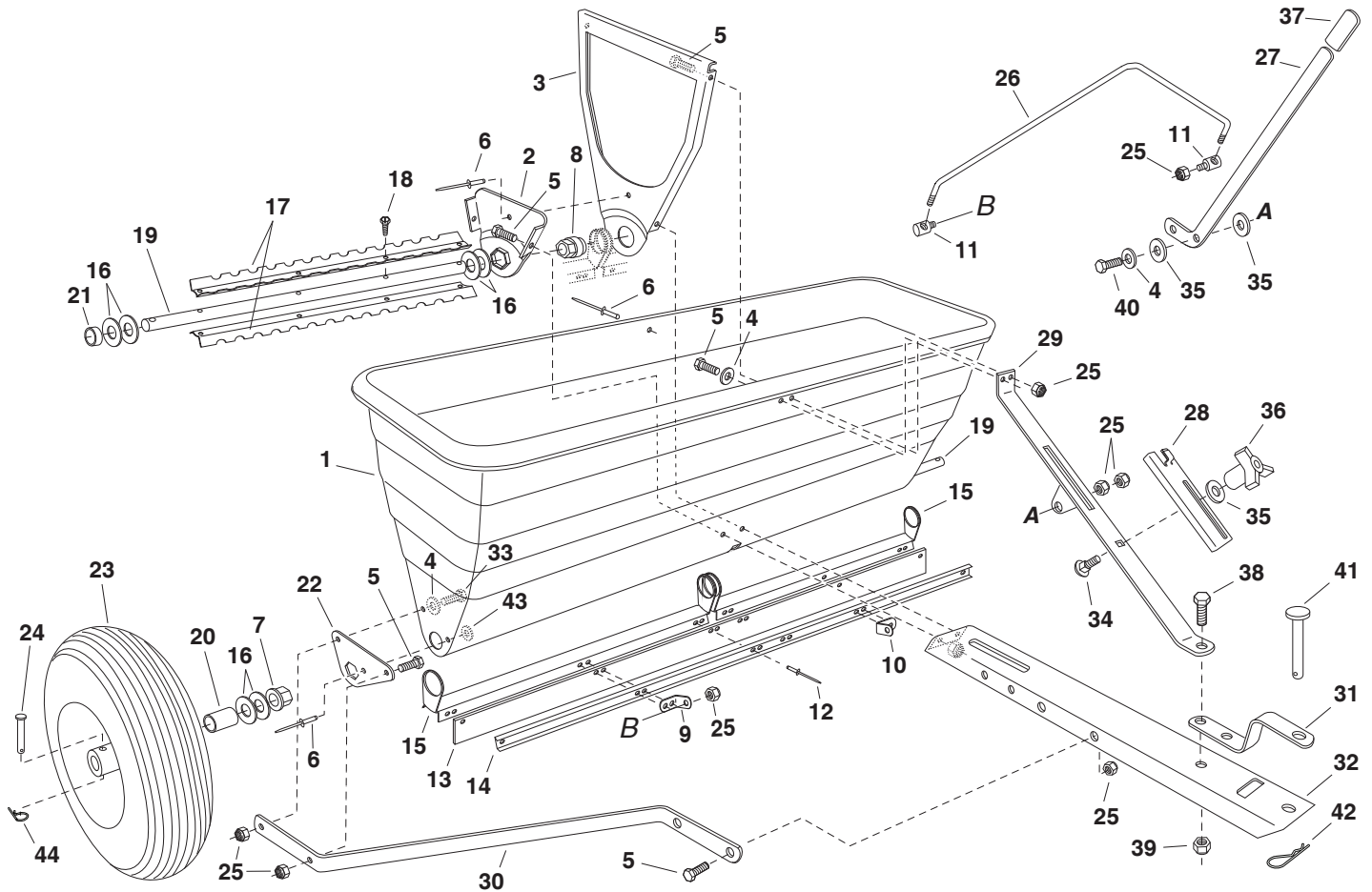

REF. NO.	PART NO.	QTY.	DESCRIPTION	REF. NO.	PART NO.	QTY.	DESCRIPTION
1	47451	1	Hopper	24	46867	2	Clevis Pin, 1/4" x 1-3/4"
2	24536	1	Hopper Center Plate (Small)	25	47189	16	Nylock Nut, 1/4-20 Thd.
3	24535	1	Hopper Center Plate (Large)	26	47712	1	Rod, Flow Control
4	43088	4	Washer, 1/4"	27	24660	1	Arm, Flow Control
5	43866	10	Bolt, Hex 1/4-20 x 5/8"	28	24542	1	Gauge, Flow Control
6	48373	6	Pop Rivet	29	63850	1	Brace Assembly, Hopper
7	47615	2	Bearing, Flange	30	24532	2	Brace, Tongue
8	47484	1	Bearing, Hex Flange	31	23014	1	Hitch Bracket
9	24538	1	Bracket, Feed Plate (RH)	32	24531	1	Tongue
10	24539	1	Bracket, Feed Plate (LH)	33	43012	2	Bolt, Hex 1/4-20 x 3/4"
11	47711	2	Ferrule	34	44950	1	Bolt, Carriage 1/4-20 x 3/4" Lg.
12	728-3001	10	Pop Rivet	35	1543-69	3	Washer, Nylon
13	47459	1	Skirt, 48"	36	43849	1	Knob, Plastic 1/4-20 Thd.
14	47508	1	Retainer, Skirt	37	43848	1	Grip, Plastic
15	24537	2	Flow Plate	38	43001	1	Bolt, Hex 3/8-16 x 1" Lg.
16	43009	10	Washer	39	HA21362	1	Nut, Hex Lock 3/8-16 Thd.
17	47259	4	Agitator Blade	40	1509-90	1	Bolt, Hex 1/4-20 x 1-1/4" Lg.
18	47978	16	Screw, #8-32 x 1/4" Lg.	41	47623	1	Hitch Pin, 3/8"
19	24540	2	Axle	42	43343	1	Hair Cotter Pin, 1/8"
20	48665	2	Spacer, Tube 1" OD x 1.65" Lg.	43	736-0142	2	Washer 1/4" x 5/8"
21	47458	2	Spacer, 1.25" OD x .330" Lg.	44	43055	2	Hair Cotter Pin, 3/32"
22	24534	2	Plate, Bearing		40944	1	Owners Manual
23	40939	2	Wheel				

***SpeedPart*** *the fastest way to purchase parts* [www.speedepart.com](http://www.speedepart.com)

**REPAIR PARTS**  
809 South Hamilton  
Sullivan, IL. 61951  
217-728-8388  
[www.agri-fab.com](http://www.agri-fab.com)